

JVC

SERVICE MANUAL

DVD DIGITAL THEATER SYSTEM

TH-A9

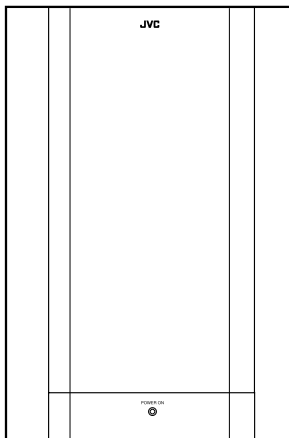

SP-PWA9

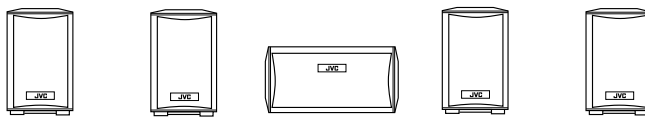

SP-XSA9

SP-XCA9

SP-XSA9

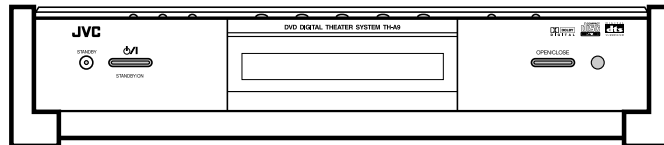

XV-THA9

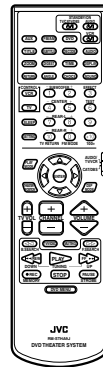

Areas suffix

J ----- U.S.A.
 C ----- Canada

Contents

Safety precautions 1-2
 Important for laser products 1-3
 Preventing static electricity 1-4
 Dismantling and assembling
 the treverse unit 1-5
 Disassembly method 1-8
 Discription of major IC's 1-22

Safety Precautions

1. This design of this product contains special hardware and many circuits and components specially for safety purposes. For continued protection, no changes should be made to the original design unless authorized in writing by the manufacturer. Replacement parts must be identical to those used in the original circuits. Services should be performed by qualified personnel only.
2. Alterations of the design or circuitry of the product should not be made. Any design alterations of the product should not be made. Any design alterations or additions will void the manufacturer's warranty and will further relieve the manufacture of responsibility for personal injury or property damage resulting therefrom.
3. Many electrical and mechanical parts in the products have special safety-related characteristics. These characteristics are often not evident from visual inspection nor can the protection afforded by them necessarily be obtained by using replacement components rated for higher voltage, wattage, etc. Replacement parts which have these special safety characteristics are identified in the Parts List of Service Manual. Electrical components having such features are identified by shading on the schematics and by (Δ) on the Parts List in the Service Manual. The use of a substitute replacement which does not have the same safety characteristics as the recommended replacement parts shown in the Parts List of Service Manual may create shock, fire, or other hazards.
4. The leads in the products are routed and dressed with ties, clamps, tubings, barriers and the like to be separated from live parts, high temperature parts, moving parts and/or sharp edges for the prevention of electric shock and fire hazard. When service is required, the original lead routing and dress should be observed, and it should be confirmed that they have been returned to normal, after re-assembling.
5. Leakage current check (Electrical shock hazard testing)
After re-assembling the product, always perform an isolation check on the exposed metal parts of the product (antenna terminals, knobs, metal cabinet, screw heads, headphone jack, control shafts, etc.) to be sure the product is safe to operate without danger of electrical shock. Do not use a line isolation transformer during this check.

- Plug the AC line cord directly into the AC outlet. Using a "Leakage Current Tester", measure the leakage current from each exposed metal parts of the cabinet, particularly any exposed metal part having a return path to the chassis, to a known good earth ground. Any leakage current must not exceed 0.5mA AC (r.m.s.)
- Alternate check method
Plug the AC line cord directly into the AC outlet. Use an AC voltmeter having, 1,000 ohms per volt or more sensitivity in the following manner. Connect a 1,500 Ω 10W resistor paralleled by a 0.15 μ F AC-type capacitor between an exposed metal part and a known good earth ground. Measure the AC voltage across the resistor with the AC voltmeter.
Move the resistor connection to each exposed metal part, particularly any exposed metal part having a return path to the chassis, and measure the AC voltage across the resistor. Now, reverse the plug in the AC outlet and repeat each measurement. voltage measured Any must not exceed 0.75 V AC (r.m.s.). This corresponds to 0.5 mA AC (r.m.s.).

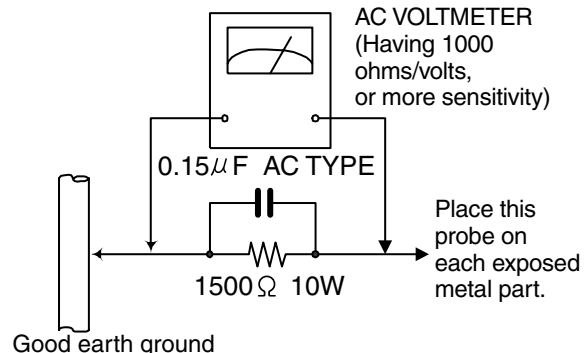

Warning

1. This equipment has been designed and manufactured to meet international safety standards.
2. It is the legal responsibility of the repairer to ensure that these safety standards are maintained.
3. Repairs must be made in accordance with the relevant safety standards.
4. It is essential that safety critical components are replaced by approved parts.
5. If mains voltage selector is provided, check setting for local voltage.

CAUTION Burrs formed during molding may be left over on some parts of the chassis. Therefore, pay attention to such burrs in the case of performing repair of this system.

Important for Laser Products

1. CLASS IIa LASER PRODUCT

2. **DANGER** : Invisible laser radiation when open and interlock failed or defeated. Avoid direct exposure to beam.

3. **CAUTION** : There are no serviceable parts inside the Laser Unit. Do not disassemble the Laser Unit. Replace the complete Laser Unit if it malfunctions.

4. **CAUTION** : The compact disc player uses invisible laser radiation and is equipped with safety switches which prevent emission of radiation when the drawer is open and the safety interlocks have failed or are defeated. It is dangerous to defeat the safety switches.

5. **CAUTION** : If safety switches malfunction, the laser is able to function.

6. **CAUTION** : Use of controls, adjustments or performance of procedures other than those specified herein may result in hazardous radiation exposure.



CAUTION Please use enough caution not to see the beam directly or touch it in case of an adjustment or operation check.

Preventing static electricity

Electrostatic discharge (ESD), which occurs when static electricity stored in the body, fabric, etc. is discharged, can destroy the laser diode in the traverse unit (optical pickup). Take care to prevent this when performing repairs.

1.1. Grounding to prevent damage by static electricity

Static electricity in the work area can destroy the optical pickup (laser diode) in devices such as DVD players. Be careful to use proper grounding in the area where repairs are being performed.

1.1.1. Ground the workbench

1. Ground the workbench by laying conductive material (such as a conductive sheet) or an iron plate over it before placing the traverse unit (optical pickup) on it.

1.1.2. Ground yourself

1. Use an anti-static wrist strap to release any static electricity built up in your body.

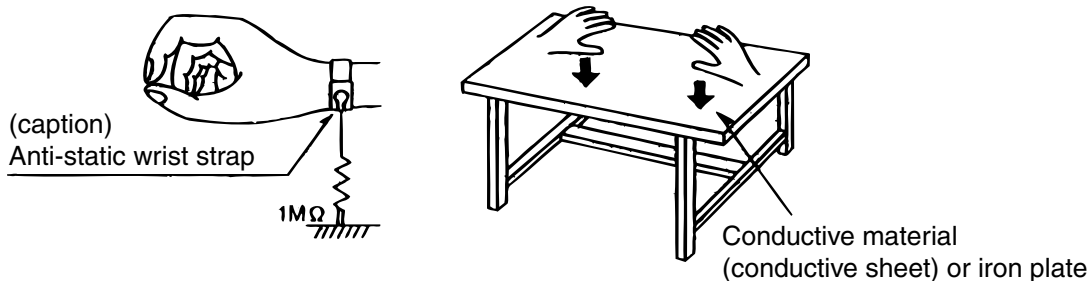

1.1.3. Handling the optical pickup

1. In order to maintain quality during transport and before installation, both sides of the laser diode on the replacement optical pickup are shorted. After replacement, return the shorted parts to their original condition. (Refer to the text.)
2. Do not use a tester to check the condition of the laser diode in the optical pickup. The tester's internal power source can easily destroy the laser diode.

1.2. Handling the traverse unit (optical pickup)

1. Do not subject the traverse unit (optical pickup) to strong shocks, as it is a sensitive, complex unit.
2. Cut off the shorted part of the flexible cable using nippers, etc. after replacing the optical pickup. For specific details, refer to the replacement procedure in the text. Remove the anti-static pin when replacing the traverse unit. Be careful not to take too long a time when attaching it to the connector.
3. Handle the flexible cable carefully as it may break when subjected to strong force.
4. It is not possible to adjust the semi-fixed resistor that adjusts the laser power. Do not turn it

Dismantling and assembling the traverse unit

1. Notice regarding replacement of optical pickup

Electrostatic discharge (ESD), which occurs when static electricity stored in the body, fabric, etc. is discharged, can destroy the laser diode in the traverse unit (optical pickup). Take care to prevent this when performing repairs to the optical pickup or connected devices.

(Refer to the section regarding anti-static measures.)

1. Do not touch the area around the laser diode and actuator.
2. Do not check the laser diode using a tester, as the diode may easily be destroyed.
3. It is recommended that you use a grounded soldering iron when shorting or removing the laser diode.
Recommended soldering iron: HAKKO ESD-compatible product
4. Solder the land on the optical pickup's flexible cable.
 - Note : Short the land after shorting the terminal on the flexible cable using a clip, etc., when using an ungrounded soldering iron.
 - Note : After shorting the laser diode according to the procedure above, remove the solder according to the text explanation.

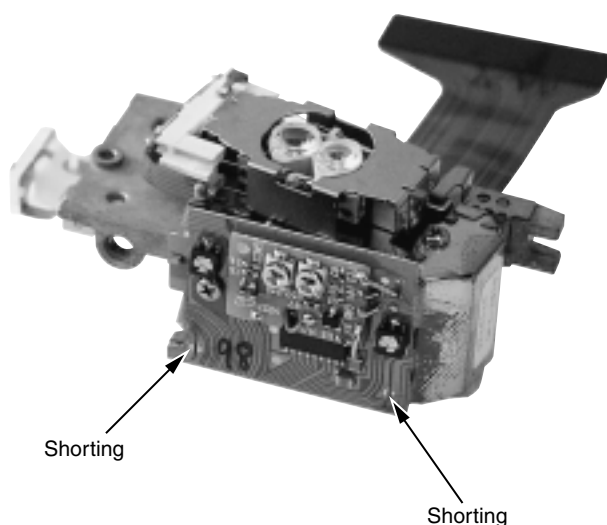

■ Importance Admistering point on the Safety (XV-THA9)

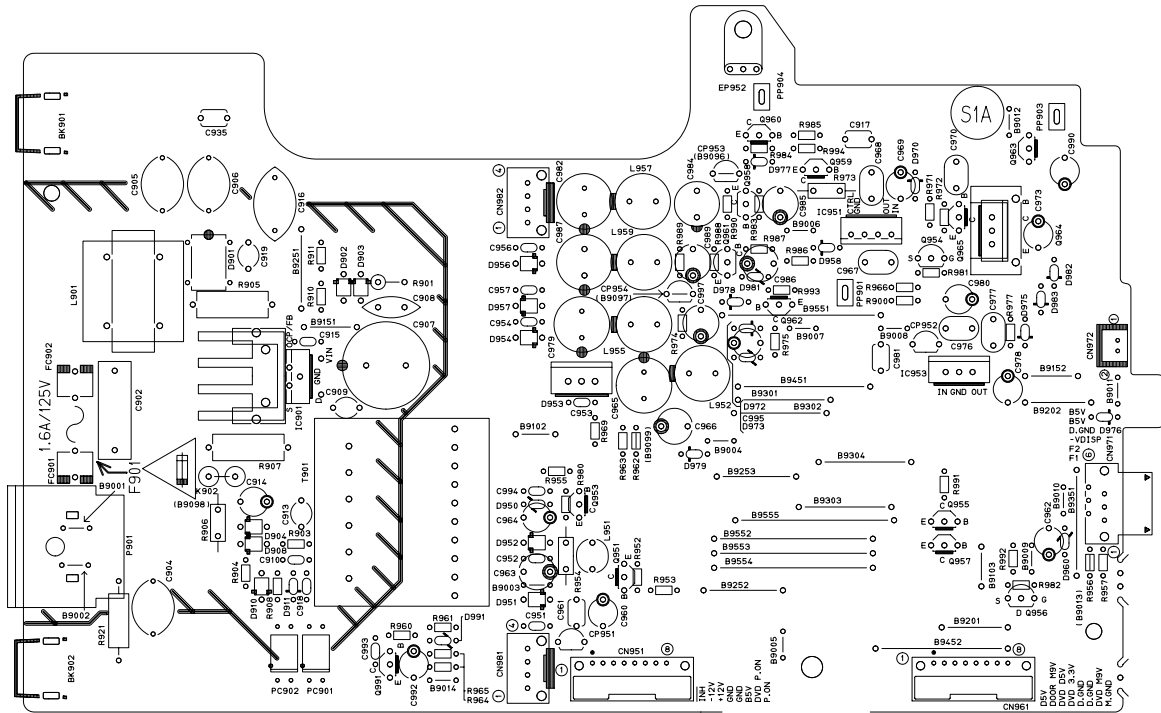



Note : It's means "J" for U.S.A. market model and "C" for canada market model.

<p align="center">XV-THA9 C/J ONLY</p>	<p align="center">XV-THA9 C/J SEULEMENT</p>
<p align="center">Full Fuse Replacement Marking</p> <p>Graphic symbol mark (This symbol means fast blow type fuse.)</p> <div align="center" data-bbox="354 1310 472 1409"> </div> <p align="center">should be read as follows ;</p>	<p align="center">Marquage Pour Le Remplacement Complet De Fusible</p> <p>Le symbole graphique (Ce symbole signifie fusible de type à fusion rapide.)</p> <div align="center" data-bbox="1003 1310 1122 1409"> </div> <p align="center">doit être interprété comme suit ;</p>
<p align="center">FUSE CAUTION</p>	<p align="center">PRECAUTIONS SUR LES FUSIBLES</p>
<p>FOR CONTINUED PROTECTION AGAINST RISK OF FIRE, REPLACE ONLY WITH SAME TYPE AND RATING OF FUSES ;</p> <p align="center">F901 : 1.6 A / 125 V</p>	<p>POUR UNE PROTECTION CONTINUE CONTRE DES RISQUES D'INCENDIE, REMPLACER SEULEMENT PAR UN FUSIBLE DU MEME TYPE ;</p> <p align="center">F901 : 1.6 A / 125 V</p>

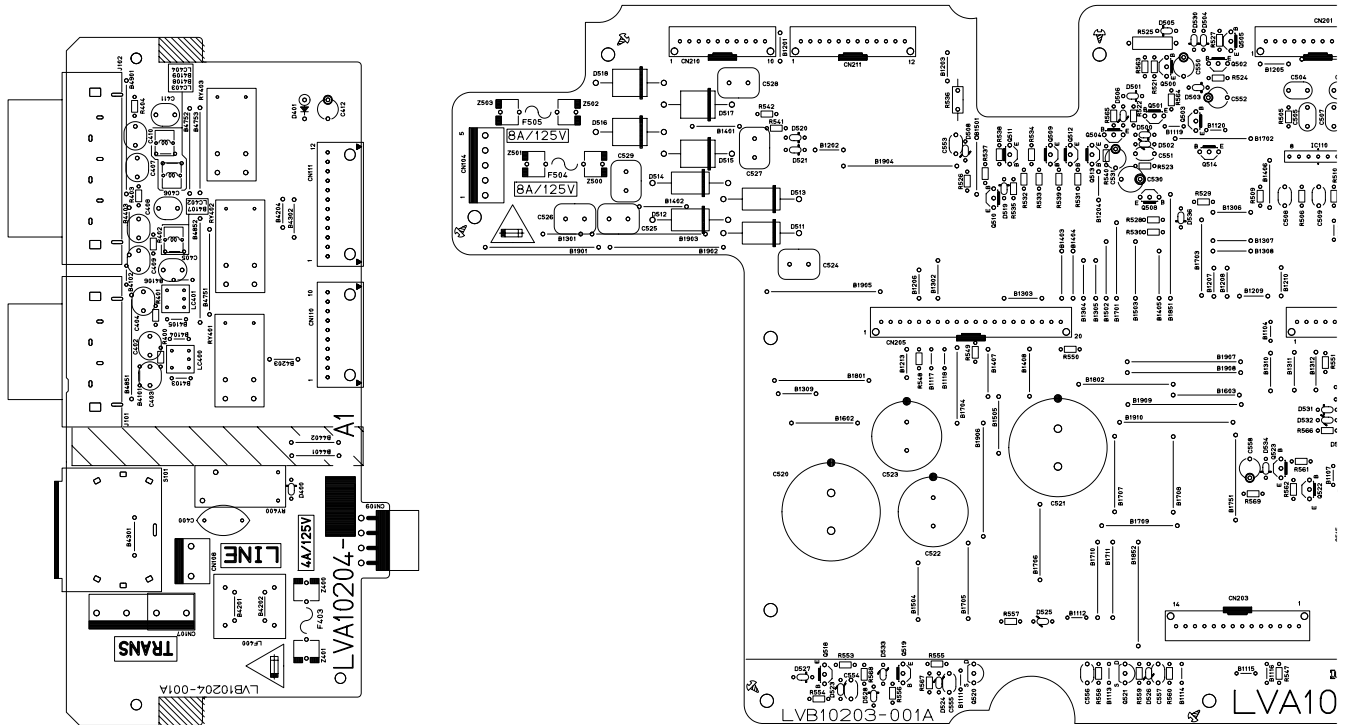
■ Importance Administering point on the Safety (SP-PWA9)

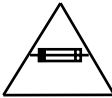

Note : It's means "J" for U.S.A. market model and "C" for canada market model.

<p>SP-PWA9 C/J ONLY</p>	<p>SP-PWA9 C/J SEULEMENT</p>
<p style="text-align: center;">Full Fuse Replacement Marking</p> <p>Graphic symbol mark (This symbol means fast blow type fuse.)</p> <div style="text-align: center;">  </div> <p style="text-align: center;">should be read as follows ;</p>	<p style="text-align: center;">Marquage Pour Le Remplacement Complet De Fusible</p> <p>Le symbole graphique (Ce symbole signifie fusible de type á fusion rapide.)</p> <div style="text-align: center;">  </div> <p style="text-align: center;">doit être interprété comme suit ;</p>
<p>FUSE CAUTION</p>	<p>PRECAUTIONS SUR LES FUSIBLES</p>
<p>FOR CONTINUED PROTECTION AGAINST RISK OF FIRE, REPLACE ONLY WITH SAME TYPE AND RATING OF FUSES ;</p> <p style="text-align: center;"> F401 : 4A / 125 V F504 : 8A / 125 V F505 : 8A / 125 V </p>	<p>POUR UNE PROTECTION CONTINUE CONTRE DES RISQUES D'INCENDIE, REMPLACER SEULEMENT PAR UN FUSIBLE DU MEME TYPE ;</p> <p style="text-align: center;"> F401 : 4A / 125 V F504 : 8A / 125 V F505 : 8A / 125 V </p>

Disassembly method

<Main unit>

■ Removing the DVD door (See Fig.1)

1. Remove the four screws A that retain the DVD door from the top of the unit.

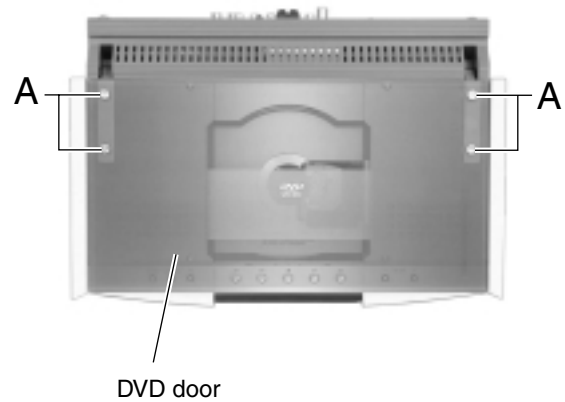

Fig.1

■ Removing the right and left side covers (See Fig.2)

- Prior to performing the following procedure, remove the DVD door.

1. Remove the four screws (B) that attach the left and right side covers of the unit, from the bottom panel.
2. Remove the left and right side covers by moving each of them in the direction of the corresponding arrow.

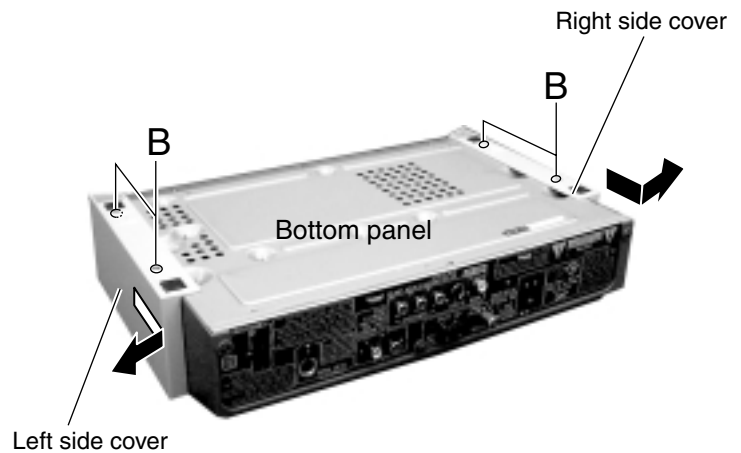

Fig.2

■ Removing the front panel assembly and the DVD mechanism base

(See Figs.3 to 7)

- Prior to performing the following procedure, remove the left and right side covers.
- Also remove the DVD door.

(Note) Remove the front panel assembly and the DVD mechanism together, just as they were assembled.

- The mechanism slide switch for pickup protection should be set to the SHORTED position.

1. Remove the three screws (C) that retain the front panel assembly, from the bottom panel of the unit.
2. Remove four screws (D) that retain the DVD mechanism base, from the top of the unit.
3. Remove the three screws (E) from the rear panel of the unit that retain the DVD mechanism base.
4. Remove the DVD mechanism together with the front panel assembly by lifting them upward from the main unit and moving them toward the front.
5. Disconnect the card wire of the DVD mechanism from the connector CN101 on the DVD servo board.

Disconnect the wire of the LED board from the connector CN812 on the analog input/output board.

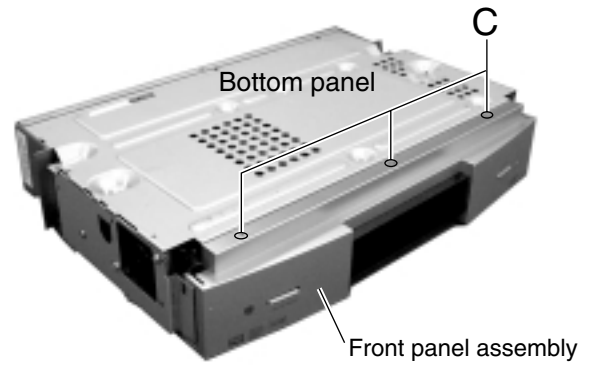

Fig.3

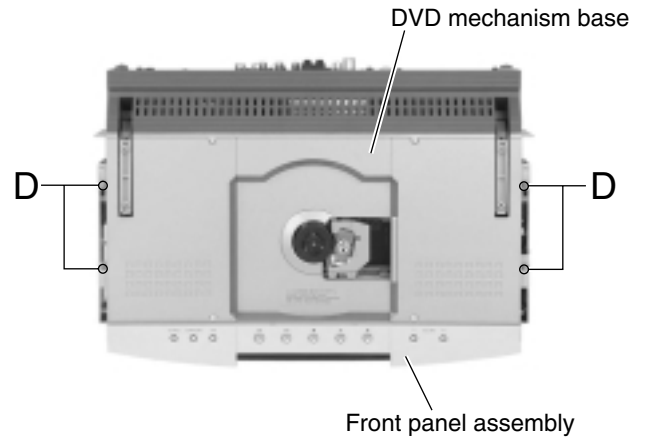

Fig.4

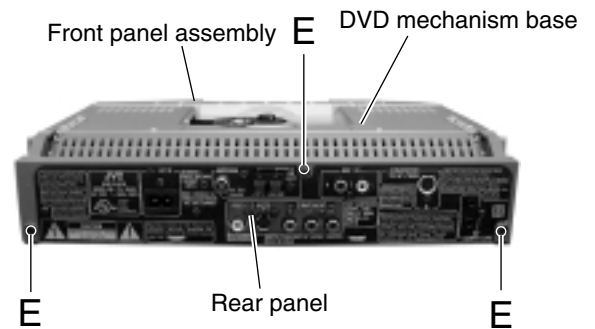

Fig.5

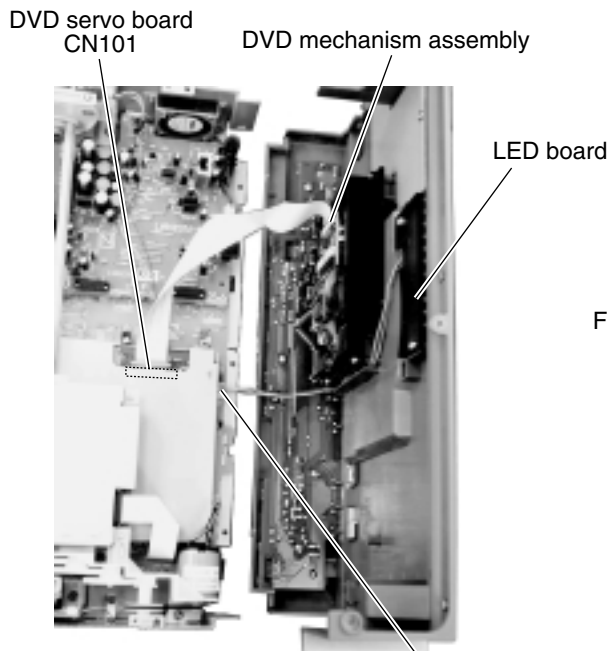

Fig.7

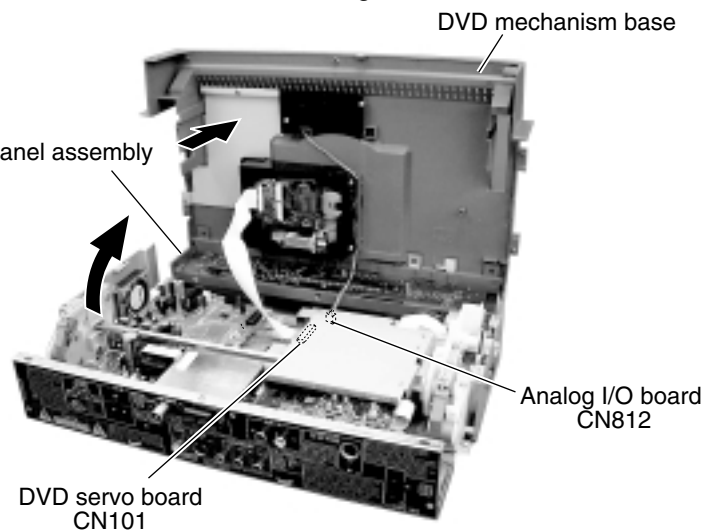

Fig.6

■ Separating the front panel assembly and the DVD mechanism base (See Fig.8)

- Prior to performing the following procedure, remove the left and right side covers.
 - Also remove the DVD door.
1. Remove the front panel assembly and the DVD mechanism base together from the main unit. (See Figs. 3 to 7.)
 2. On the back of the DVD mechanism base, disengage the four claws at the engaging points (a) that attach the front panel assembly to the DVD mechanism base, and then pull out the front panel assembly in the direction of the arrow to separate it from the DVD mechanism base.

(Note) It is at this stage that the front panel assembly and the DVD mechanism base are separated from each other.

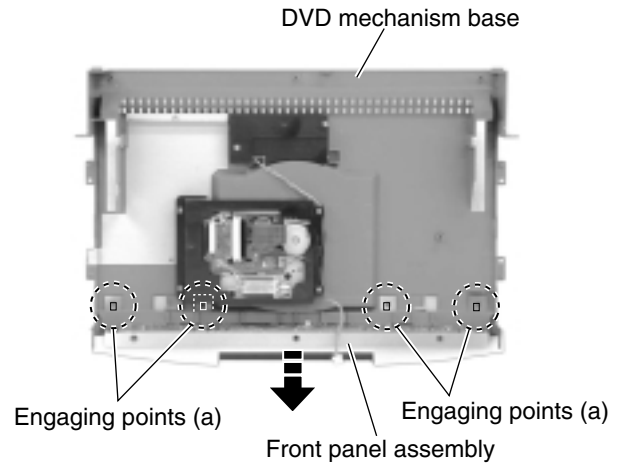

Fig.8

■ Removing the display board (See Fig.9)

- Prior to performing the following procedure, remove the left and right side covers.
- Also remove the DVD door.
- Also separate the front panel assembly from the DVD mechanism base.

1. Remove the five screws (F) that retain the display board.

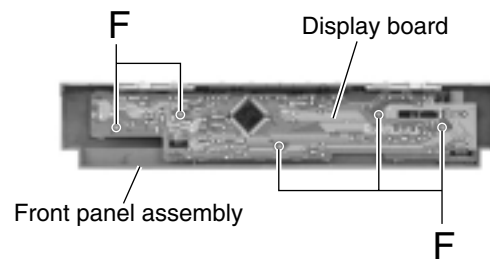

Fig.9

■ Removing the DVD mechanism assembly (See Figs.10 and 11)

- Prior to performing the following procedure, remove the left and right side covers.
- Also remove the DVD door.

(Note) This work is possible even when the front panel assembly is attached to the DVD mechanism base.

1. Remove the four screws (G) from the back of the DVD mechanism base that retain the DVD mechanism cover.
2. Remove the DVD mechanism assembly from the DVD mechanism base.

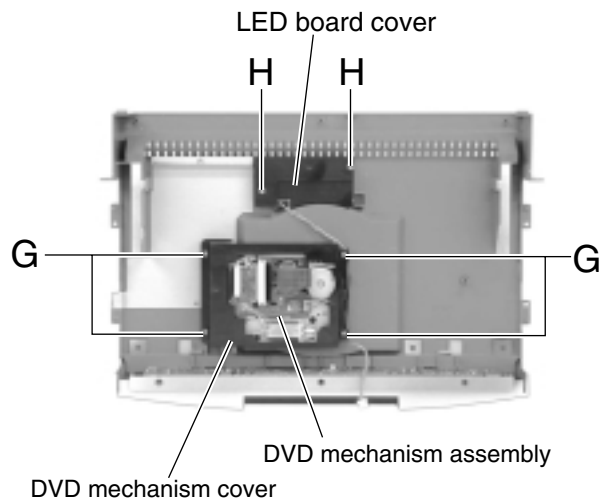

Fig.10

■ Removing the LED board (See Figs.10 and 11)

- Prior to performing the following procedure, remove the left and right side covers.
- Also remove the DVD door.

(Note) This work is possible even when the front panel assembly is attached to the DVD mechanism base.

1. Remove two screws (H) that retain the LED board cover, from the back of the DVD mechanism base.
2. Remove the LED board by pulling it away from the DVD mechanism base.

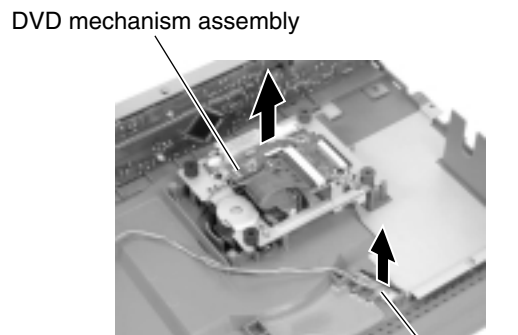

Fig.11

LED board

■ Removing the analog board (See Figs.12 to 14)

- Prior to performing the following procedure, remove the left and right side covers.
- Also remove the DVD door.
- Also remove the front panel assembly and DVD mechanism base.

1. Disconnect the card wires from the connectors CN401 and CN402 on the analog board.
2. Remove the screw (I) that retains the analog board bracket from the top of the unit.
3. Remove the screw (J) and the screw (K) that retain the analog board from the rear panel of the unit.
4. Disengage the analog board bracket and the gear motor assembly by moving the engaged part (b) upward. Then move the analog board in the direction of the arrow, and remove it as if pulling it out of the rear panel.
5. Remove two screws (L) that attach the analog board to the analog board bracket.

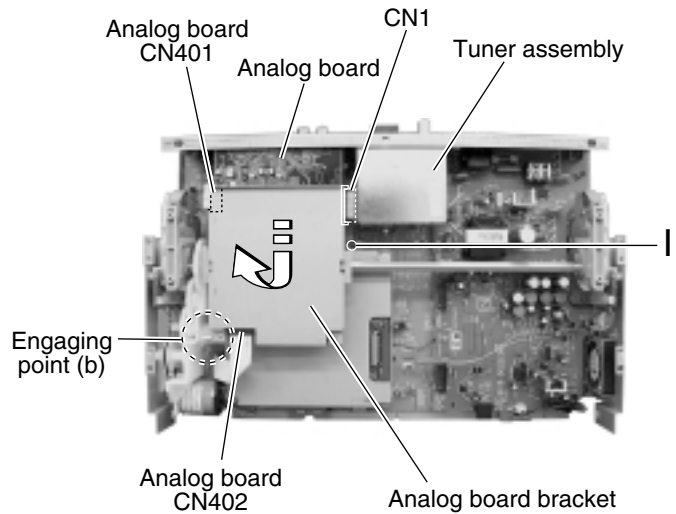

Fig.12

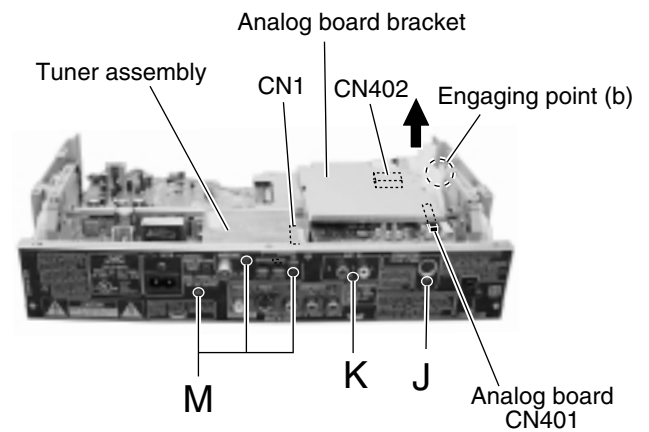

Fig.13

■ Removing the tuner assembly (See Figs.12 and 13)

- Prior to performing the following procedure, remove the left and right side covers.
- Also remove the DVD door.
- Also remove the front panel assembly and the DVD mechanism base.

1. Remove the three screws (M) that retain the tuner assembly, from the rear panel of the unit.
2. Disconnect the card wire from the connector CN1 on the tuner assembly.

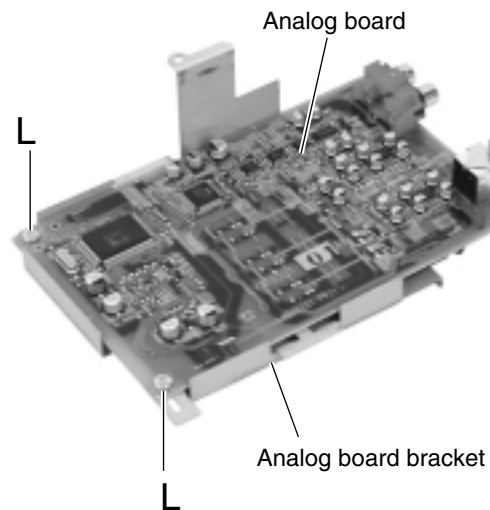
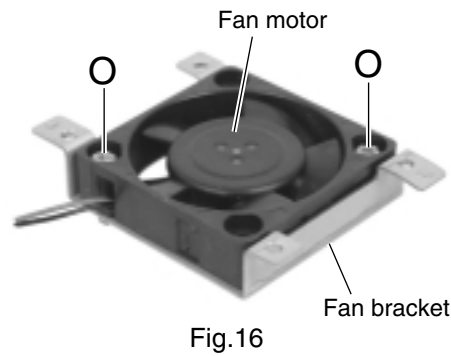
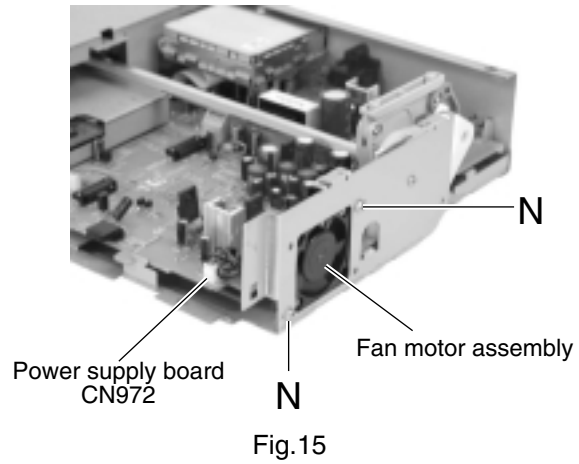

Fig.14

**■Removing the fan motor assembly
(See Figs.15 and 16)**

- Prior to performing the following procedure, remove the left and right side covers.
 - Also remove the DVD door.
 - Also remove the front panel assembly and the DVD mechanism base.
1. Disconnect the wire from the connector CN972 on the power supply board.
 2. Remove the two screws N that retain the fan motor assembly, from the right side of the unit.
 3. Remove the two screws (O) that attach the fan motor assembly to the fan bracket.



**■Removing the gear motor assembly
(See Figs.17 to 19)**

- Prior to performing the following procedure, remove the left and right side covers.
 - Also remove the DVD door.
 - Also remove the front panel assembly and the DVD mechanism base.
 - Also remove the analog board.
1. Disconnect the wire from the connector CN106 on the analog input/output board.
 2. Remove the two screws (P) that retain the gear motor assembly and remove the assembly in the direction of the arrow.

(Note) When reassembling, check that the gear motor assembly is engaged properly with the door arm assembly at the engaging points (c) and (d).

3. Remove the belt from the gear motor assembly.
4. Remove two screws Q that retain the gear motor.

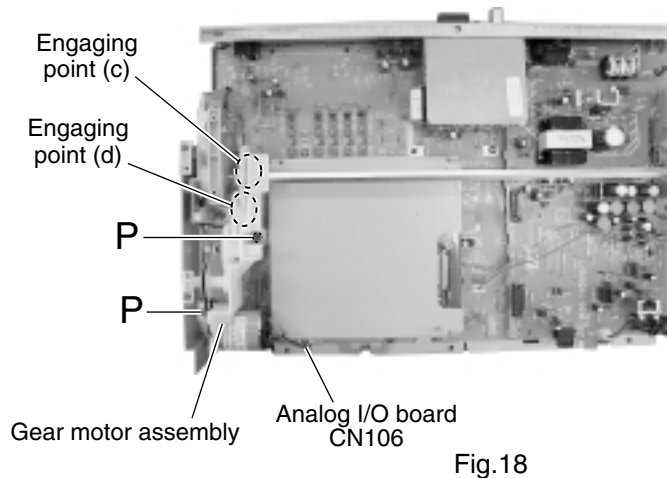
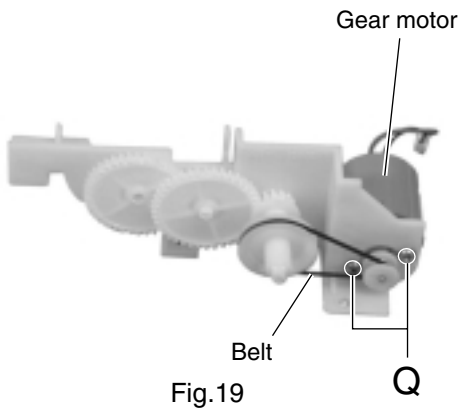
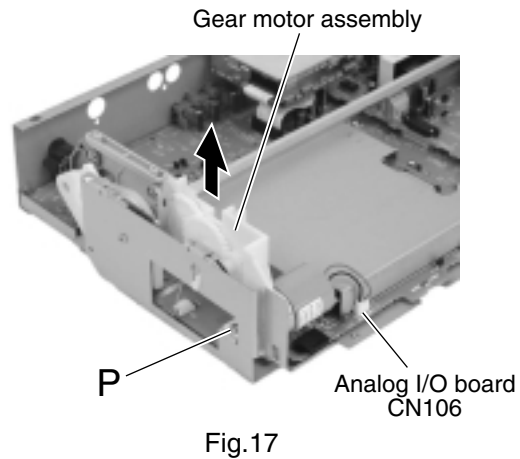

■ Removing the door arm assembly (See Figs.20 to 23)

- Prior to performing the following procedure, remove the left and right side covers.
- Also remove the DVD door.
- Also remove the front panel assembly and the DVD mechanism base.
- Also remove the analog board.
- Also remove the gear motor assembly.

1. Disconnect the wires from the connectors CN810 and CN811 on the analog input/output board.
2. Remove the four screws (R) that retain the door arm assembly, from the top of the unit.
3. Remove the two screws (S) that retain the door arm assembly, from the left and right sides of the unit.

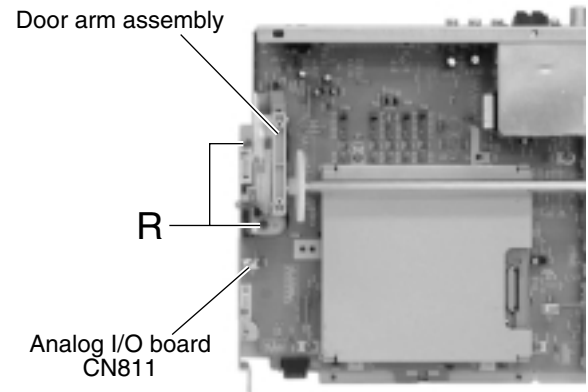

Fig.20

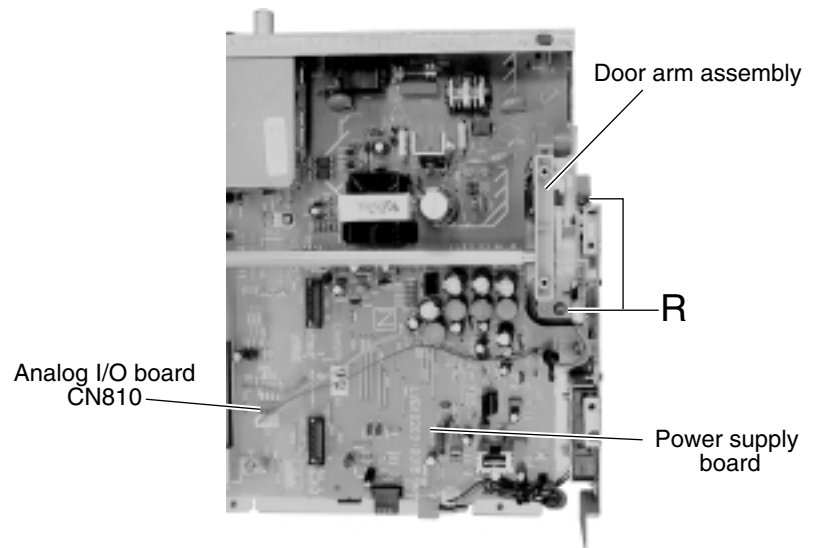

Fig.21

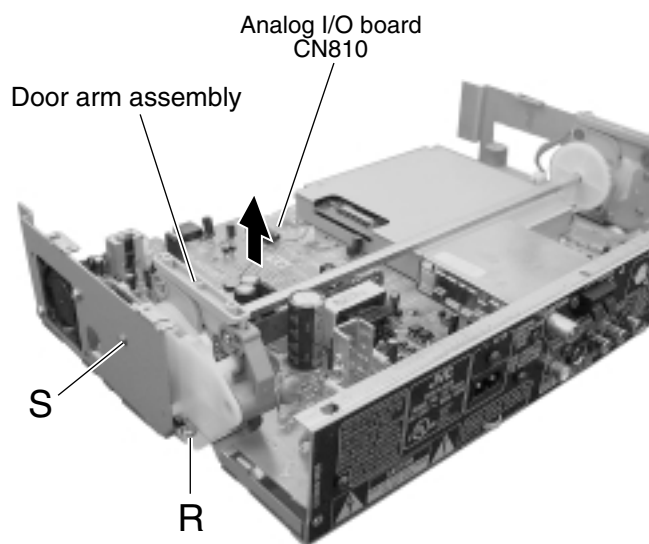

Fig.23

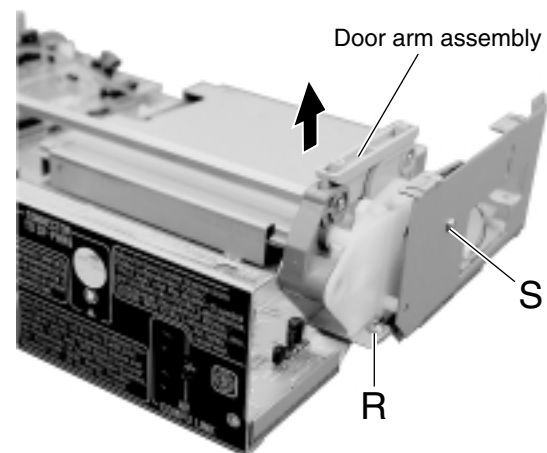

Fig.22

**■Removing the door arm boards (L) and (R)
(See Figs.24 and 25)**

- Prior to performing the following procedure, remove the left and right side covers.
- Also remove the DVD door.
- Also remove the front panel assembly and the DVD mechanism base.
- Also remove the analog board.
- Also remove the gear motor assembly.
- Also remove the door arm assembly.

1. Remove the two screws (U) that retain the door arm board (L).
2. Remove two screws (U) that retain the door arm board (R).

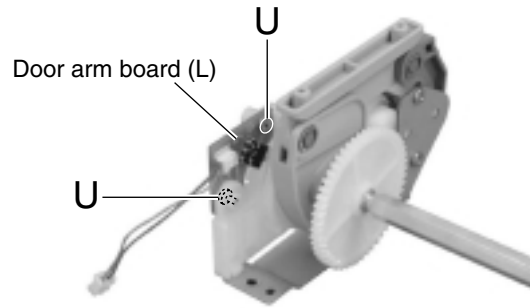

Fig.24

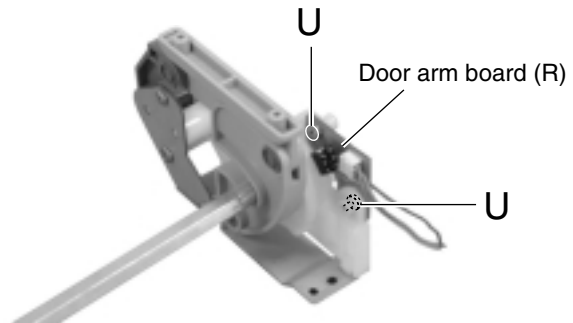

Fig.25

**■Removing the power supply board
(See Figs.26 and 27)**

- Prior to performing the following procedure, remove the left and right side covers.
- Also remove the DVD door.
- Also remove the front panel assembly and the DVD mechanism base.
- Also remove the analog board.
- Also remove the gear motor assembly.
- Also remove the door arm assembly.

1. Remove the screw (V) that retains the power supply board, from the top of the unit.
2. Remove three screws (W) that retain the power supply board, from the rear panel of the unit.
3. Pull out the power supply board from clamp a.
4. Disconnect the wire from the connector CN972 on the power supply board, and then remove the power supply board in the direction of the arrow while unplugging the connectors CN951 and CN952 from the analog input/output board.

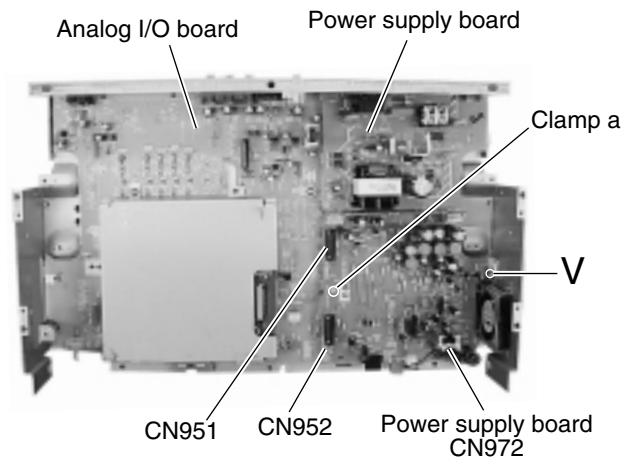

Fig.26

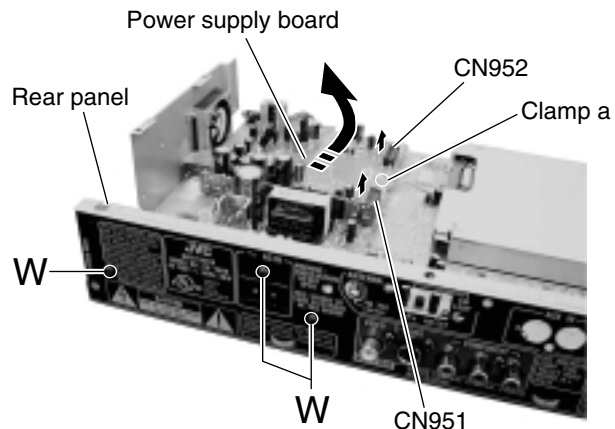

Fig.27

■ Removing the AV decoder board and analog input/output board (See Figs.28 to 30)

- Prior to performing the following procedure, remove the left and right side covers.
- Also remove the DVD door.
- Also remove the front panel assembly and DVD mechanism base.
- Also remove the analog board.
- Also remove the gear motor assembly.
- Also remove the door arm assembly.

1. Remove the three screws (X) that retain the AV decoder board cover, from the top of the unit and remove the screw (X) that retains the analog input/output board.
2. IF it is required to separate the AV decoder board from the analog input/output board, unplug the connectors CN501, CN502 and CN503 on the AV decoder board from the analog input/output board.

(Note) The analog input/output board can be removed even when it is engaged with the AV decoder board.

3. Remove the four screws (Y) that retain the analog input/output board, from the rear panel of the unit. This procedure also detaches the rear panel.

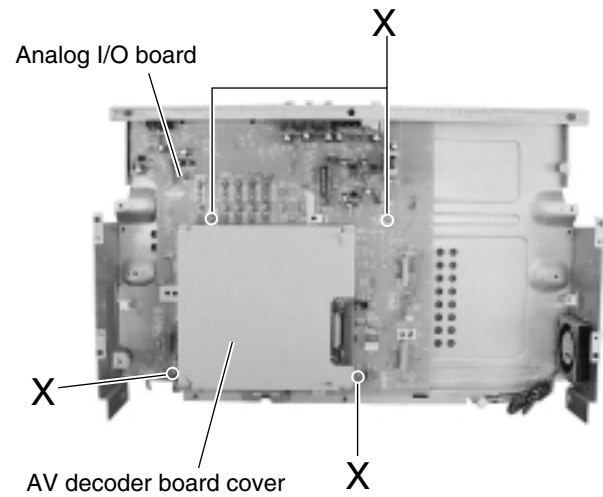

Fig.28

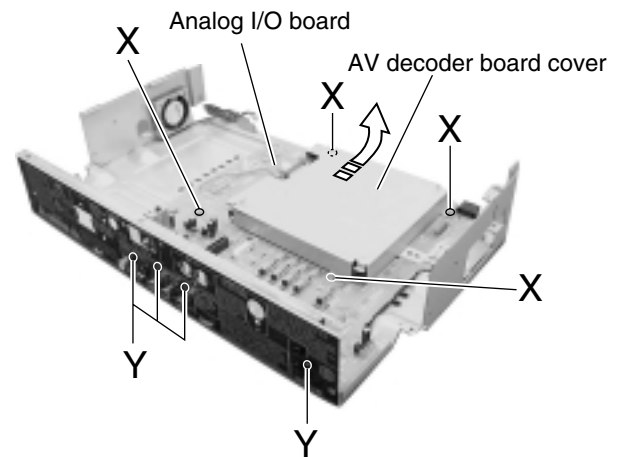

Fig.29

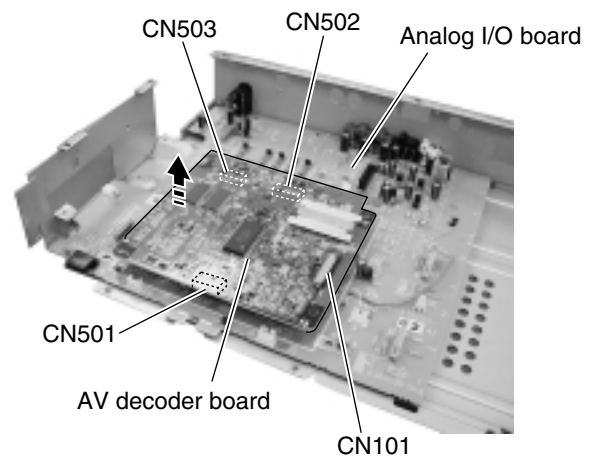

Fig.30

Disassembly method

<Speaker>

■ Removing the heat sink cover (See Fig.1)

1. Remove the four screws A attaching the heat sink cover.

■ Removing the amplifier assembly and the amplifier cover (See Figs.2 and 3)

- Prior to performing the following procedure, remove the heat sink.

1. Remove the eight screws B attaching the amplifier assembly on the back of the body.
2. Move the amplifier assembly backward and disconnect the harness from connector CN109 in the lower part of the amplifier assembly.
3. Pull out the volume knob.
4. Remove the ten screws C attaching the heat sink cover.
5. Remove the ten screws D and the one screw E attaching the amplifier cover.

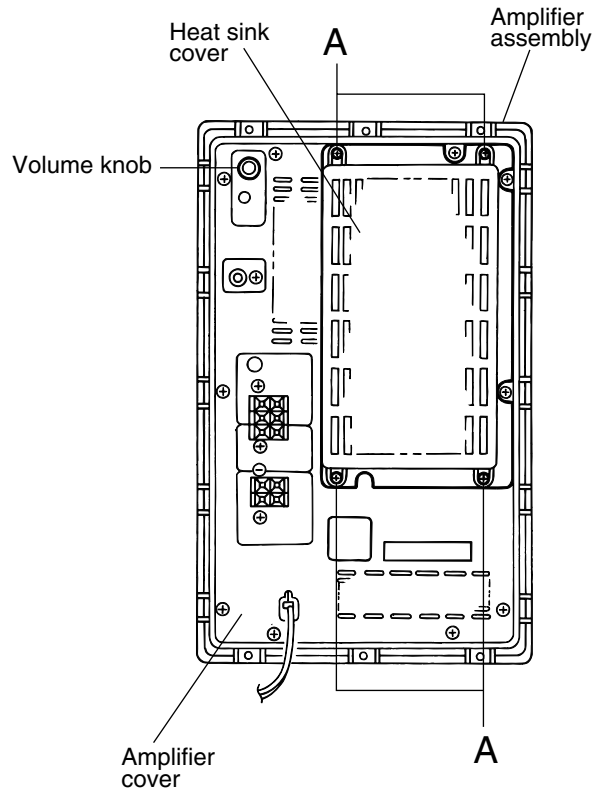

Fig.1

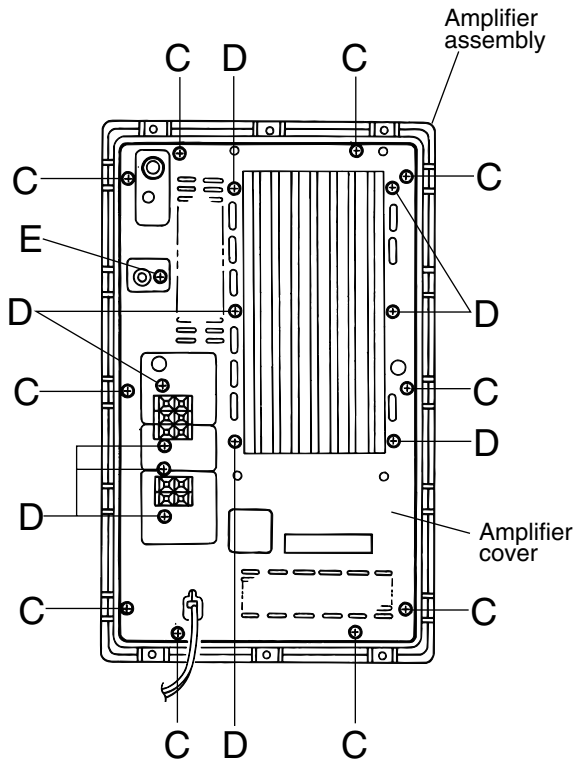

Fig.3

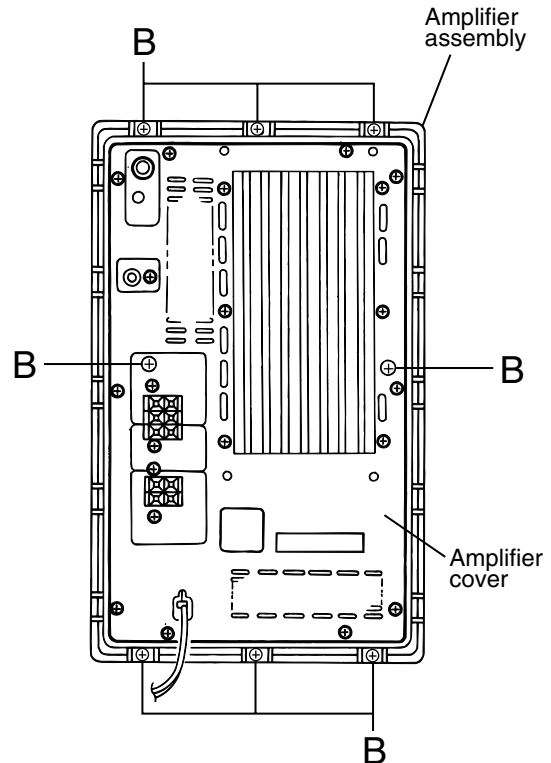

Fig.2

■ Removing the preamplifier board (See Figs.4 to 6)

• Prior to performing the following procedure, remove the heat sink cover, the amplifier assembly and the amplifier cover.

1. Remove the two screws F attaching the preamplifier board to the bracket.
2. Disconnect connector CN101 on the preamplifier board from the main amplifier board.
3. Pull out the switch knob.
4. Remove the nut and the two screws G attaching the bracket.

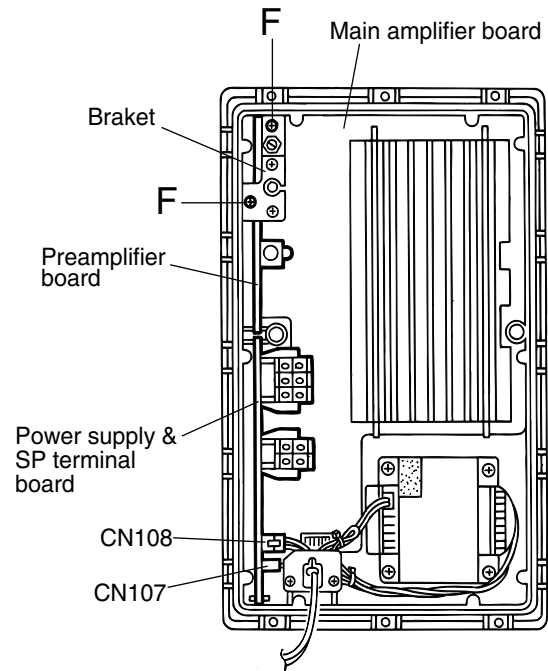

Fig.4

■ Removing the power supply & SP terminal board (See Figs.4 and 5)

• Prior to performing the following procedure, remove the heat sink cover, amplifier assembly and the amplifier cover.

1. Disconnect the wire from the connectors CN107 and CN108 on the power supply & SP terminal board.
2. Unplug the connectors CN110 and CN111 on the power supply & SP terminal board from the main amplifier board.

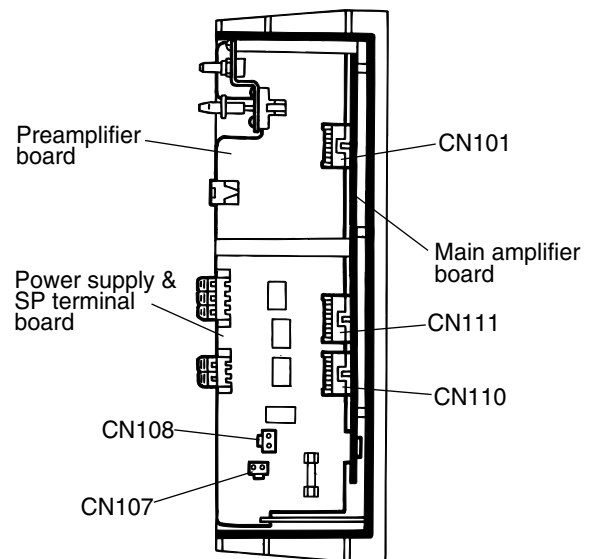

Fig.5

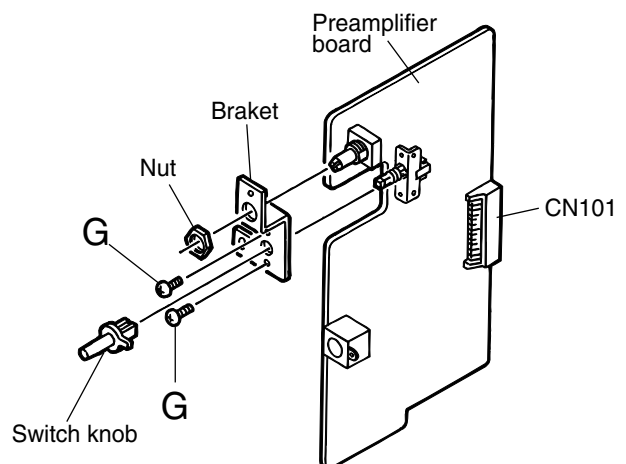

Fig.6

■ Removing the Main amplifier Board (See Figs.7 and 8)

- Prior to performing the following procedure, remove the heat sink cover, the amplifier board, the amplifier cover, the preamplifier board and the power supply & SP terminal board.
1. Disconnect the harness from connector CN104 on the main amplifier board.
 2. Remove the seven screws H and the main amplifier board with the heat sink.
 3. Remove the two screws I attaching the power amplifier board (A) and the two screws J attaching the power amplifier board (B) on the underside of the main amplifier board.
 4. Disconnect connector CN102 and CN103 on the power amplifier board (A) and CN105 and CN106 on the power amplifier board (B) from the main amplifier board respectively.

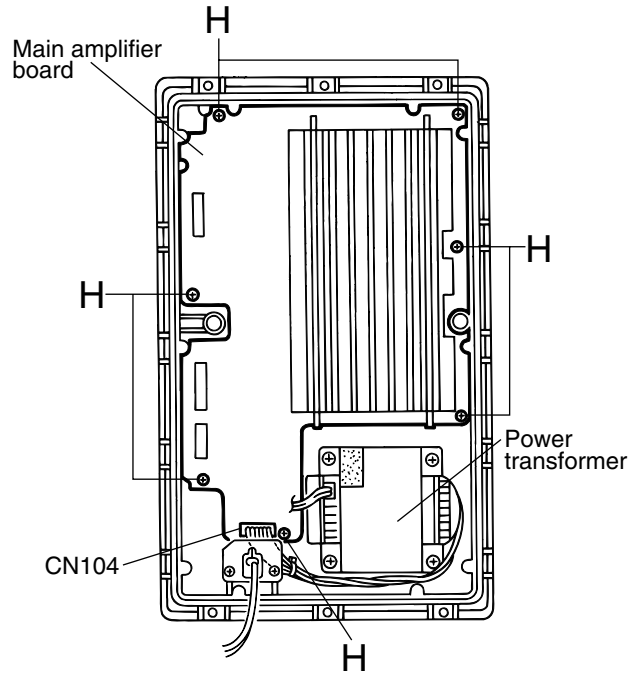

Fig.7

■ Removing the power amplifier board (A) (See Figs.9 and 10)

- Prior to performing the following procedure, remove the heat sink cover, amplifier assembly, the amplifier cover, the preamplifier board, the power supply & SP terminal board, the main amplifier board.
1. Remove the four screws K attaching the power amplifier board (A) to the heat sink.
 2. Release the four joint hooks a bent and attached to the outside of the power amplifier board (A).
 3. Move the power amplifier board (A) in the direction of the arrow to release joint b and remove the power amplifier board (A) from the bracket (A).

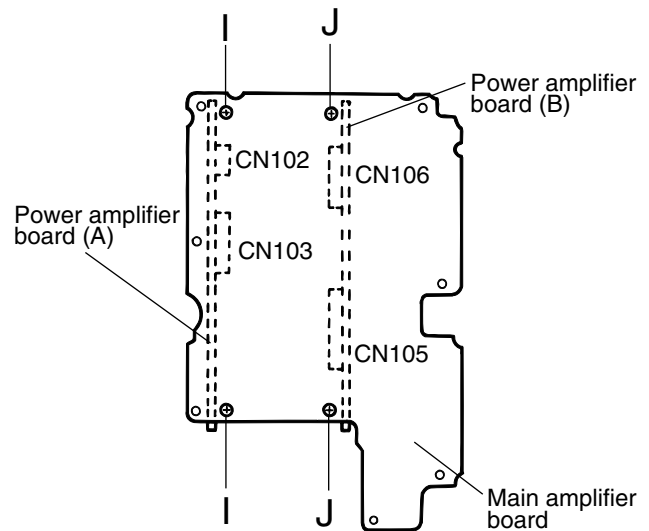

Fig.8

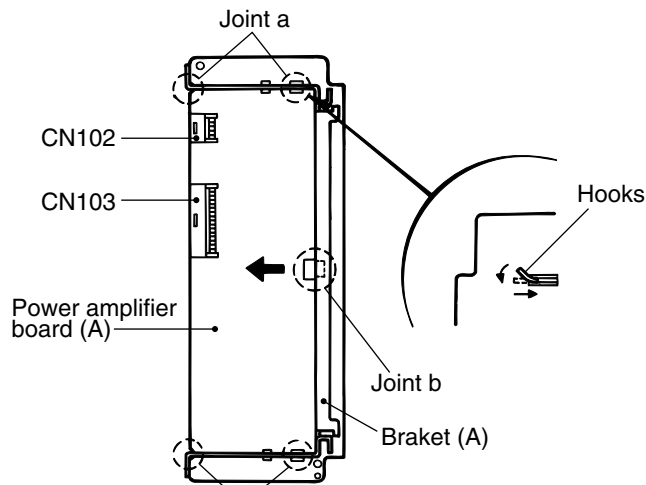

Fig.10

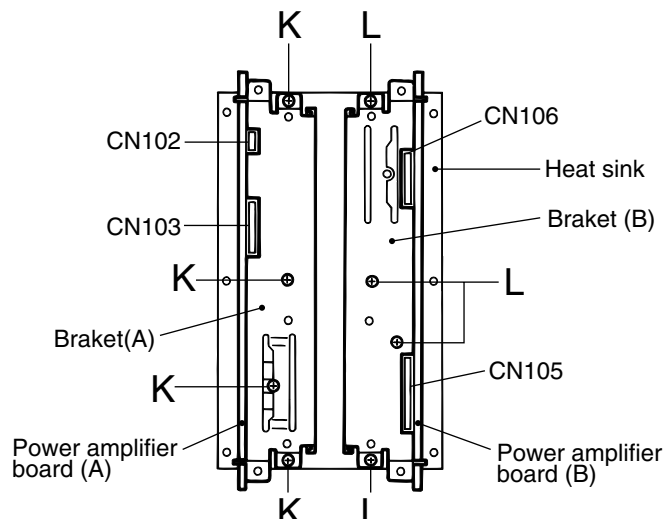

Fig.9

■ Removing the power amplifier board (B) (See Figs.9 and 11)

• Prior to performing the following procedure, remove the heat sink cover, the amplifier assembly, the amplifier cover, the preamplifier board, the power supply & SP terminal board, the main amplifier board and power amplifier board (A).

1. Remove the four screws L attaching the power amplifier board (B) to the heat sink.
2. Release the four joint hooks c bent and attached to the outside of the power amplifier board (B).
3. Move the power amplifier board (B) in the direction of the arrow to release joint d and remove the power amplifier board (B) from the bracket (B).

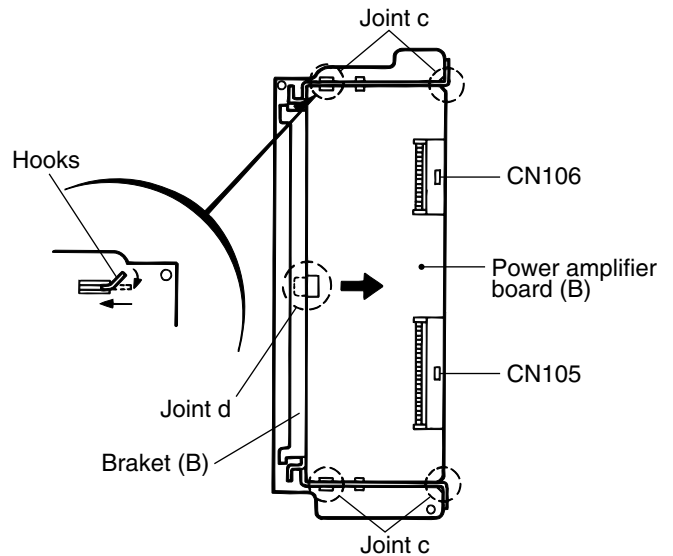

Fig.11

■ Removing the power transformer (See Figs.12 and 13)

• Prior to performing the following procedure, remove the heat sink cover, the amplifier assembly, the amplifier cover, the preamplifier board, the power supply & SP terminal board, the main amplifier board, the power amplifier board (A) and power amplifier board (B).

1. Disconnect the harness from connector CN104 on the main amplifier board.
2. Disconnect the wire from connector CN107 on the power supply & SP terminal board.
3. Remove the four screws M attaching the power transformer.

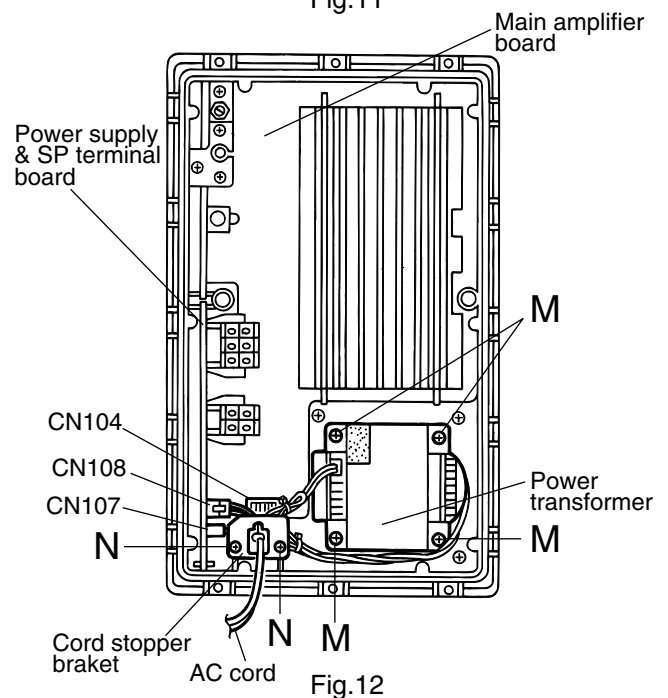

Fig.12

■ Removing the AC power cord (See Fig.12)

• Prior to performing the following procedure, remove the heat sink cover, the amplifier assembly, the amplifier cover, the preamplifier board, the power supply & SP terminal board, the main amplifier board, the power amplifier board (A), the power amplifier board (B) and power transformer.

1. Disconnect the wire from connector CN108 on the power supply & SP terminal board.
2. Remove the two screws N attaching the AC power cord.

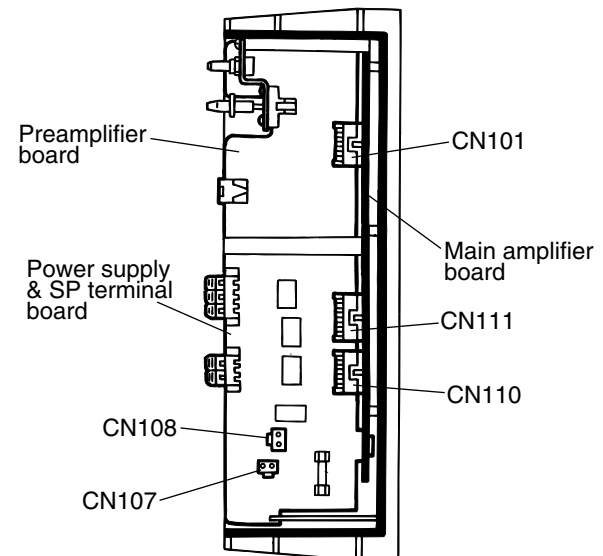

Fig.13

■ Initialization of EEPROM

1. Make sure that no disc is present on the tray.
2. At first push the power switch to be on. Then the door slides to the position to be able to push the stop button. After that pull AC plug out.
3. While holding the STOP and OPEN/CLOSE keys on the main unit depressed, turn on the primary power supply.
4. The FL display should show "TEST JC 1".
5. Press the ENTER key on the remote controller.
Initialization of the EEPROM starts (and lasts for about 3 seconds). The initialization has completed when the FL display shows "EEPROM" at the center.
6. Now the EEPROM initialization is complete.
No key is accepted during the EEPROM initialization.
To exit from the test mode, press the POWER key to enter the STAND-BY mode.

■ Display of the laser current value

1. While holding the STOP and OPEN/CLOSE keys on the main unit depressed, plug the AC power cord into the power outlet.
2. The FL display should show "TEST".
Note: When the power is in the STAND-BY mode or OFF, the stop key is hidden behind the door.
Therefore, to facilitate the entry in the test mode, slide the door in advance so that the STOP key can be pressed even when the AC power is turned off by unplugging the AC power cord.
3. Press the "5" key on the remote controller in the test mode. The DVD laser will turn on and the FL display will show a message such as "03EXXX". As the FL display shows a hexadecimal value, check the actual current value by referring to the conversion table to see if it is OK or not. (The actual laser current value is calculated by subtracting 15 mA from the value obtained with the conversion table.)
4. To exit from the test mode, press the POWER key to enter the STAND-BY (power off) mode.

FL Display conversion table

1.Current

FL Display	Current(mA)	Evaluation	FL Display	Current(mA)	Evaluation	FL Display	Current(mA)	Evaluation
001c,001b	25	OK	03E5	59	OK	03AF,03AE	93	NG
001A	26	OK	03E4,03E3	60	OK	03Ad	94	NG
0019,0018	27	OK	03E2	61	OK	03Ac,03Ab	95	NG
0017	28	OK	03E1,03E0	62	OK	03AA,03A9	96	NG
0016,0015	29	OK	03dF,03dE,	63	OK	03A8	97	NG
0014,0013	30	OK	03dd	64	OK	03A7,03A6	98	NG
0012	31	OK	03dc,03db	65	NG	03A5	99	NG
0011,0010	32	OK	03dA	66	NG	03A4,03A3	100	NG
000f	33	OK	03d9,03d8	67	NG	03A2,03A1	101	NG
000e,000d	34	OK	03d7,03d6	68	NG	03A0	102	NG
000c,000b	35	OK	03d5	69	NG	039F,039E	103	NG
000A	36	OK	03d4,03d3	70	NG	039d,039c	104	NG
0009,0008	37	OK	03d2	71	NG	039b	105	NG
0007	38	OK	03d1,03d0	72	NG	039A,0399	106	NG
0006,0005	39	OK	03cF,03cE	73	NG	0398	107	NG
0004,0003	40	OK	03cd	74	NG	0397	108	NG
0002	41	OK	03cc,03cb	75	NG			
0001,0000	42	OK	03cA,03c9	76	NG			
03FF	43	OK	03c8	77	NG			
03FE,03Fd	44	OK	03c7,03c6	78	NG			
03Fc,03Fb	45	OK	03c5	79	NG			
03FA	46	OK	03c4,03c3	80	NG			
03F9,03F8	47	OK	03c2,03c1	81	NG			
03F7	48	OK	03c0	82	NG			
03F6,03F5	49	OK	03bF,03bE	83	NG			
03F4,03F3	50	OK	03bd	84	NG			
03F2	51	OK	03bc,03bb	85	NG			
03F1,03F0	52	OK	03bA,03b9	86	NG			
03EF,03EE	53	OK	03b8	87	NG			
03Ed	54	OK	03b7,03b6	88	NG			
03Ec,03Eb	55	OK	03b5	89	NG			
03EA	56	OK	03b4,03b3	90	NG			
03E9,03E8	57	OK	03b2,03b1	91	NG			
03E7,03E6	58	OK	03b0	92	NG			

Description of major IC's

■ AK93C65AF-X(IC403) : EEPROM

1. Terminal layout

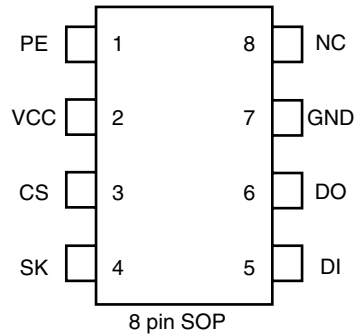

2. Block diagram

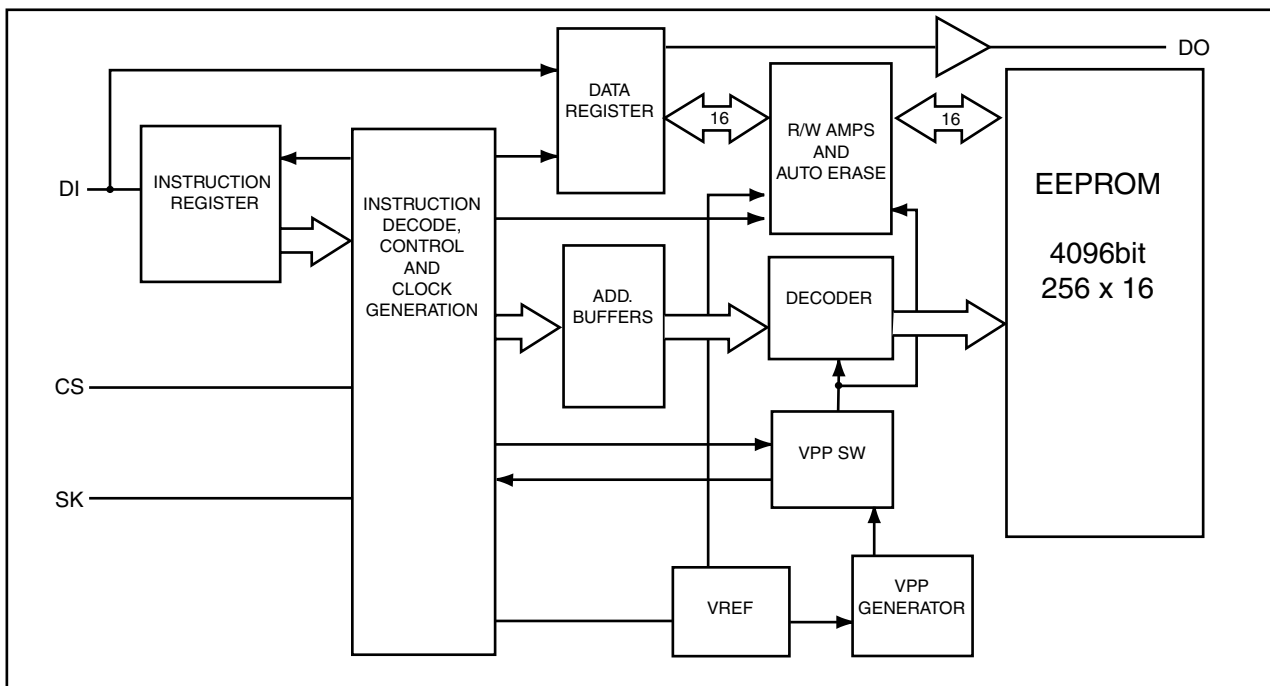

3. Pin function

Pin No.	Symbol	Function
1	PE	Program enable (With built-in pull up resistor)
2	VCC	Power supply
3	CS	Chip selection
4	SK	Serial clock input
5	DI	Serial data input
6	DO	Serial data output
7	GND	Ground
8	NC	No connection

Note : The pull-up resistor of the PE pin is about 2.5 M Ω (VCC=5V)

■ AN8702FH (IC101) : Frontend processor

1. Pin layout

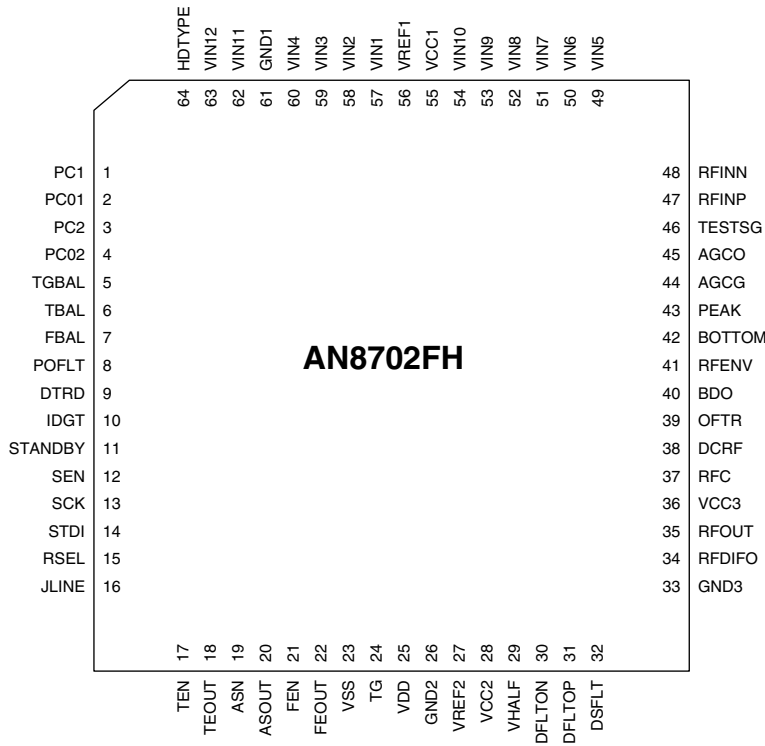

2. Pin function

AN8702FH

Pin No.	Symbol	I/O	Function	Pin No.	Symbol	I/O	Function
1	PC1			33	GND3	-	Earth terminal 3
2	PC01			34	RFDIFO		
3	PC2			35	RFOUT		
4	PC02			36	VCC3	-	Power terminal 3 (5V)
5	TGBAL	I	Tangential phase balance control terminal	37	RFC		
6	TBAL	I	Tracking balance control terminal	38	DCRF	O	BDO output terminal
7	FBAL	I	Focus balance control terminal	39	OFTR	O	OFTR output terminal
8	POFLT	O	Track detection threshold value level terminal	40	BDO	O	BDO output terminal
9	DTRD	I	Data slice data read signal input terminal (For RAM)	41	RFENV	O	RF env output terminal
10	IDGT	I	Data slice part address part gate signal input terminal (For RAM)	42	BOTTOM	O	Bottom env detection filter terminal
11	STANDBY	I	Standby mode control terminal	43	PEAK	O	Peak env detection filter terminal
12	SEN	I	SEN(Sereal data input terminal)	44	AGCG	O	AGC amplifier gain control terminal
13	SCK	I	SCK(Sereal data input terminal)	45	AGCO		
14	STDI	I	STDI(Sereal data input terminal)	46	TESTSG	I	TEST signal input terminal
15	RSEL			47	RFINP	I	RF signal positive moving input terminal
16	JLINE			48	RFINN	I	RF signal reversing input terminal
17	TEN			49	VIN5	I	Focus input of external division into two terminal
18	TEOUT	O	Tracking error signal output terminal	50	VIN6	I	Focus input of external division into two terminal
19	ASN			51	VIN7	I	
20	ASOUT			52	VIN8	I	
21	FEN	I	Focus error output amplifier reversing input terminal	53	VIN9	I	
22	FEOUT	O	Focus error signal output terminal	54	VIN10	I	
23	VSS	-	Earth terminal	55	VCC1	-	Power terminal 1
24	TG	O	Tangential phase error signal output terminal	56	VREF1	O	VREF1 voltage output terminal
25	VDD	-	Power terminal (3V)	57	VIN1	I	External division into four (DVD/CD) RF input terminal 1
26	GND2	-	Earth terminal 2	58	VIN2	I	External division into four (DVD/CD) RF input terminal 2
27	VREF2	O	VREF2 voltage output terminal	59	VIN3	I	External division into four (DVD/CD) RF input terminal 3
28	VCC2	-	Power terminal (5V)	60	VIN4	I	External division into four (DVD/CD) RF input terminal 4
29	VHALF	O	VHALF voltage output terminal	61	GND1	-	Earth terminal 1
30	DFLTON			62	VIN11	I	
31	DFLTOP			63	VIN12	I	
32	DSFLT			64	HDTYPE		

■ HY57V161610DTC8 or KM416S1120DT-G8 (IC504,IC505) : 16MB SDRAM

1. Block diagram

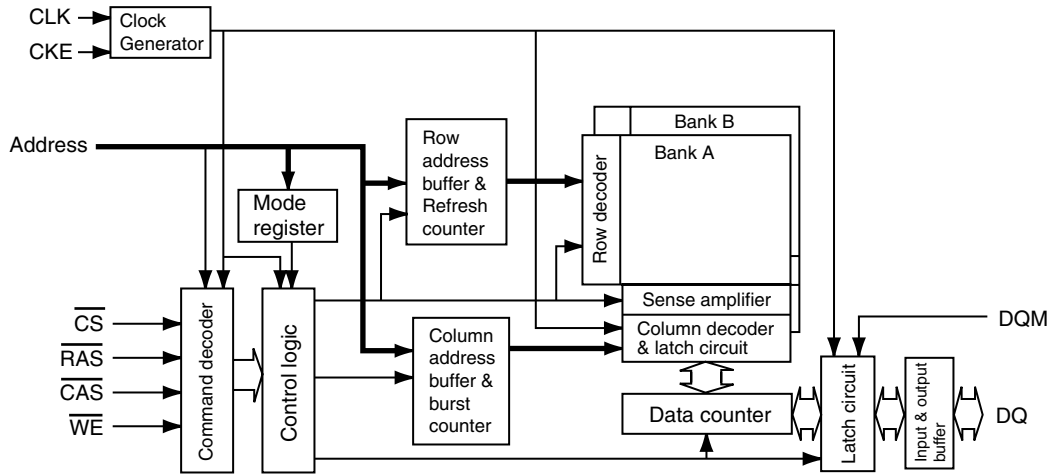

2. Pin function

Pin No.	Symbol	Description	Pin No.	Symbol	Description
1	VCC	Power supply	26	VSS	Connect to GND
2,3	DQ0,1	Data input/output	27~32	A4~9	Address inputs
4	VSS	Connect to GND	33	NC	Non connect
5,6	DQ2,3	Data input/output	34	CKE	Clock enable
7	VDD	Power supply	35	CLK	System clock input
8,9	DQ4,5	Data input/output	36	UDQM	Upper DQ mask enable
10	VSS	Connect to GND	37	NC	Non connect
11,12	DQ6,7	Data input/output	38	VCC	Power supply
13	VCC	Power supply	39,40	DQ8,9	Data input/output
14	LDQM	Lower DQ mask enable	41	VSS	Connect to GND
15	\overline{WE}	Write enable	42,43	DQ10,11	Data input/output
16	\overline{CAS}	Column address strobe	44	VDD	Power supply
17	\overline{RAS}	Row address strobe	45,46	DQ12,13	Data input/output
18	\overline{CS}	Chip enable	47	VSS	Connect to GND
19,20	A11,10	Address inputs	48,49	DQ14,15	Data input/output
21~24	A0~3	Address inputs	50	VSS	Connect to GND
25	VCC	Power supply			

M56788FP-W(IC271) : Traverse mechanism driver

1.Pin layout

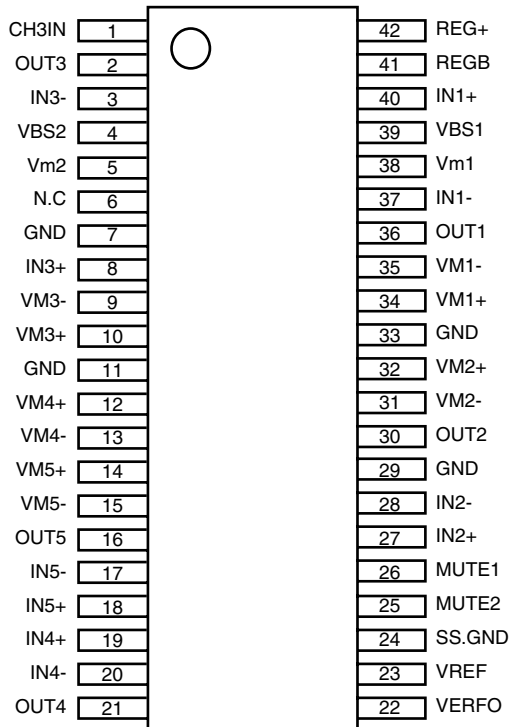

2.Block diagram

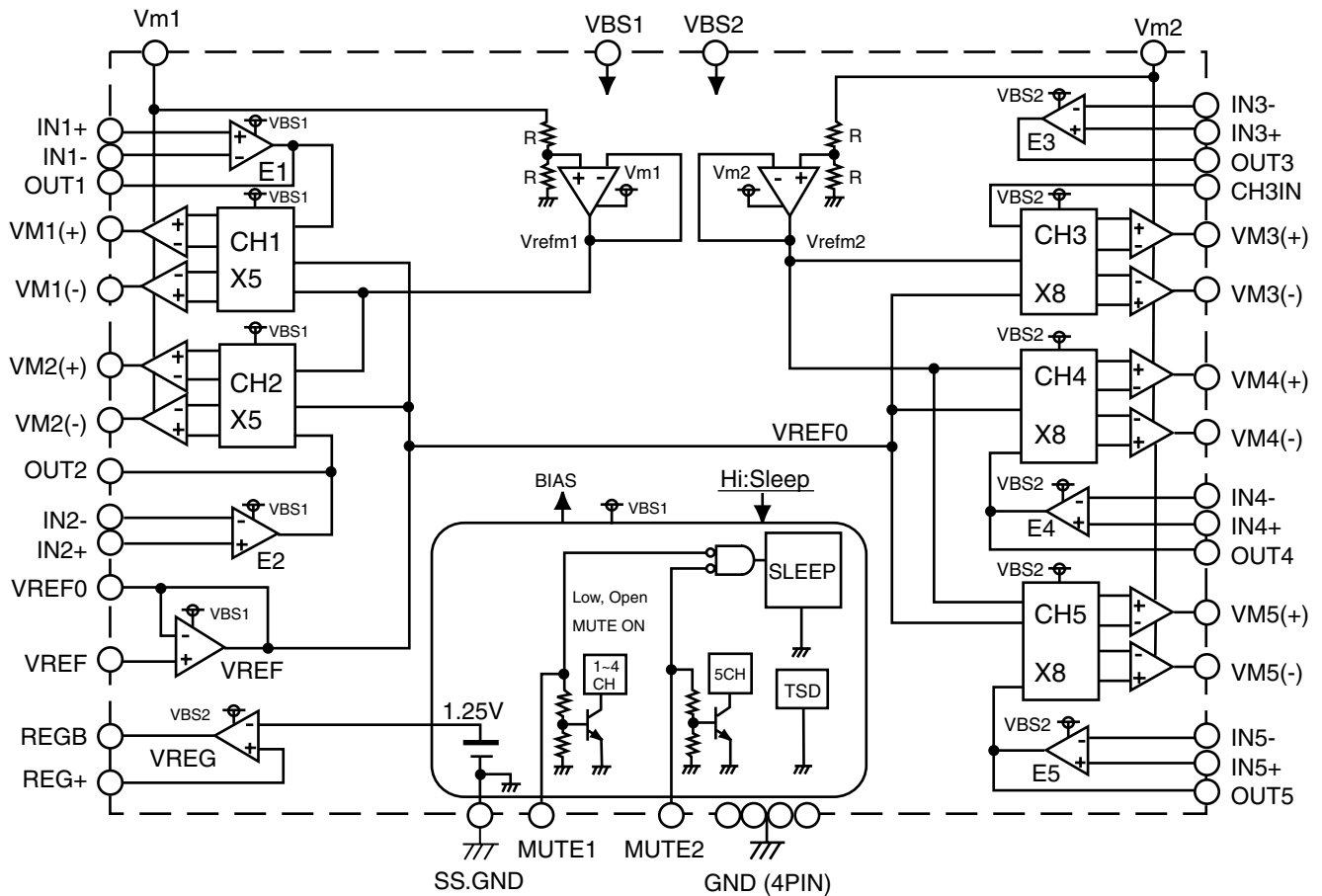

MC44724AVFU (IC554) : VIDEO ENCODER

1. Terminal layout

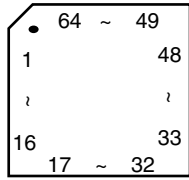

2. Block diagrams

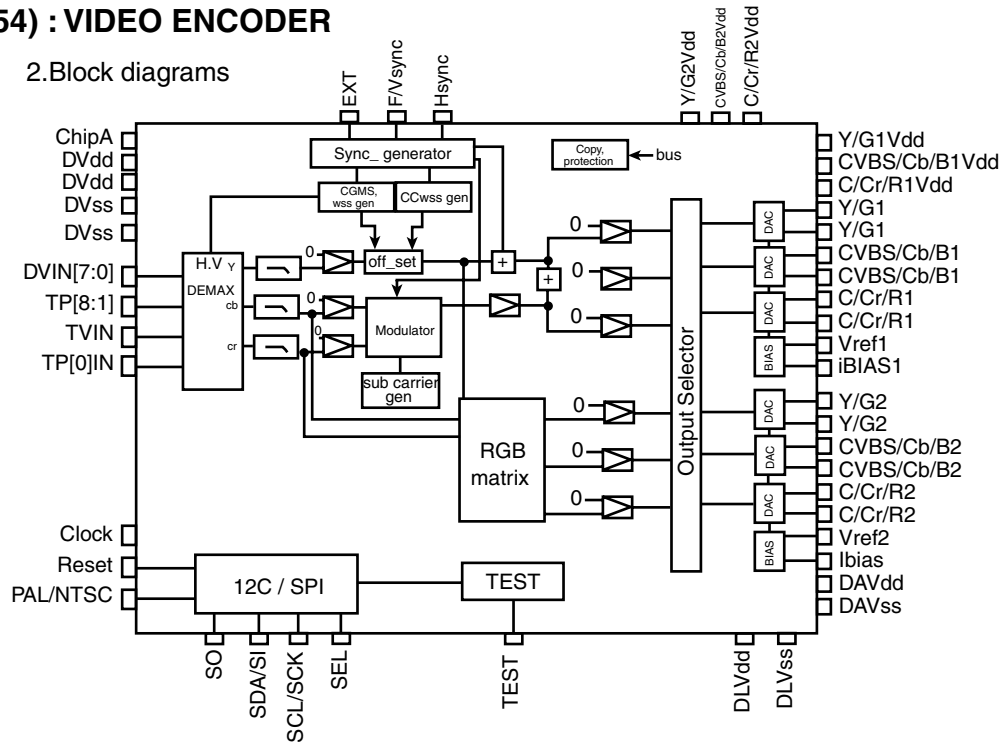

3. Pin function

No.	Symbol	I/O	Function	No.	Symbol	I/O	Function
1	CVBS/Cb/B1	O	Analog composite drive signal (+)	33	SO	-	Non connect
2	$\overline{\text{CVBS/Cb/B1}}$	O	Analog composite drive signal (-)	34	SDA/SI	I	SPI Mode : Serial data input
3	CVBS/Cb/B1Vdd	-	Power supply for CVBS/Cb/B DAC1	35	SCL/SCK	I	Serial clock input
4	Y/G1	O	Analog brightness signal/G drive signal (+)	36	SEL	I	Power supply for serial data,chip select,digital
5	$\overline{\text{Y/G1}}$	O	Analog brightness signal/G drive signal (-)	37	DVdd	--	Power supply for digital circuit
6	Y/G1Vdd	-	Power supply for Y/G DAC	38	DVss	--	Digital ground
7	C/Cr/R1	O	Analog chroma signal (+)	39	DVIN7	I/O	Y data input / test data I/O
8	$\overline{\text{C/Cr/R1}}$	O	Analog chroma signal (-)	40	DVIN6	I/O	Y data input / test data I/O
9	C/Cr/R1Vdd	-	Power supply for C/Cr/RDAC	41	DVIN5	I/O	Y data input / test data I/O
10	DAVss	-	Connect to ground for DAC	42	DVIN4	I/O	Y data input / test data I/O
11	TBIAS1	O	Standard BIAS for DAC1	43	DVIN3	I/O	Y data input / test data I/O
12	Vref1	-	Standard voltage for DAC1	44	DVIN2	I/O	Y data input / test data I/O
13	DAVdd	-	Power supply for DAC	45	DVIN1	I/O	Y data input / test data I/O
14	Vref2	-	Standard voltage for DAC2	46	DVIN0	I/O	Y data input / test data I/O
15	TBIAS2	O	Standard BIAS for DAC2	47	TVIN	I	VIDEO mute on Reset(0:nomal, 1:mute)
16	NC	-	Non connect	48	EXT	I/O	Frame output / VBI information input
17	CVBS/Cb/B2	O	Analog composite drive signal (+)	49	F/Vsyac	I/O	Frame / Vertical, synchronous I/O
18	$\overline{\text{CVBS/Cb/B2}}$	O	Analog composite drive signal (-)	50	Chsyac	I/O	The horizontal, synchronous I/O
19	CVBS/Cb/B2Vdd	-	Power supply for CVBS/Cb/B DAC2	51	DATST	I	Data input
20	Y/G2	O	Analog brightness signal/G drive signal (+)	52	TP-8	I/O	Multiplex data input
21	$\overline{\text{Y/G2}}$	O	Analog brightness signal/G drive signal (-)	53	TP7	I/O	Multiplex data input
22	Y/GVdd	-	Power supply for Y/G DAC	54	TP6	I/O	Multiplex data input
23	C/Cr/R2	O	Analog chroma signal (+)	55	TP5	I/O	Multiplex data input
24	$\overline{\text{C/Cr/R2}}$	O	Analog chroma signal (-)	56	DVss	-	Ground for digital circuit
25	C/Cr/R2Vdd	-	Power supply for C/Cr/RDAC2	57	DVdd	-	Power supply for digital circuit
26	ChipA	-	Chip address selection	58	TP4	I/O	Data input / Test data I/O
27	TEST	I	Connect to test pin	59	TP3	I/O	Data input / Test data I/O
28	DVdd	-	Digital ground	60	TP2	I/O	Data input / Test data I/O
29	CLOCK	I	Clock signal input (27MHz)	61	TP1	I/O	Data input / Test data I/O
30	DVss	-	Power supply for digital circuit	62	TP0	I/O	Data input / Test data I/O
31	Reset	I	Reset signal input L:ON	63	DLVdd	-	Power supply for D/A converter
32	PAL/NTSC	I	Selection NTSC/PAL NTSC:L PAL:H	64	DLVss	-	Ground for D/A converter

MN102L25GHW(IC401) : UNIT CPU

1. Pin layout

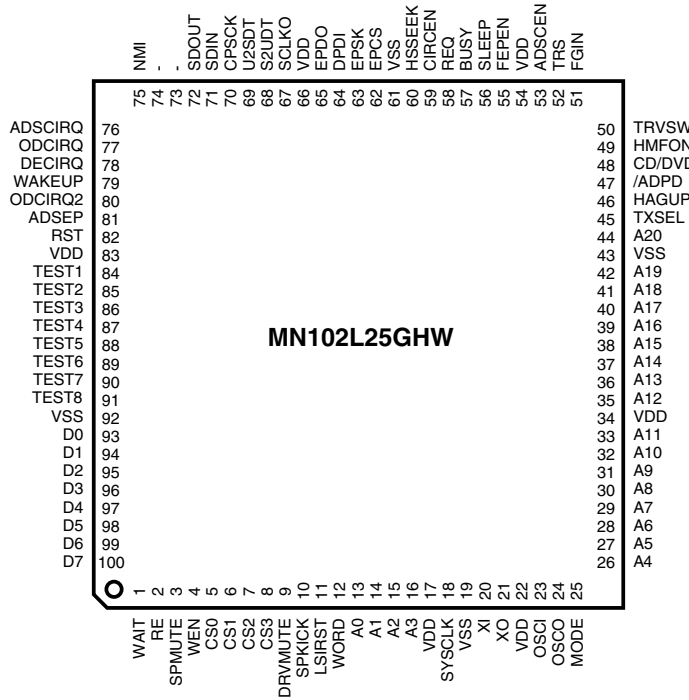

2. Pin function

Pin No.	Symbol	I/O	Function	Pin No.	Symbol	I/O	Function
1	WAIT	I	Micon wait signal input	51	FGIN	I	Photo input
2	RE	O	Read enable	52	TRS		
3	SPMUTE	O		53	ADSCEN	O	Serial enable signal for ADSC
4	WEN	O	Write enable	54	VDD	-	Power supply
5	CS0	O	Non connect	55	FEPEN	O	Serial enable signal for FEP
6	CS1	O	Chip select for ODC	56	SLEEP	O	Standby signal for FEP
7	CS2	O	Chip select for ZIVA	57	BUSY	I	Communication busy
8	CS3	O	Chip select for outer ROM	58	REQ	O	Communication request
9	DRVMUTE	O	Driver mute	59	CIRCEN	O	CIRC command select
10	SPKICK	O	Non connect (Spin kick output)	60	HSSEEK	O	Seek select
11	LSIRST	O	LSI reset	61	VSS	-	GND
12	WORD	O	Bus selection input	62	EPCS	O	Chip select signal for EEPROM
13	A0	O	Address bus 0 for CPU	63	EPSK	O	Clock signal for EEPROM
14	A1	O	Address bus 1 for CPU	64	DPDI	I	Input data for EEPROM
15	A2	O	Address bus 2 for CPU	65	EPDO	O	Output data for EEPROM
16	A3	O	Address bus 3 for CPU	66	VDD	-	Power supply
17	VDD	-	Power supply	67	SCLKO	I	Communication clock
18	SYSCLK	O	System clock signal output	68	S2UDT	I	Communication input data
19	VSS	-	GND	69	U2SDT	O	Communication output data
20	XI	-	Non connect (Connect to VSS)	70	CPSCK	O	Clock for ADSC serial
21	XO	-	Non connect	71	SDIN	I	ADSC serial data input
22	VDD	-	Power supply	72	SDOUT	O	ADSC serial data output
23	OSCI	I	Clock signal input (13.5MHz)	73	-	-	Non connect
24	OSCO	O	Clock signal output (13.5MHz)	74	-	-	Non connect
25	MODE	I	CPU Mode selection input	75	NMI	-	Non connect
26	A4	O	Address bus 4 for CPU	76	ADSCIRQ	I	Interrupt input of ADSC
27	A5	O	Address bus 5 for CPU	77	ODCIRQ	I	Interrupt input of ODC
28	A6	O	Address bus 6 for CPU	78	DECIRQ	I	Interrupt input of ZIVA
29	A7	O	Address bus 7 for CPU	79	WAKEUP	O	Non connect
30	A8	O	Address bus 8 for CPU	80	ODCIRQ2	I	
31	A9	O	Address bus 9 for CPU	81	ADSEP	I	Address data selection input
32	A10	O	Address bus 10 for CPU	82	RST	I	Reset input
33	A11	O	Address bus 11 for CPU	83	VDD	-	Power supply
34	VDD	-	Power supply	84	TEST1	I	Test signal 1 input
35	A12	O	Address bus 12 for CPU	85	TEST2	I	Test signal 2 input
36	A13	O	Address bus 13 for CPU	86	TEST3	I	Test signal 3 input
37	A14	O	Address bus 14 for CPU	87	TEST4	I	Test signal 4 input
38	A15	O	Address bus 15 for CPU	88	TEST5	I	Test signal 5 input
39	A16	O	Address bus 16 for CPU	89	TEST6	I	Test signal 6 input
40	A17	O	Address bus 17 for CPU	90	TEST7	I	Test signal 7 input
41	A18	O	Address bus 18 for CPU	91	TEST8	I	Test signal 8 input
42	A19	O	Address bus 19 for CPU	92	VSS	-	GND
43	VSS	-	GND	93	D0	I/O	Data bus 0 of CPU
44	A20	O	Address bus 20 for CPU	94	D1	I/O	Data bus 1 of CPU
45	TXSEL	O	TX select	95	D2	I/O	Data bus 2 of CPU
46	HAGUP	O		96	D3	I/O	Data bus 3 of CPU
47	/ADPD			97	D4	I/O	Data bus 4 of CPU
48	CD/DVD	O		98	D5	I/O	Data bus 5 of CPU
49	HMFON			99	D6	I/O	Data bus 6 of CPU
50	TRVSW	I	Detection switch of traverse inside	100	D7	I/O	Data bus 7 of CPU

MN103S13BDA(IC301) : Optical disc controller

1. Pin layout

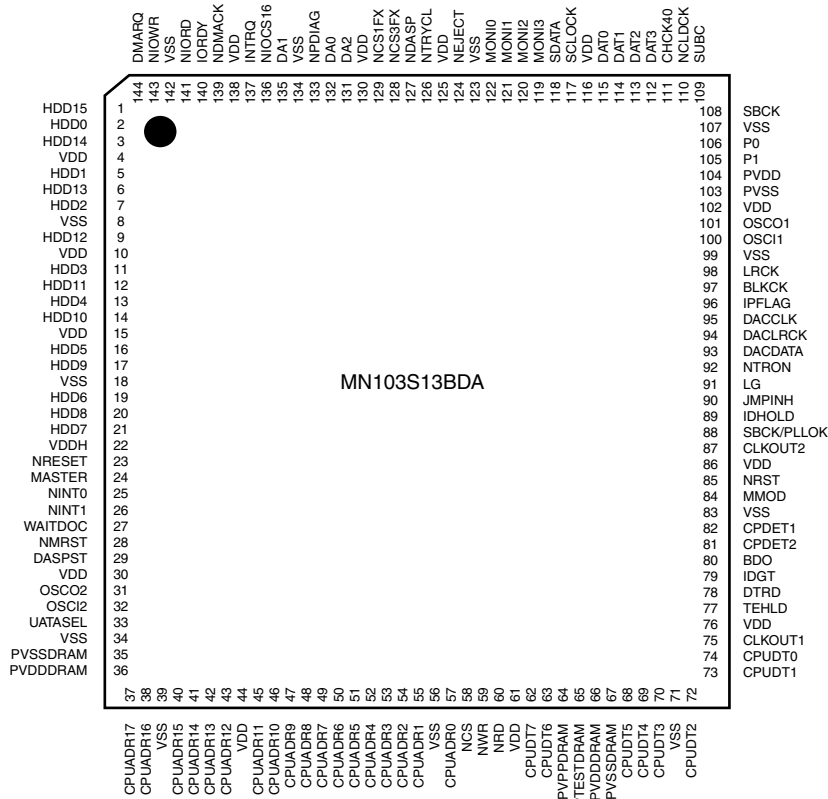

2. Block diagram

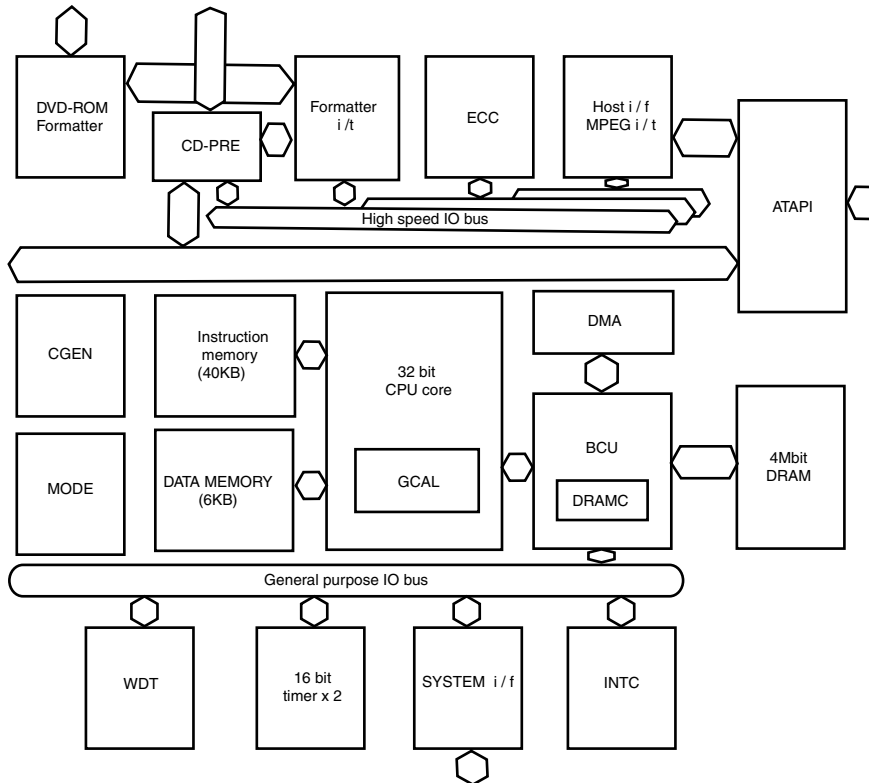

3.Pin function

Pin No.	Symbol	I/O	Function	Pin No.	Symbol	I/O	Function
1	HDD15	I/O	ATAPI data	73	CPUDT1	I/O	System control data
2	HDD0	I/O	ATAPI data	74	CPUDT0	I/O	System control data
3	HDD14	I/O	ATAPI data	75	CLKOUT1	O	16.9/11.2/8.45MHz clock
4	VDD	-	Power supply (3V)	76	VDD	-	Power supply (3V)
5	HDD1	I/O	ATAPI data	77	TEHLD	O	Mirror gate (Connect with TP141)
6	HDD13	I/O	ATAPI data	78	DTRD	O	Frequency control switch for data (Connect with TP304)
7	HDD2	I/O	ATAPI data	79	IDGT	O	Part CAPA switch
8	VSS	-	GND	80	BDO	I	RF dropout / BCA data
9	HDD12	I/O	ATAPI data	81	CPDET2	I	Outer side CAPA detection
10	VDD	-	Power supply (2.7V)	82	CPDET1	I	Inner side CAPA detection
11	HDD3	I/O	ATAPI data	83	VSS	-	GND
12	HDD11	I/O	ATAPI data	84	MMOD	I	Connect with VSS
13	HDD4	I/O	ATAPI data	85	NRST	I	System reset
14	HDD10	I/O	ATAPI data	86	VDD	-	Power supply (3V)
15	VDD	-	Power supply (3V)	87	CLKOUT2	O	16.9MHz clock
16	HDD5	I/O	ATAPI data	88	SBCK/PLLOK	O	Frame mark detection
17	HDD9	I/O	ATAPI data	89	IDOHOLD	O	ID gate for holding tracking
18	VSS	-	GND	90	JMPINH	O	Jump prohibition
19	HDD6	I/O	ATAPI data	91	LG	O	Land / group switch
20	HDD8	I/O	ATAPI data	92	NTRON	I	Tracking ON
21	HDD7	I/O	ATAPI data	93	DACDATA	O	Serial output
22	VDDH			94	DACLRCK	O	L and R identification output
23	NRESET	I	ATAPI reset	95	DACCLK	I	Clock for serial output
24	MASTER	I/O	ATAPI master / slave selection	96	IPFLAG	I	IP flag input
25	NINT0	O	System control interruption 0	97	BLKCK	I	Clock for sub-code and block input
26	NINT1	O	System control interruption 1	98	LRCK	I	L and R identification signal output
27	WAITDOC	O	System control wait control	99	VSS	-	GND
28	NMRST	O	System control reset (Connect with TP302)	100	OSCI1	I	16.9MHz oscillation
29	DASPST	I	DASP signal initializing	101	OSCO1	O	16.9MHz oscillation
30	VDD	-	Power supply (3V)	102	VDD	-	Power supply (3V)
31	OSCO2	O	Not used (Connect with TP140)	103	PVSS	-	GND
32	OSCI2	I	Not used (Connect with TP303)	104	PVDD	-	Power supply (3V)
33	UATASEL	I	VSS connection	105	P1	I/O	Terminal MASTER polarity switch input
34	VSS	-	GND	106	P0	I/O	CIRC-RAM OVER/UNDER Interruption signal input
35	PVSSDRAM		VSS connection	107	VSS	-	GND
36	PVDDDRAM		Connect with 2.7V VDD	108	SBCK	O	Sub-code and Clock output for serial input
37	CPUADR17	I	System control address	109	SUBC	I	Sub-code and serial input
38	CPUADR18	I	System control address	110	NCLDCK	I	Sub-code and Frame clock input
39	VSS	-	GND	111	CHCK40	I	Read clock to DAT3-0 (Output of dividing frequency four from ADSC)
40	CPUADR15	I	System control address	112	DAT3	I	Read data from DISC (Parallel output from ADSC)
41	CPUADR14	I	System control address	113	DAT2	I	Read data from DISC (Parallel output from ADSC)
42	CPUADR13	I	System control address	114	DAT1	I	Read data from DISC (Parallel output from ADSC)
43	CPUADR12	I	System control address	115	DAT0	I	Read data from DISC (Parallel output from ADSC)
44	VDD	-	Power supply (2.7V)	116	VDD	-	Power supply (3V)
45	CPUADR11	I	System control address	117	SCLOCK	I/O	Debugging serial clock (270 Ω pull up)
46	CPUADR10	I	System control address	118	SDATA	I/O	Debugging serial data (270 Ω pull up)
47	CPUADR9	I	System control address	119	MONI3	O	Internal goods title monitor (Connect to TP150)
48	CPUADR8	I	System control address	120	MONI2	O	Internal goods title monitor (Connect to TP151)
49	CPUADR7	I	System control address	121	MONI1	O	Internal goods title monitor (Connect to TP152)
50	CPUADR6	I	System control address	122	MONI0	O	Internal goods title monitor (Connect to TP153)
51	CPUADR5	I	System control address	123	VSS	-	GND
52	CPUADR4	I	System control address	124	NEJECT	I	Eject detection
53	CPUADR3	I	System control address	125	VDD	-	Power supply (2.7V)
54	CPUADR2	I	System control address	126	NTRYCL	I	Tray close detection
55	CPUADR1	I	System control address	127	NDASP	I/O	ATAPI Drive active/Slave connection I/O
56	VSS	-	GND	128	NCS3FX	I	Not used (ATAPI host chip selection)
57	CPUADR0	I	System control address	129	NCS1FX	I	Not used (ATAPI host chip selection)
58	NCS	I	System control chip selection	130	VDD	-	Power supply (3V)
59	NWR	I	System control write	131	DA2	I/O	ATAPI host address
60	NRD	I	System control read	132	DA0	I/O	Not used (ATAPI host address)
61	VDD	-	Power supply (3V)	133	NPDIAG	I/O	ATAPI slave/master diagnosis input
62	CPUDT7	I/O	System control data	134	VSS	-	GND
63	CPUDT6	I/O	System control data	135	DA1	I/O	Not used (ATAPI host address)
64	PVPPDRAM	O	Connect with VSS	136	NIOCS16	O	ATAPI output for selecting width of host data bus
65	PTESTDRAM	I	Connect with VSS	137	INTRQ	O	ATAPI host interruption output
66	PVDDDRAM		Connect with VDD (2.7V)	138	VDD	-	Power supply (3V)
67	PVSSDRAM		Connect with VSS	139	NDMACK	I	Not used (ATAPI host DMA response)
68	CPUDT5	I/O	System control data	140	IORDY	O	ATAPI host ready output (Connect to TP157)
69	CPUDT4	I/O	System control data	141	NIORD	I	Not used (ATAPI host read)
70	CPUDT3	I/O	System control data	142	VSS	-	GND
71	VSS	-	GND	143	NIOWR	I/O	ATAPI host writes
72	CPUDT2	I/O	System control data	144	DMARQ	O	ATAPI host DMA demand (Connect to TP159)

MN67706ZY(IC201) : ADSC

1.Pin layout

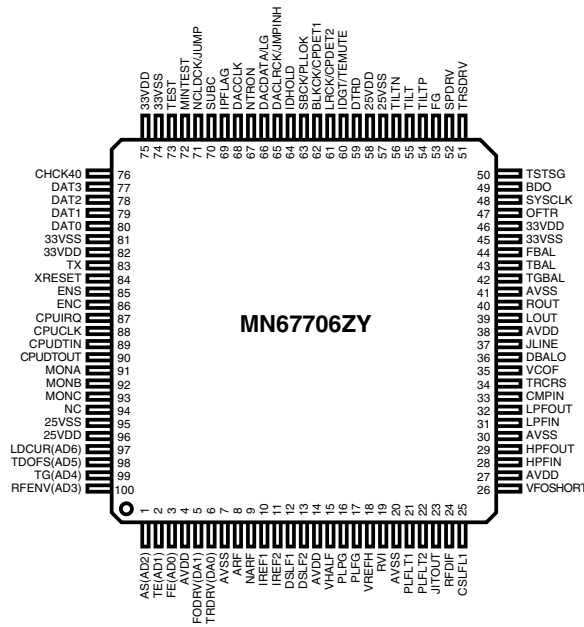

2.Pin function

Pin No.	Symbol	I/O	Function	Pin No.	Symbol	I/O	Function
1	AS(AD2)	I	AS : All added signal (FEP)	51	TRSDRV	O	Traverse drive (DRVIC)
2	TE(AD1)	I	Tracking error (FEP)	52	SPDRV	O	Spindle drive output (DRVIC)
3	FE(AD0)	I	Focus error (FEP)	53	FG	I	FG signal input (spindle motor driver)
4	AVDD	-	Power supply for analog circuit (3.3V)	54	TILTP	O	Connect with TP205
5	FODRV(DA1)	O	Focus drive (DRVIC)	55	TILT	O	Connect with TP206
6	TRDRV(DA0)	O	Tracking drive (DRVIC)	56	TILT	O	Connect with TP207
7	AVSS	-	Ground for analog circuit	57	25VSS	-	For internal core GND
8	ARF	I	Equalized RF+(FEP)	58	25VDD	-	Power supply for internal core (2.5V)
9	NARF	I	Equalized RF-(FEP)	59	DTRD	I	Data read control signal (ODC)
10	IREF1	I	Reference power supply 1 for DBAL	60	IDGT/TEMUTE	I	Pull down for GND
11	IREF2	I	Reference power supply 2 for DBAL	61	LRCK/CPDET2	O	LR channel data strobe (ODC)/
12	DSLF1	I/O	Capacitor 1 for DSL	62	BLKCK/CPDET1	O	CD sub code synchronize signal (ODC)/
13	DSLF2	I/O	Capacitor 2 for DSL	63	SBCK/PLLOCK	I	CD sub-code data shift clock (ODC)/SYNCC detection
14	AVDD	-	Power supply for analog circuit (3.3V)	64	IBHOLD	I	Pull down for GND
15	VHALF	I	Reference voltage 1.65±0.1V(FEP)	65	DACLRCK/JMPINH	I	1 bit DAC-LR channel data strobe (ODC)/
16	PLPG	-	Not used	66	DACDATA/LG	I	CD1 bit DAC channel data (ODC)
17	PLFG	-	Not used	67	NTRON	O	L:tracking ON (ODC)
18	VREFH	I	Reference voltage 2.2V±0.1V(FEP)	68	DACCLK	O	1 bit DAC channel data shift clock (ODC)
19	RVI	I/O	VREFH reference power supply for resistor	69	IPFLAG	O	CIRC error flag (ODC)
20	AVSS	-	Ground for analog circuit	70	SUBC	O	CD sub code (ODC)
21	PLFLT1	O	Capacitor 1 for PLL	71	NCLDCK/JUMP	O	CD sub code data frame clock (ODC)/DVD JUMP signal (ODC)
22	PLFLT2	O	Capacitor 2 for PLL	72	MINTEST	I	Connects with DVSS (for MINTEST)
23	JITOUT	I/O	Detection signal output of jitter	73	TEST	I	Connects with DVSS (for TEST)
24	RFDIF	I	Not used	74	33VSS	-	For I/O GND
25	CSLFL1	I/O	Pull up for VHALF	75	33VDD	-	Power supply for I/O (3.3V)
26	VFOSHORT	O	VFO short output	76	CHCK40	O	For SRDATA clock (ODC)
27	AVDD	-	Power supply for analog circuit (3.3V)	77	DAT3	O	SRDATA3(ODC)
28	HPFIN	I	Pull up for VHALF	78	DAT2	O	SRDATA2(ODC)
29	HPFOUT	O	Connect with TP208	79	DAT1	O	SRDATA1(ODC)
30	AVSS	-	Ground for analog circuit	80	DAT0	O	SRDATA0(ODC)
31	LPFIN	I	Pull up for VHALF	81	33VSS	-	For I/O GND
32	LPFOUT	O	Not used	82	33VDD	-	Power supply for I/O (3.3V)
33	CMPIN	I	Connect with TP210	83	TX	O	Digital audio interface
34	TRCRS	I	Track crossing signal (FEP)	84	XRESET	I	Reset L : Reset
35	VCOF	I/O	JFVCO control voltage	85	ENS	I	Servo DSC sereal I/F chip select (SYSCON)
36	DBALO	O	DSL balance adjustment output	86	ENC	I	CIRC sereal I/F chip select (SYSCON)
37	JLINE	O	J-line preset output (FEP)	87	CUIRQ	O	Interrupt request to silicon (SYSCON)
38	AVDD	-	Power supply for analog circuit (3.3V)	88	CPUCLK	I	Silicon cereal I/F clock (SYSCON)
39	LOUT	O	Connect with TP203 (analog audio L out)	89	CPUDTIN	I	Silicon cereal I/F data input (SYSCON)
40	ROUT	O	Connect with TP204 (analog audio R out)	90	CPUDTOUT	O	Silicon cereal I/F data output (SYSCON)
41	AVSS	-	Ground for analog circuit	91	MONA	O	Monitor terminal A (connect with TP226)
42	TGBAL	O	Tangential balance (FEP)	92	MONB	O	Monitor terminal B (connect with TP225)
43	TBAL	O	Tracking balance (FEP)	93	MONC	O	Monitor terminal C (connect with TP224)
44	FBAL	O	Focus balance (FEP)	94	NC	O	Not used (connect with TP211)
45	33VSS	-	For I/O GND	95	25VSS	-	For internal core GND
46	33VDD	-	Power supply for I/O (3.3V)	96	25VDD	-	Power supply for internal core (2.5V)
47	OFTR	I	Off-track error signal (FEP)	97	LDCUR(AD6)	I	
48	SYSCLK	I	16.9344MHz system clock input (ODC)	98	TDOFS(AD5)	I	
49	BDO	I	BDO + BCA (FEP)	99	TG(AD4)	I	Tangential Phase difference (FEP)
50	TSTSG	O	Self calibration signal (FEP)	100	RFENV(AD3)	I	RFENV (FEP)

MSM531622F91G-X(IC402) : 1M x 16Bit/2M x 8Bit change enable ROM

1.Pin layout

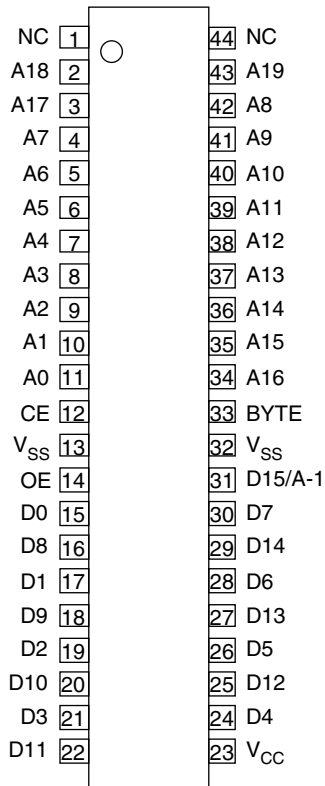

44 pin SOP

3.Pin function

Symbol	Function
D15/A-1	Address input (For 8bit output)
A0~A19	Address input
D0~D15	Data output
\overline{CE}	Chip enable
\overline{OE}	Chip enable
\overline{BYTE}	Output 16/8bit select L : 8bit output + H : 16bit output
V_{CC}, V_{SS}	Power supply
NC	No connection

2.Block diagram

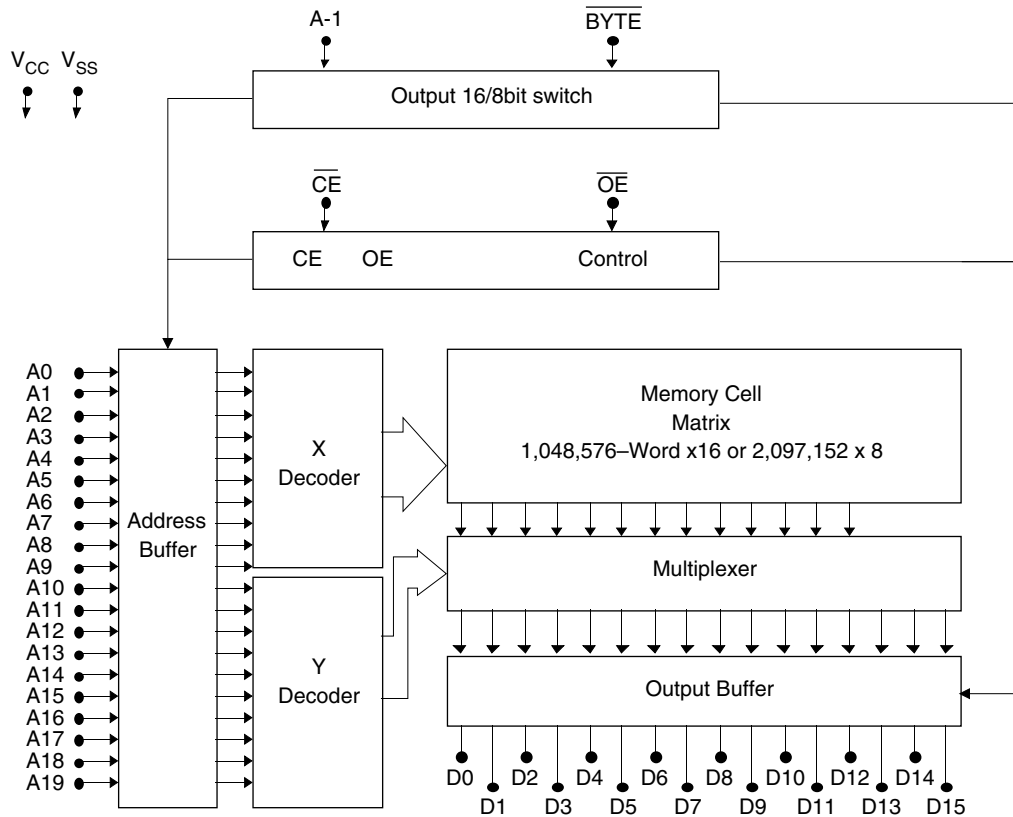

■ RN5RZ33BA-X(IC1, IC102) : High cycle module

1.Terminal layout

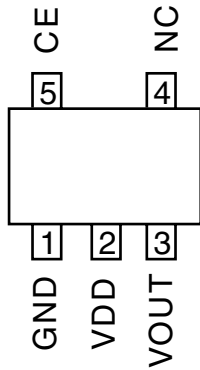

2.Block diagram

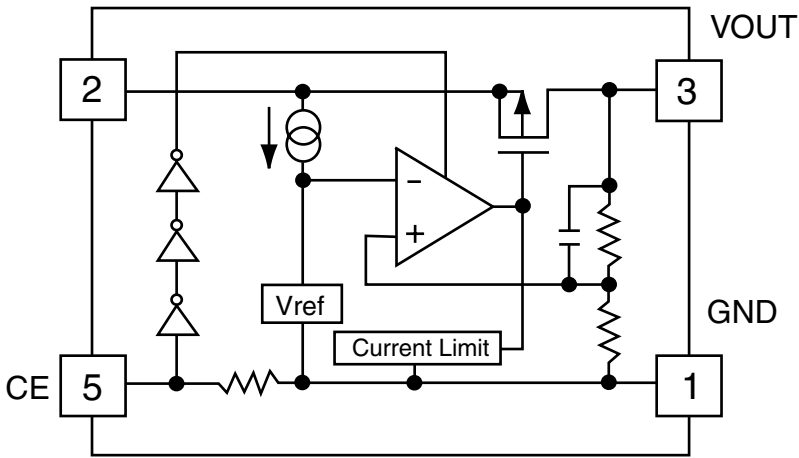

3.Pin function

Pin No.	Pin name	Function
1	GND	Ground terminal
2	VDD	Input terminal
3	VOUT	Output terminal
4	NC	No connection
5	CE	Chip enable terminal

■ STK404-130(IC105) : Power amp

1. Terminal layout

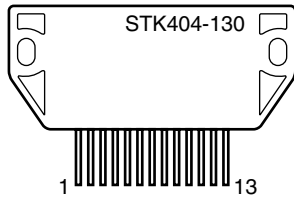

2. Block diagram

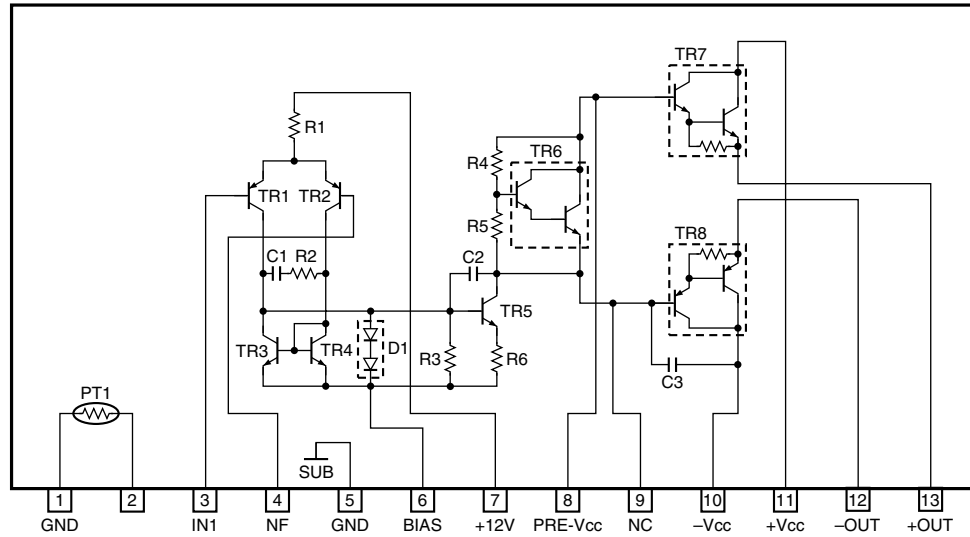

■ STK402-230(IC107) : Power amp

1. Terminal layout

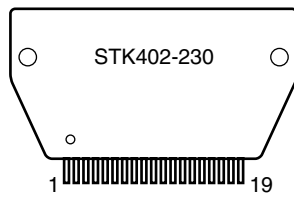

2. Block diagram

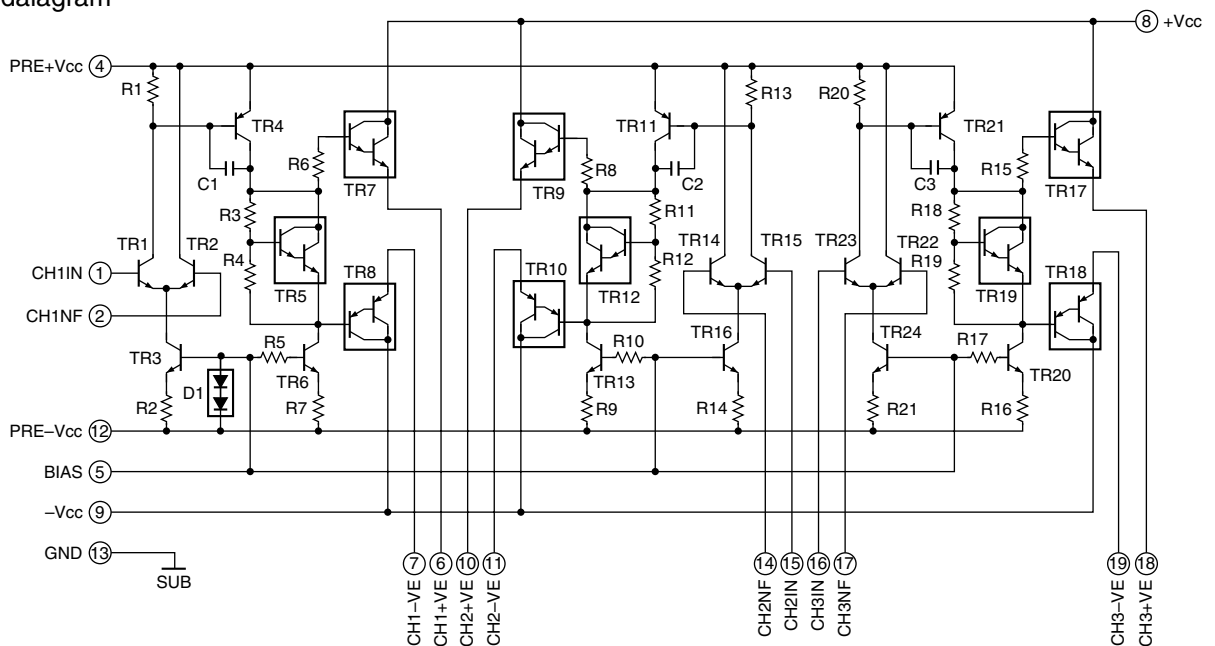

■ **TC74VHC00FT-X(IC322,IC503)**
: Write timing control

1.Pin layout /Block diagram

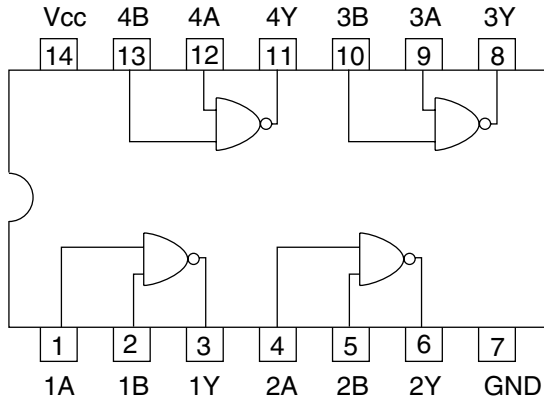

■ **TC7WH74FU-X(IC321)** : Clock buffer

1.Terminal layout

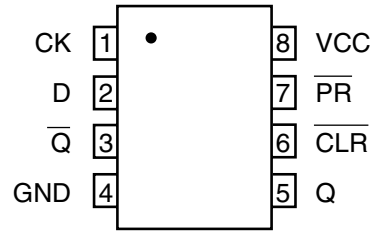

■ **TC7SH32FU-X(IC312)**
: Timing control

1.Terminal layout

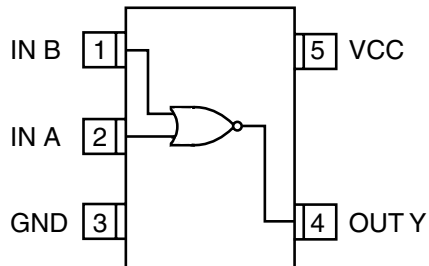

■ **TC7SH08FU-X(IC311)** : Timing control

1.Terminal layout

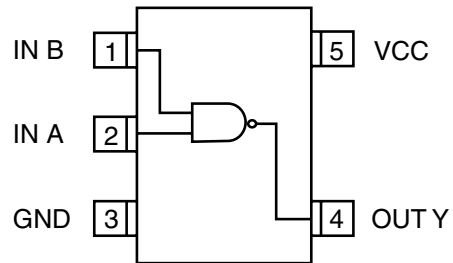

■ TC7W125FU-X(IC202) : Buffer

1. Terminal layout

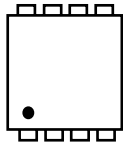

2. Block diagram

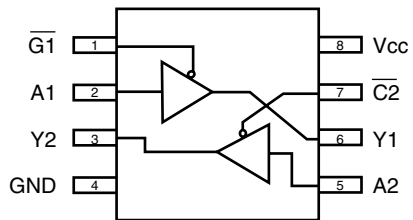

■ BA15218N(IC104,IC108,IC109,IC110) : OP AMP

1. Pin layout / Block diagram

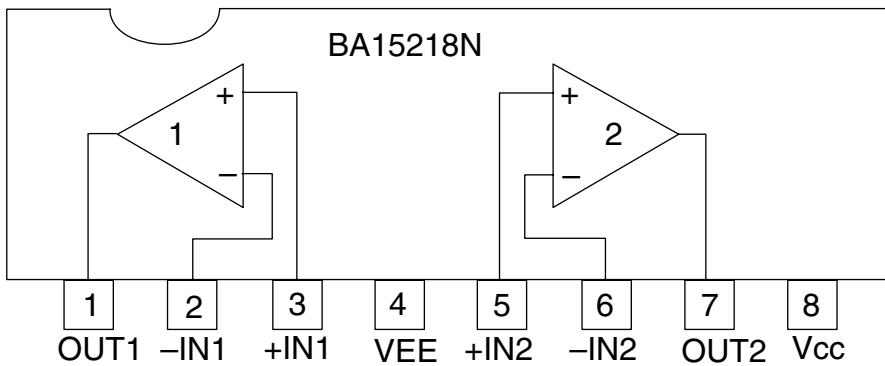

■ ZIVA3-PE0 (IC501) : AV Decoder

1. Terminal Description

ZIVA3-PE0 (1/5)

Pin No.	Symbol	I/O	Function
1	PIO0	I/O	Programmable I/O pin, which enters input mode after resetting.
2	HDATA0	I/O	8-bit, bi-directional host data bus. Write data in decoder Code FIFO via HDATA. The 32-bit word MSB is written first. The host reads and writes the internal register of the decoder and local SRAM via HDATA.
3	HDATA1		
4	HDATA2		
5	VDD-3.3		
6	HDATA3	I/O	8-bit, bi-directional host data bus. Writes data in decoder Code FIFO via HDATA. The 32-bit word MSB is written first. The host reads and writes the internal register of the decoder and local SRAM via HDATA.
7	VSS	-	Core logic and I/O signal grounding.
8	HDATA4	I/O	8-bit, bi-directional host data bus. Write data in decoder Code FIFO via HDATA. The 32-bit word MSB is written first. The host reads and writes the internal register of the decoder and local SRAM via HDATA.
9	HDATA5		
10	HDATA6		
11	HDATA7		
12	VDD-2.5		
13	RESET	I	Hardware reset. An external device expresses RESET (Active Low) to execute hardware resetting of the decoder. RESET is expressed for at least 20 ms to guarantee optimum initialization to occur after power has stabilized.
14	VSS	-	Core logic and I/O signal grounding.
15	WAIT/DACK	O	Transfer incomplete/data acknowledgement, which is an Active Low signal indicating that transfer started by the host is not completed. WAIT is expressed after negative going edge of CS, and expressed again when the decoder is ready for completing the transfer cycle. As the signal for opening the drain should be pulled up from 1 V to 3.3 V, it is driven at high speed for 10 ns before the tri-state condition is entered.
16	INT	O	Host interrupt. As the signal for opening the drain should be pulled up from 4.7 V to 3.3 V, it is driven at high speed for 10 ns before the tri-state condition is entered.
17	VDD-3.3	-	3.3 V supply voltage for I/O signals.
18	NC	O	No connection.
19	VSS	-	Core logic and I/O signal grounding.
20	NC	O	No connection.
21	PIO11	I/O	Programmable I/O pins, which enter input mode. after resetting.
22	PIO12		
23	PIO13		
24	PIO14		
25	PIO15		
26	PIO16		
27	VDD-3.3	-	3.3 V supply voltage for I/O signals.
28	PIO17	I/O	Programmable I/O pin, which enters input mode after resetting.
29	VSS	-	Core logic and I/O signal grounding.
30	PIO18	I/O	Programmable I/O pin, which enters input mode after
31	PIO19	I/O	Programmable I/O pins, which enter output mode after resetting.
32	PIO20		
33	PIO21		
34	PIO22		
35	PIO23		
36	VDD-3.3	-	3.3 V supply voltage for I/O signals.
37	PIO24	I/O	Programmable I/O pin, which enters output mode after resetting.
38	VSS	-	Core logic and I/O signal grounding.
39	PIO25	I/O	Programmable I/O pin, which enters output mode after resetting.
40	VDD-2.5	-	2.5 V supply voltage for the core logic.
41	PIO26	I/O	Programmable I/O pin, which enters output mode after resetting.
42	VSS	-	Core logic and I/O signal grounding.

Pin No.	Symbol	I/O	Function
44	PIO28	I/O	Programmable I/O pins, which enter output mode after resetting.
45	PIO29		
46	PIO30		
47	VDD-3.3	-	3.3 V supply voltage for I/O signals.
48	PIO31	I/O	Programmable I/O pin, which enters output mode after resetting.
49	VSS	-	Core logic and I/O signal grounding.
50	NC	O	No connection.
51			
52	PIO1	I/O	Programmable I/O pin, which enters input mode after resetting.
53	MDATA15	I/O	Memory data.
54	MDATA0	I/O	Memory data.
55	VDD-3.3	-	3.3 V supply voltage for I/O signals.
56	MDATA14	I/O	Memory data.
57	VSS	-	Core logic and I/O signal grounding.
58	MDATA1	I/O	Memory data.
59	MDATA13		
60	MDATA2		
61	VDD-3.3	-	3.3 V supply voltage for I/O signals.
62	MDATA12	I/O	Memory data.
63	VSS	-	Core logic and I/O signal grounding.
64	MDATA3	I/O	Memory data.
65	VDD-2.5	-	2.5 V supply voltage for the core logic.
66	MDATA11	I/O	Memory data.
67	VSS	-	Core logic and I/O signal grounding
68	MDATA4	I/O	Memory data.
69	VDD-3.3	-	3.3 V supply voltage for I/O signals.
70	MDATA10	I/O	Memory data.
71	VSS	-	Core logic and I/O signal grounding.
72	MDATA5	I/O	Memory data.
73	MDATA9		
74	MDATA6		
75	VDD-3.3	-	3.3 V supply voltage for I/O signals.
76	MDATA8	I/O	Memory data.
77	VSS	-	Core logic and I/O signal grounding.
78	MDATA7	I/O	Memory data.
79	LDQM	O	SDRAM LDQM.
80	UDQM	O	SDRAM UDQM.
81	VDD-3.3	-	3.3 V supply voltage for I/O signals.
82	$\overline{\text{MWE}}$	O	SDRAM write enable. The decoder expresses Active Low to request write operation of the SDRAM array.
83	VSS	-	Core logic and I/O signal grounding.
84	SD-CLK	O	SDRAM system clock.
85	$\overline{\text{SD-CAS}}$	O	Active Low, SDRAM column address.
86	$\overline{\text{SD-RAS}}$	O	Active Low, SDRAM row address.
87	VDD-3.3	-	3.3 V supply voltage for I/O signals.
88	$\overline{\text{SD-CS1}}$	O	Active Low SDRAM bank selection.
89	VSS	-	Core logic and I/O signal grounding.
90	SD-CS0	O	Active Low SDRAM bank selection.
91	VDD-2.5	-	2.5 V supply voltage for the core logic.
92	NC	O	No connection.
93	VSS	-	Core logic and I/O signal grounding.
94	NC	O	No connection.
95	VDD-3.3	-	3.3 V supply voltage for I/O signals.
96	MADDR9	O	Memory address.
97	VSS	-	Core logic and I/O signal grounding.
98	MADDR11	O	Memory address.

Pin No.	Symbol	I/O	Function
99	MADDR8	O	Memory address.
100	MADDR10		
101	VDD-3.3	-	3.3 V supply voltage for I/O signals.
102	MADDR7	O	Memory address.
103	VSS	-	Core logic and I/O signal grounding.
104	MADDR0	O	Memory address.
105	MADDR6		
106	MADDR1		
107	VDD-3.3	-	3.3 V supply voltage for I/O signals.
108	MADDR5	O	Memory address.
109	VSS	-	Core logic and I/O signal grounding.
110	MADDR2	O	Memory address.
111	MADDR4		
112	MADDR3		
113	VDD-3.3	-	3.3 V supply voltage for I/O signals.
114	NC	O	No connection.
115	VSS	-	Core logic and I/O signal grounding.
116	NC	O	No connection.
117	VDD-2.5	-	2.5 V supply voltage for the core logic.
118	NC	O	No connection.
119	VSS	-	Core logic and I/O signal grounding.
120	NC	O	No connection.
121			
122			
123	VDD-3.3	-	3.3 V supply voltage for I/O signals.
124	NC	O	No connection.
125	VSS	-	Core logic and I/O signal grounding.
126	NC	O	No connection.
127			
128	RESERVED	O	The signal for opening the drain should be pulled up from 4.7 V to 3.3 V.
129	PIO2	I/O	Programmable I/O pin. Enters input mode after resetting.
130	NC	O	No connection.
131	RESERVED	I	Coupled with VSS or VDD-3.3.
132			
133	PIO3	I/O	Programmable I/O pin, which enters input mode after resetting
134	VDD-3.3	-	3.3 V supply voltage for I/O signals.
135	RESERVED	I	Coupled with VSS or VDD-3.3.
136	VSS	-	Core logic and I/O signal grounding.
137	RESERVED	I	Coupled with VSS or VDD-3.3.
138	PIO4	I/O	Programmable I/O pin, which enters input mode after resetting.
139	RESERVED	I	Coupled with VSS or VDD-3.3.
140			
141	PIO5	I/O	Programmable I/O pin, which enters input mode after resetting.
142	VDATA0	O	Video data bus for byte-serial CbYCrY data in sync with VCLK. In power up, the decoder does not drive VDATA. In boot-up, the decoder uses the configuration parameters for drive or tri-state VDATA.
143	VDATA1		
144	VDD-2.5	-	2.5 V supply voltage for the core logic.
145	VDATA2	O	Video data bus for byte-serial CbYCrY data in sync with VCLK. In power up, the decoder does not drive VDATA. In boot-up, the decoder uses the configuration parameters for drive or tri-state VDATA.
146	VSS	-	Core logic and I/O signal grounding.
147	PIO6	I/O	Programmable I/O pin, which enters input mode after resetting.
148	VDATA3	O	Video data bus for byte-serial CbYCrY data in sync with VCLK. In power up, the decoder does not drive VDATA. In boot-up, the decoder uses the configuration parameters for drive or tri-state VDATA.

Pin No.	Symbol	I/O	Function
149	VDD-3.3	-	3.3 V supply voltage for I/O signals.
150	VDATA4	O	Video data bus for byte-serial CbYCrY data. In power up, the decoder does not drive VDATA. In boot-up, the decoder uses the operation configuration parameters or tri-state VDATA.
151	VSS	-	Core logic and I/O signal grounding.
152	VDATA5	O	Video data bus for byte-serial CbYCrY data. In power up, the decoder does not drive VDATA. In boot-up, the decoder uses the operation configuration parameters or tri-state VDATA.
153	PIO7	I/O	Programmable I/O pin, which enters input mode after resetting.
154	VDATA6	O	Video data bus for byte-serial CbYCrY data. In power up, the decoder does not drive VDATA. In boot-up, the decoder uses the operation configuration parameters or tri-state VDATA.
155	VDATA7		
156	PIO8	I/O	Programmable I/O pin, which enters input mode after resetting.
157	HSYNC	I/O	Horizontal sync. After the negative-going edge of \overline{VSYNC} , the decoder starts pixel data output for the new horizontal line.
158	VSYNC	I/O	Vertical sync, which is bi-directional. After the negative-going edge of \overline{VSYNC} , the decoder outputs the highest border of the new field for the first SYNC. \overline{VSYNC} can receive either V sync or upper/lower field notification from an external source.
159	DA-IEC	O	ICE-1937 bitstream output or IEO-958 format PCM data output.
160	VDD-3.3	-	3.3 V supply voltage for I/O signals.
161	DA-DATA0	O	PCM data output in 8 channels. Serial audio sample relative to the DA-BCK clock.
162	VSS	-	Core logic and I/O signal grounding.
163	DA-DATA1	O	PCM data output in 8 channels. Serial audio sample relative to the DA-BCK clock.
164	DA-DATA2		
165	DA-DATA3		
166	DA-LRCK	O	PCM left/right clock. Identifies the channel for each audio sample. The polarity is programmable.
167	DA-BCK	O	PCM bit clock. Obtained by dividing DA-XCK by 8. DA-BCK takes a value of 48 or 32 times the sampling clock.
168	VDD-2.5	-	2.5 V supply voltage for the core logic.
169	DA-XCK	I/O	Audio master frequency clock, which is used to generate DA-BCK and DALRCK. DA-XCK takes a value of 384 or 256 times the sampling frequency.
170	VSS	-	Core logic and I/O signal grounding.
171	DAI-DATA	I	PCM input data with 2 channels. Serial audio sample relative to the DA-BCK clock.
172	DAI-LRCK	I	PCM input left/right clock.
173	DAI-BCK	I	PCM input bit clock.
174	PIO9	I/O	Programmable I/O pin, which enters input mode after resetting.
175	CLKSEL	I	Input selection: Internal = VDD. External = VSS.
176	A-VDD	-	3.3 V analog supply voltage.
177	VCLK	I	Video clock. Data is recorded at input.
178	SYSCLK	I	System clock. The decoder requires an external 27 MHz TTL oscillator. Same drive frequency as the VCK of 27 MHz.
179	A-VSS	-	Analog grounding of the PLL.
180	DVD-DATA0 /CD-DATA	I	Serial CD data. This pin is also used as a DVD compression data pin DVD-DATA0.
181	VDD-3.3	-	3.3 V supply voltage for I/O signals.
182	DVD-DATA1 /CD-LRCK	I	16-bit word sync with programmable polarity for the decoder (right channel High). This pin is also used as a DVD compression data pin DVD-DATA1.
183	VSS	-	Core logic and I/O signal grounding.
184	DVD-DATA2 /CD-BCK	I	CD bit clock. The decoder accepts multiple BCK rates. This pin is also used as a DVD compression data pin DVD-DATA2.
185	DVD-DATA3 /CD-C2PO	I	Performs High expression by indicating the damaged byte. The decoder holds the effective pixels in the last image until the next effective image is decoded. DVD compression data pin DVD-DATA3.

Pin No.	Symbol	I/O	Function
186	DVD-DATA7	I	DVD parallel compression data from the DVD DSP. When the DVD DSP transmits a 32-bit word, it should first describe the WSB. CDG-SDTA: CD+G (subcode) data, which indicates a serial subcode data input. CDG-VSFY: CD+G (subcode) frame sync, which indicates the start of a frame or a composite sync input. CDG-SOS1: CD+G (subcode) block sync, which indicates a block start sync input. CDG-SCLK: CD+G (subcode) clock, which indicates the input or output of the subcode data clock.
187	/CDG-SCLK		
188	DVD-DATA6		
189	/CDG-SOS1		
	DVD-DATA5 /CDG-VFSY DVD-DATA4 /CDG-SDATA		
190	PIO10	I/O	Programmable I/O pin, which enters the input mode after resetting.
191	VREQUEST	O	Video request. The decoder expresses VREQUEST to indicate that the video input buffer has available space. The polarity is programmable.
192	VSTROBE	I	Video strobe, which is a programmable, dual-mode pulse and either async or sync. In the async mode, the external source sends VSTROBE to indicate that it is ready for data transfer. In the sync mode, the signal becomes the VSTROBE clock data.
193	VDD-3.3	-	3.3 V supply voltage for I/O signals.
194	NC	O	No connection.
195	VSS	-	Core logic and I/O signal grounding.
196	V-DACK	I	Video data acknowledgement in the case of the sync mode. Expressed when the DVD data is valid. The polarity is programmable.
197	VDD-2.5	-	2.5 V supply voltage for the core logic.
198	RESERVED	I	Coupled with VSS or VDD-3.3.
199	VSS	-	Core logic and I/O signal grounding.
200	ERROR	I	Input data error. If the ERROR signal from the DSP is unusable, grounding should be performed.
201	HOST8SEL	I	Permanently coupled with VDD-3.3.
202	HADDR0	I	Host address bus. This 3-bit address bus selects one of the six hosts interface registers.
203	HADDR1		
204	HADDR2		
205	DTACKSEL	I	Coupled with High to select the $\overline{\text{WAIT}}$ signal or with Low to select the $\overline{\text{DTACK}}$ signal. (Motorola 68K mode)
206	$\overline{\text{CS}}$	I	Host chip selection. The host expresses CS to select the decoder for use in read/write. The read or write operation starts at the negative-going edge of this signal.
207	R/ $\overline{\text{W}}$	I	Performs strobe read/write in the M mode and strobe write in the I mode. The host expresses R/ $\overline{\text{W}}$ LOW to select write or LOW to select read.
208	$\overline{\text{RD}}$	I	Performs strobe read in the I mode. Should be kept HIGH in the M mode.

JVC

VICTOR COMPANY OF JAPAN, LIMITED

AUDIO & COMMUNICATION BUSINESS DIVISION

PERSONAL & MOBILE NETWORK B.U. 10-1, 1Chome, Ohwatari-machi, maebashi-city, 371-8543, Japan

Block diagrams

Overall block diagram

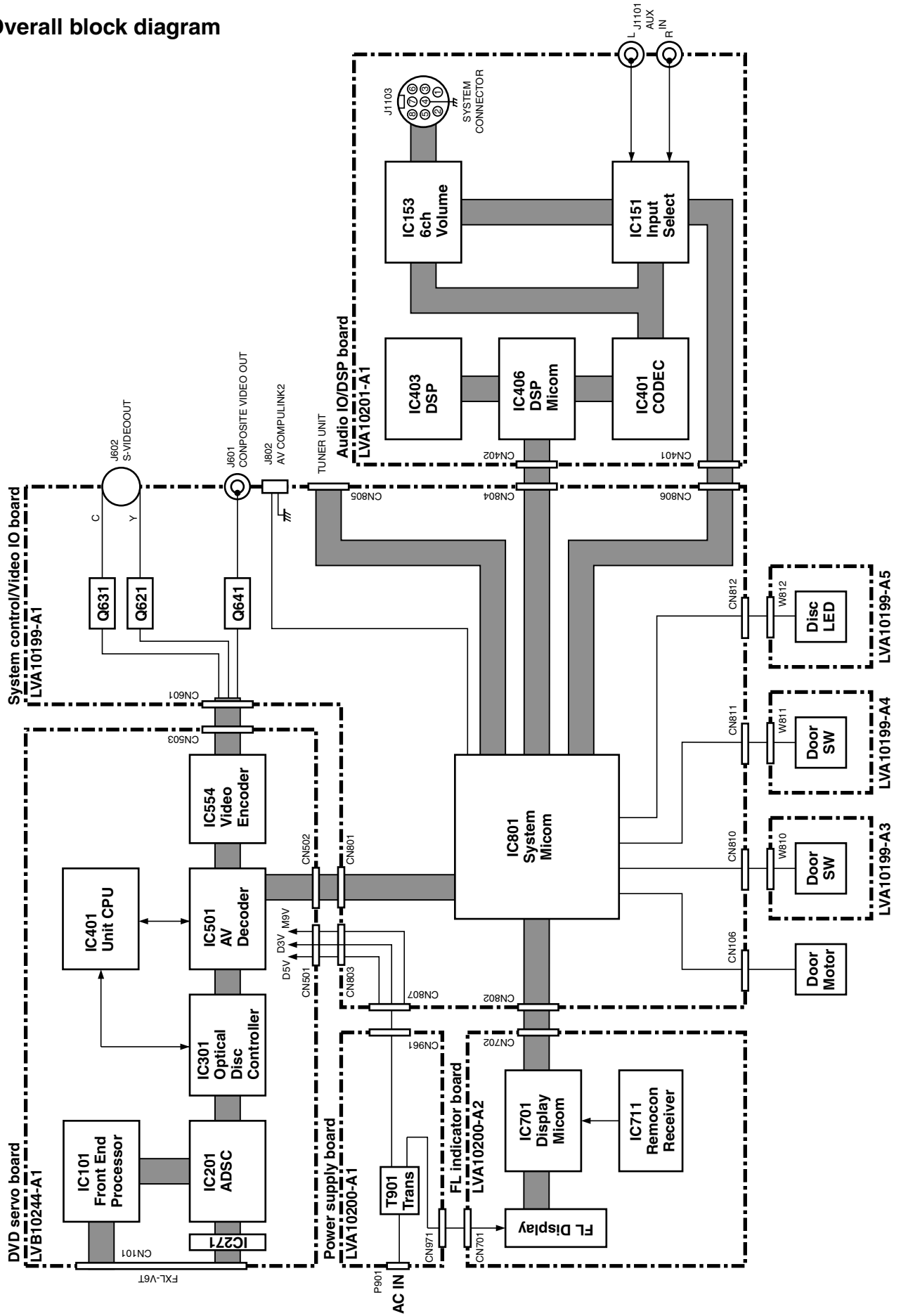

Overall block diagram

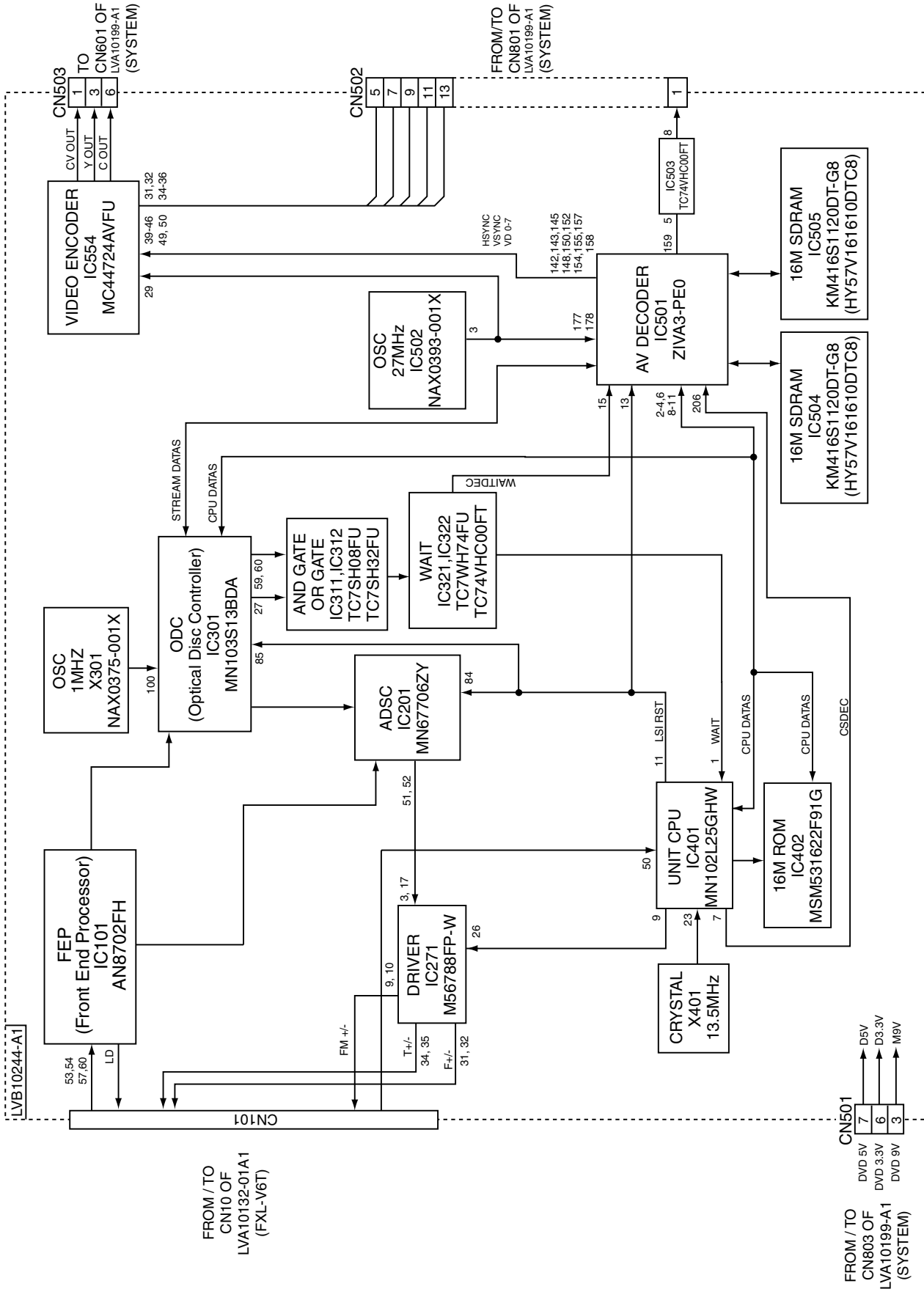

■ Block diagram (power supply section)

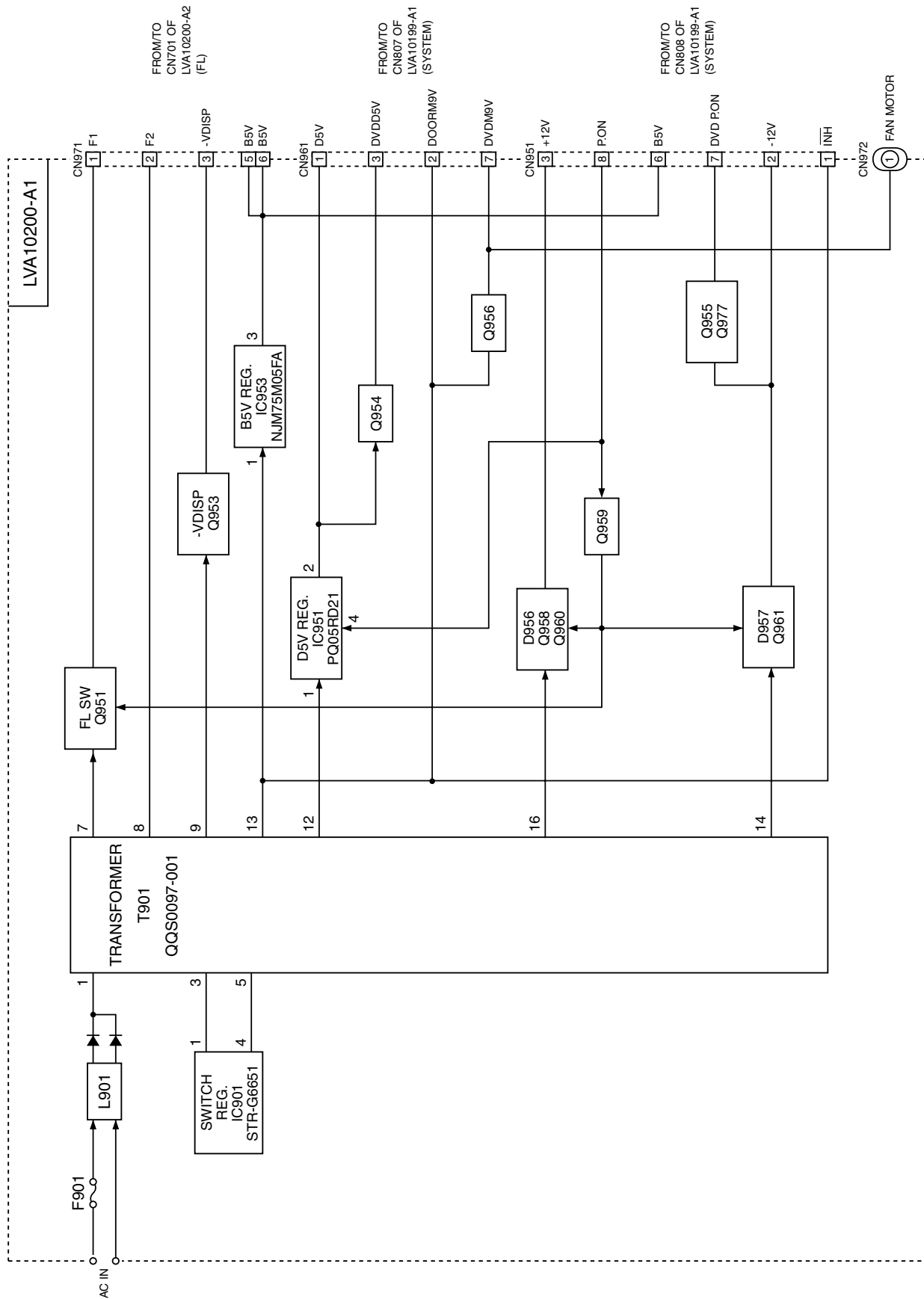

■ Block diagram (audio input/output section)

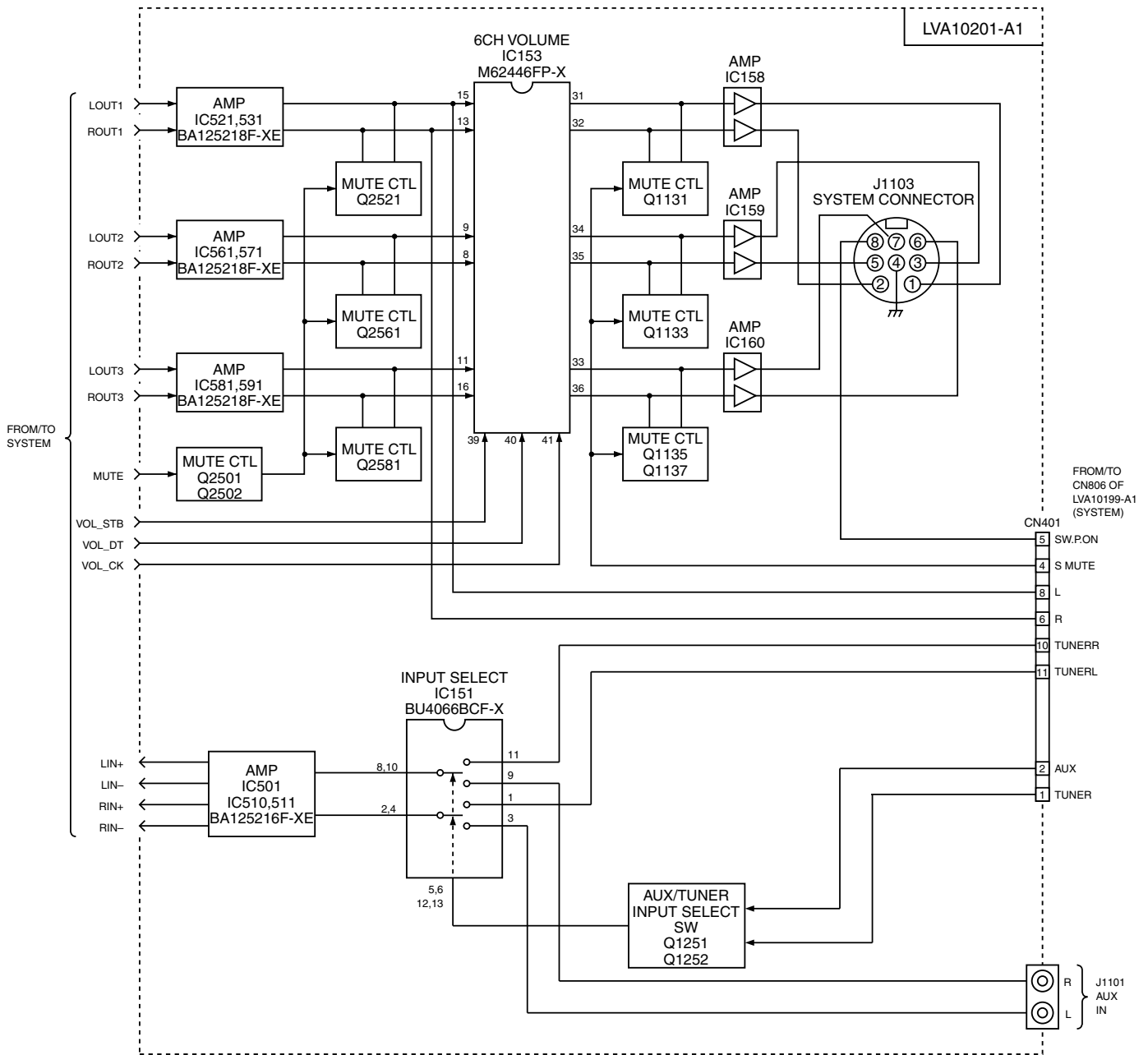

■ Block diagram (DSP section)

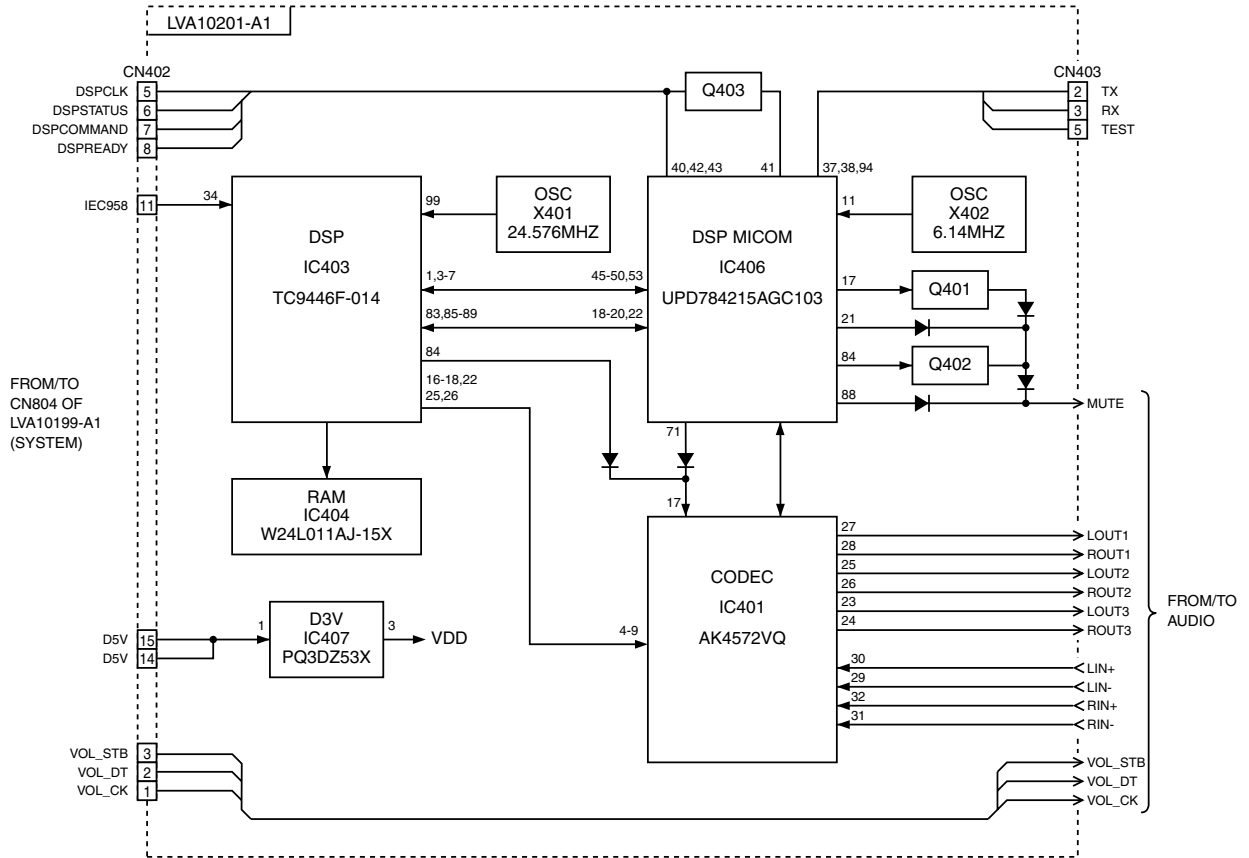

■ Block diagram (video input/output section)

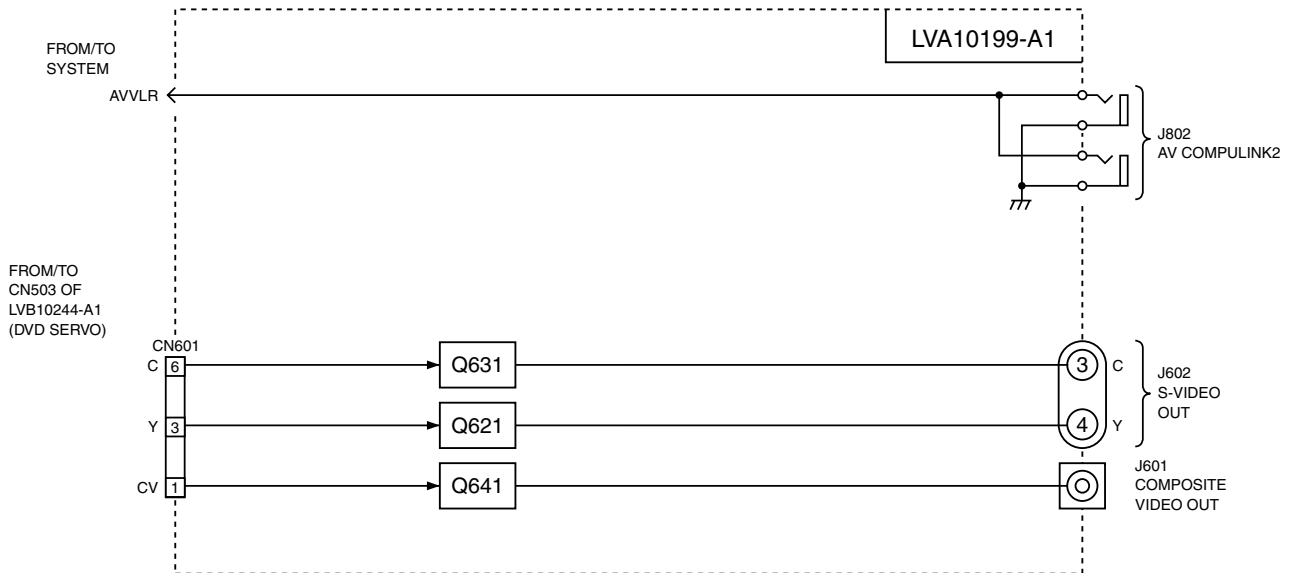

■ Block diagram (system control section)

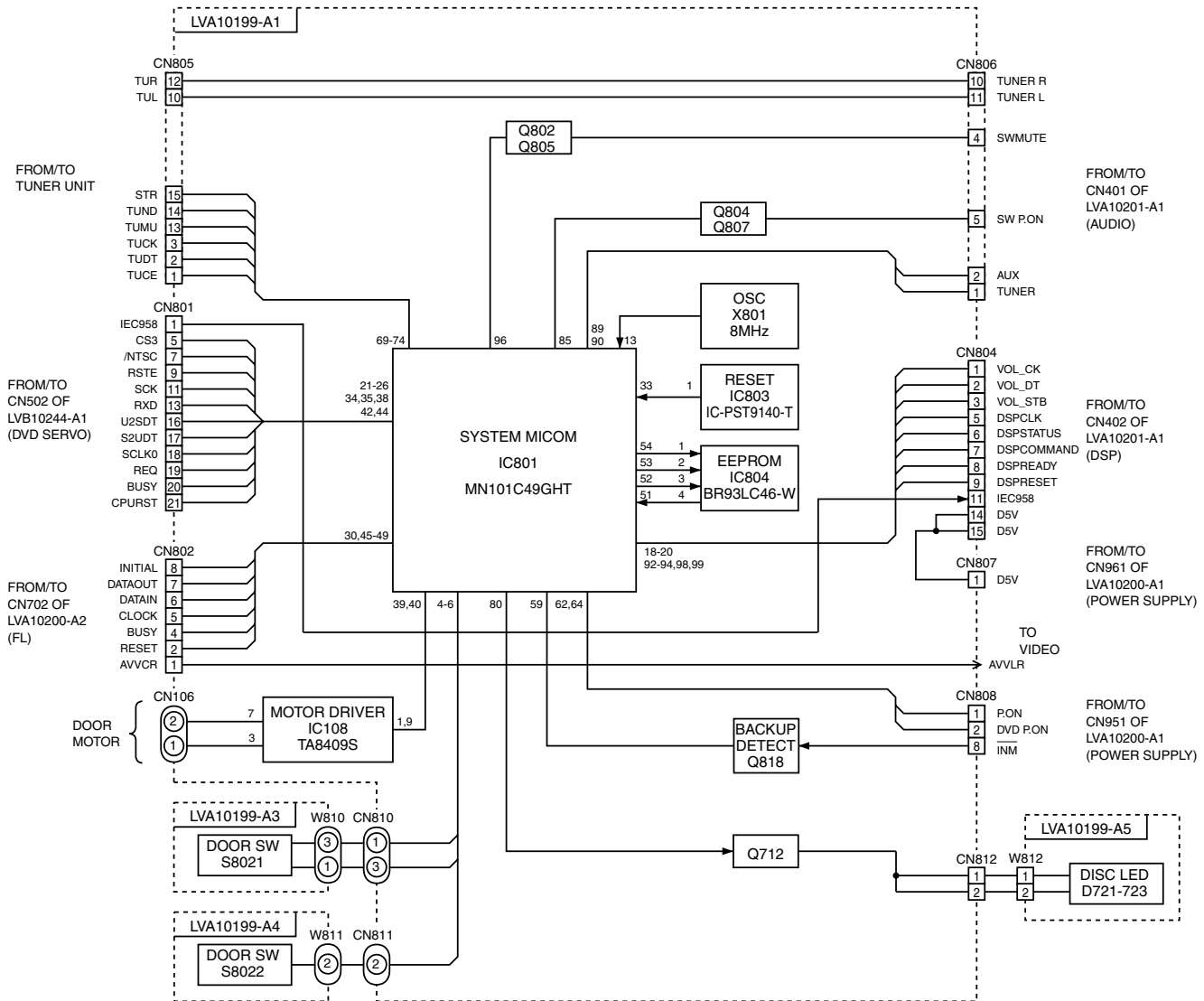

■ Block diagram (FL section)

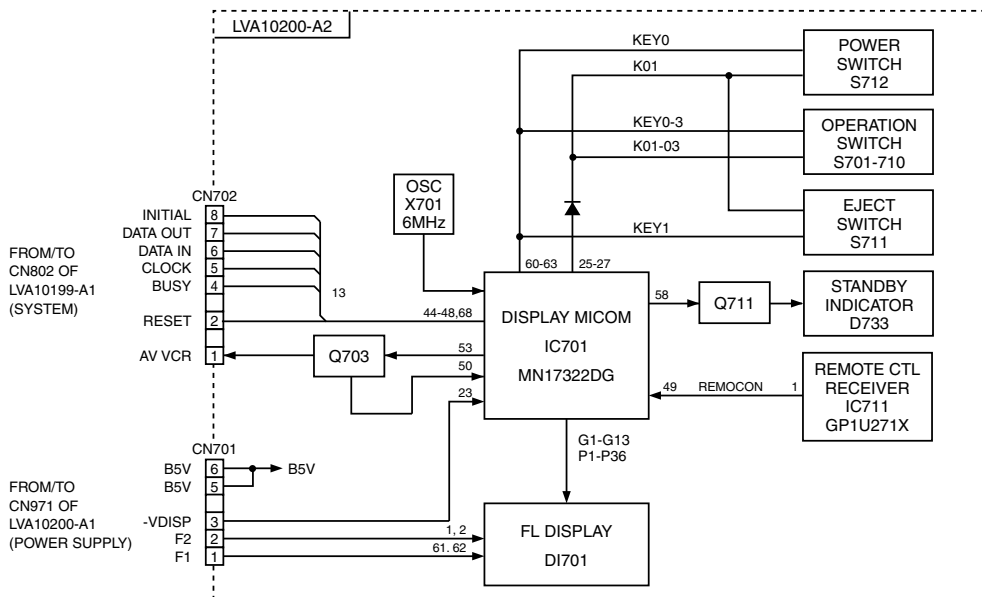

Standard schematic diagrams

System control circuit

7
6
5
4
3
2
1

TO DVD (INTERFACE)
TO CN502 OF LVA10244-A1 (SHEET 8/9)
TO DVD (POWER)
TO CN501 OF LVA10244-A1 (SHEET 7/9)
TO POWER
TO CN961 OF LVA10200-A1 (SHEET 1/9)
TO POWER
TO CN951 OF LVA10200-A1 (SHEET 1/9)
TO FRONT
TO CN702 OF LVA10200-A2 (SHEET 4/9)

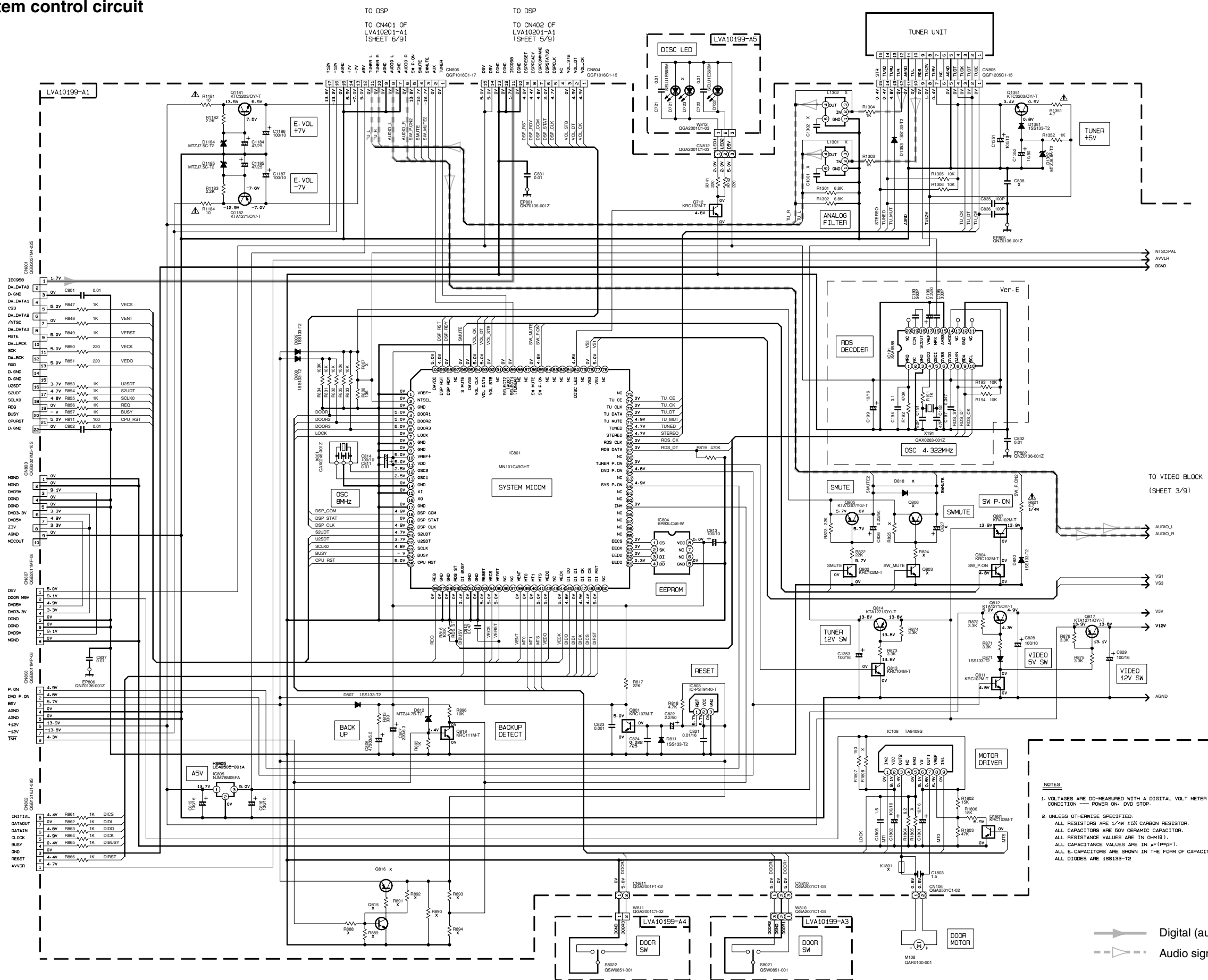

- NOTES**
1. VOLTAGES ARE DC-MEASURED WITH A DIGITAL VOLT METER WITHOUT INPUT SIGNAL. CONDITION --- POWER ON, DVD STOP.
 2. UNLESS OTHERWISE SPECIFIED:
ALL RESISTORS ARE 1/4W ±5% CARBON RESISTOR.
ALL CAPACITORS ARE 50V CERAMIC CAPACITOR.
ALL RESISTANCE VALUES ARE IN OHM(Ω).
ALL CAPACITANCE VALUES ARE IN μF(μF).
ALL E-CAPACITORS ARE SHOWN IN THE FORM OF CAPACITANCE(μF)/RATED VOLTAGE (V).
ALL DIODES ARE 1SS133-T2

— Digital (audio) signal
- - - Audio signal

Video input/output circuit

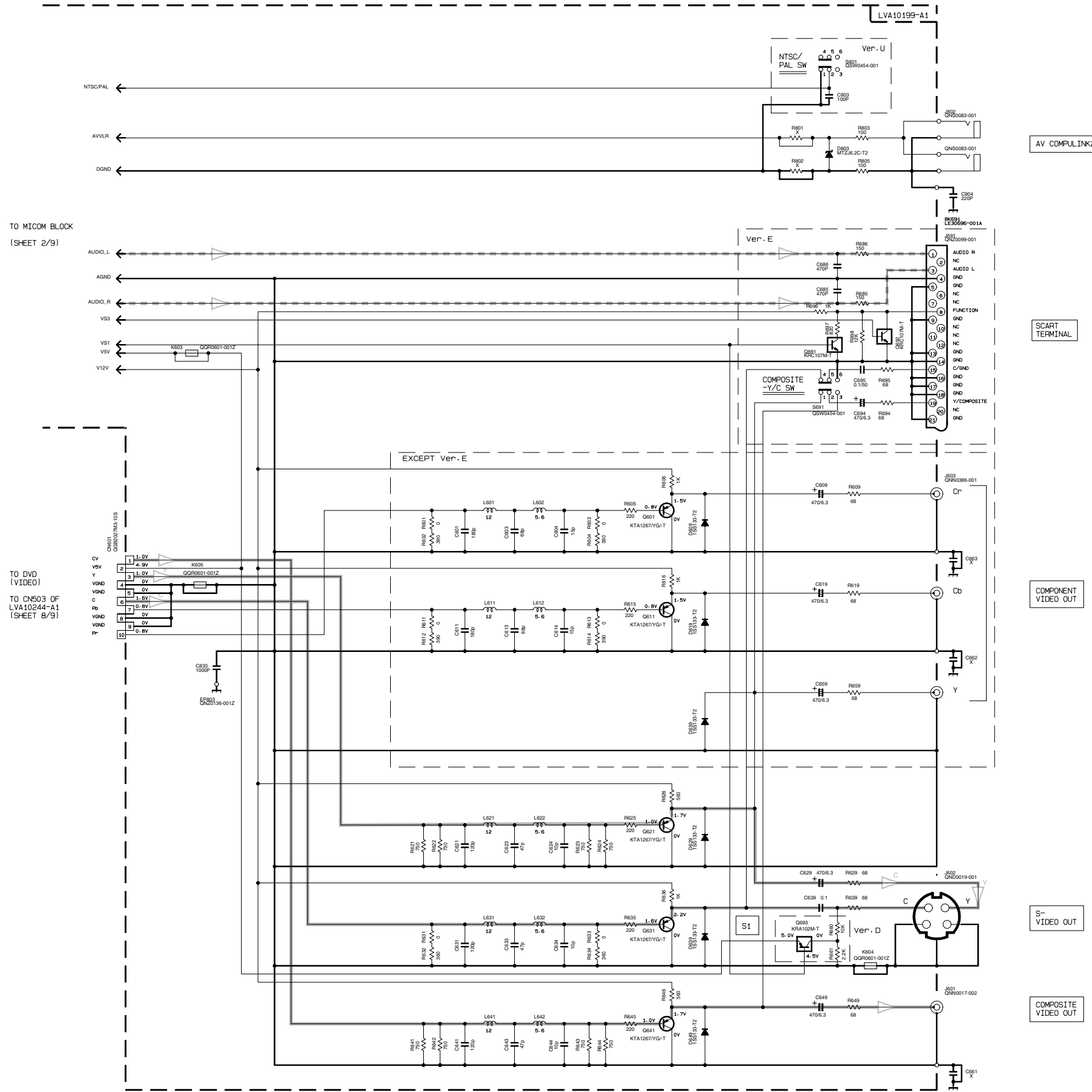





AV COMPLINK2

SCART TERMINAL

COMPONENT VIDEO OUT

S-VIDEO OUT

COMPOSITE VIDEO OUT

-  Video (composite) signal
-  Video (Y) signal
-  Video (C) signal
-  Audio signal

NOTES
 1. VOLTAGES ARE DC-MEASURED WITH A DIGITAL VOLT METER WITHOUT INPUT SIGNAL.
 CONDITION — POWER ON DVD STOP
 2. UNLESS OTHERWISE SPECIFIED:
 ALL RESISTORS ARE 1/4W 5% CARBON RESISTOR.
 ALL CAPACITORS ARE 50V CERAMIC CAPACITOR.
 ALL RESISTANCE VALUES ARE IN OHM(S).
 ALL CAPACITANCE VALUES ARE IN UF(PMF1).
 ALL E-CAPACITORS ARE SHOWN IN THE FORM OF CAPACITANCE(UF)/RATED VOLTAGE (V).
 ALL DIODES ARE 1SS133-12.

7
6
5
4
3
2
1

A B C D E F G H I J

Audio input/output circuit

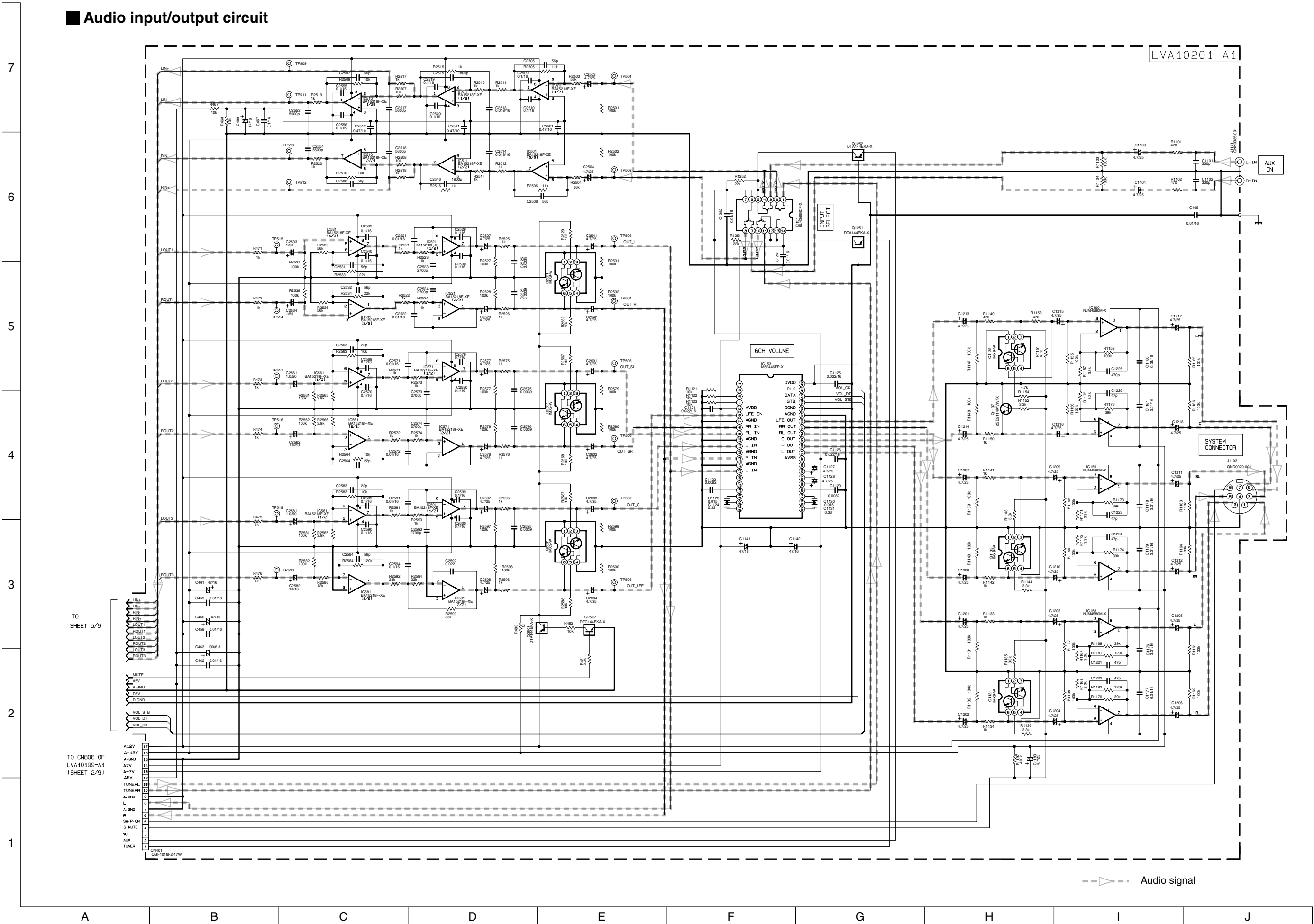

--- Audio signal

DVD servo circuit 1/2

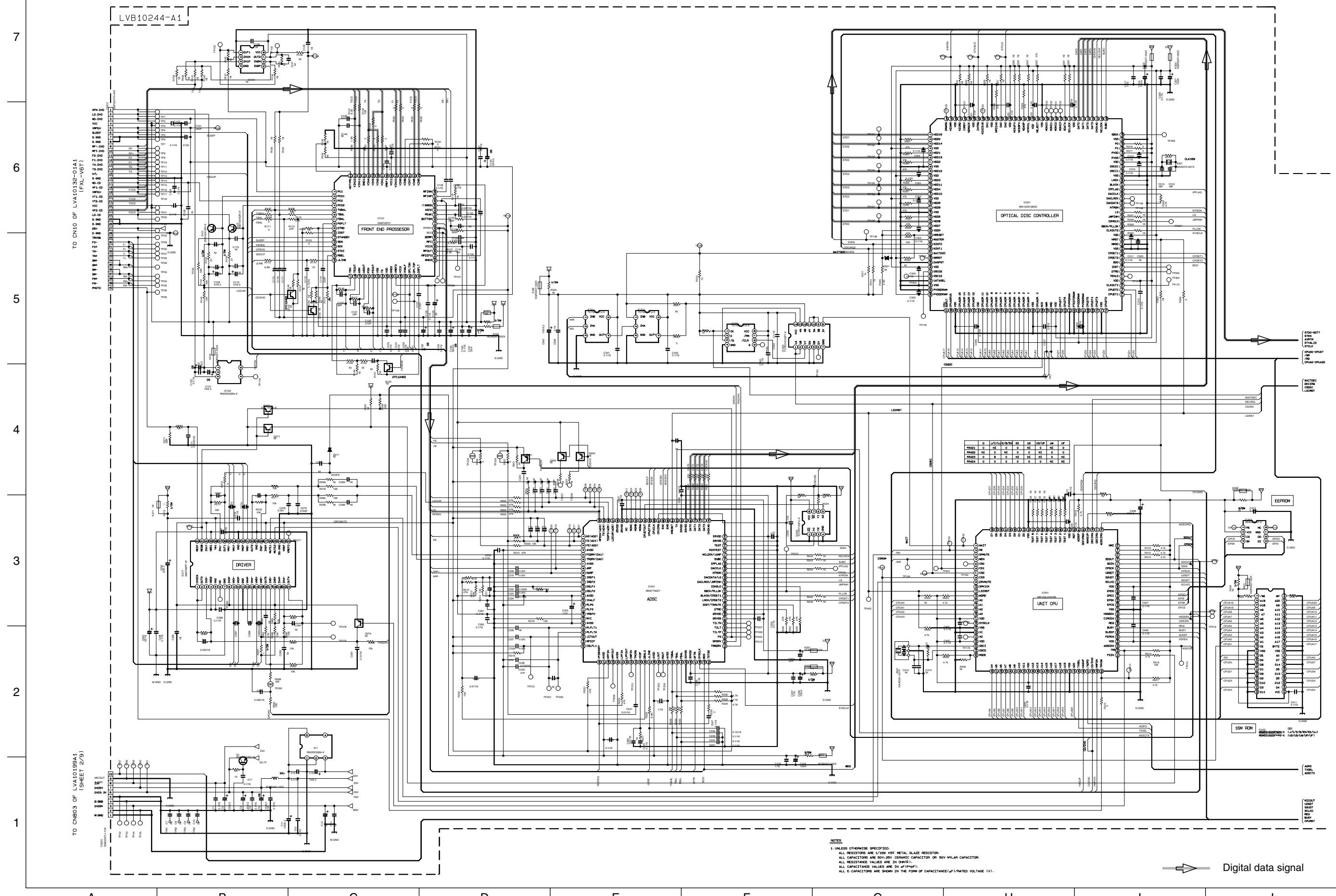

NOTES:
 1. UNLESS OTHERWISE SPECIFIED:
 ALL RESISTORS ARE 1/16W 45K METAL GLAZE RESISTOR.
 ALL CAPACITORS ARE 50V 20% CERAMIC CAPACITOR OR 50V MICLAR CAPACITOR.
 ALL RESISTANCE VALUES ARE IN OHMS (Ω).
 ALL CAPACITANCE VALUES ARE IN μF (μF).
 ALL CAPACITORS ARE SHOWN IN THE FORM OF CAPACITANCE (μF)/RATED VOLTAGE (V).

DVD servo circuit 2/2

7
6
5
4
3
2
1

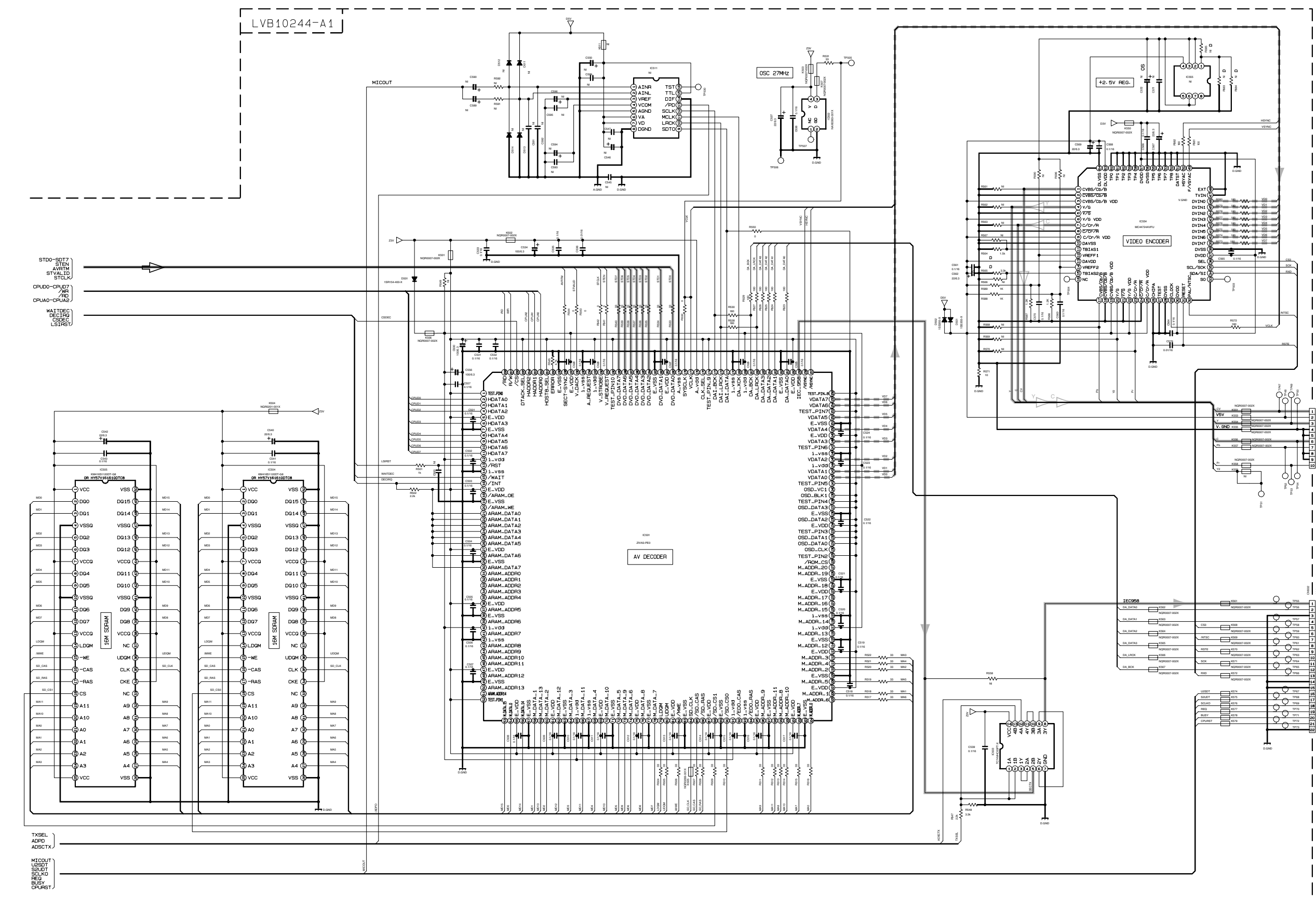

STD0-SDT7
AVTDM
STVAL1D
STCLK
CPU00-CPU07
M00-F00
CPUA0-CPUA2
WAITDEC
DECIRQ
OSCC
LSIRST

TXSEL
ADPO
ADSCXTX
MICOUT
LSPDT
SCLK
SCLKO
REQ
BUSY
CPUSET

LVB10244-A1

AV DECODER

VIDEO ENCODER

NOTES
1- UNLESS OTHERWISE SPECIFIED:
ALL RESISTORS ARE 1/8W ±5% METAL GLAZE RESISTOR.
ALL CAPACITORS ARE 50V, 25V CERAMIC CAPACITOR OR 50V MYLAR CAPACITOR.
ALL RESISTANCE VALUES ARE IN OHMS (Ω).
ALL CAPACITANCE VALUES ARE IN PICOFARAD (PF).
ALL E. CAPACITORS ARE SHOWN IN THE FORM OF CAPACITANCE (μF)/RATED VOLTAGE (V).

TO CN601 OF
LVA10199A1
(SHEET 3/9)

TO CN601 OF
LVA10199A1
(SHEET 2/9)

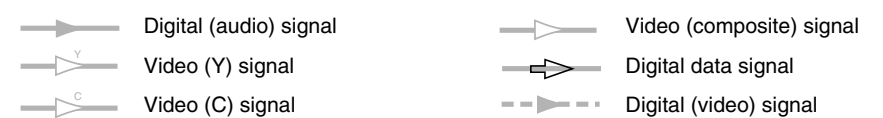

A B C D E F G H I J

FL circuit

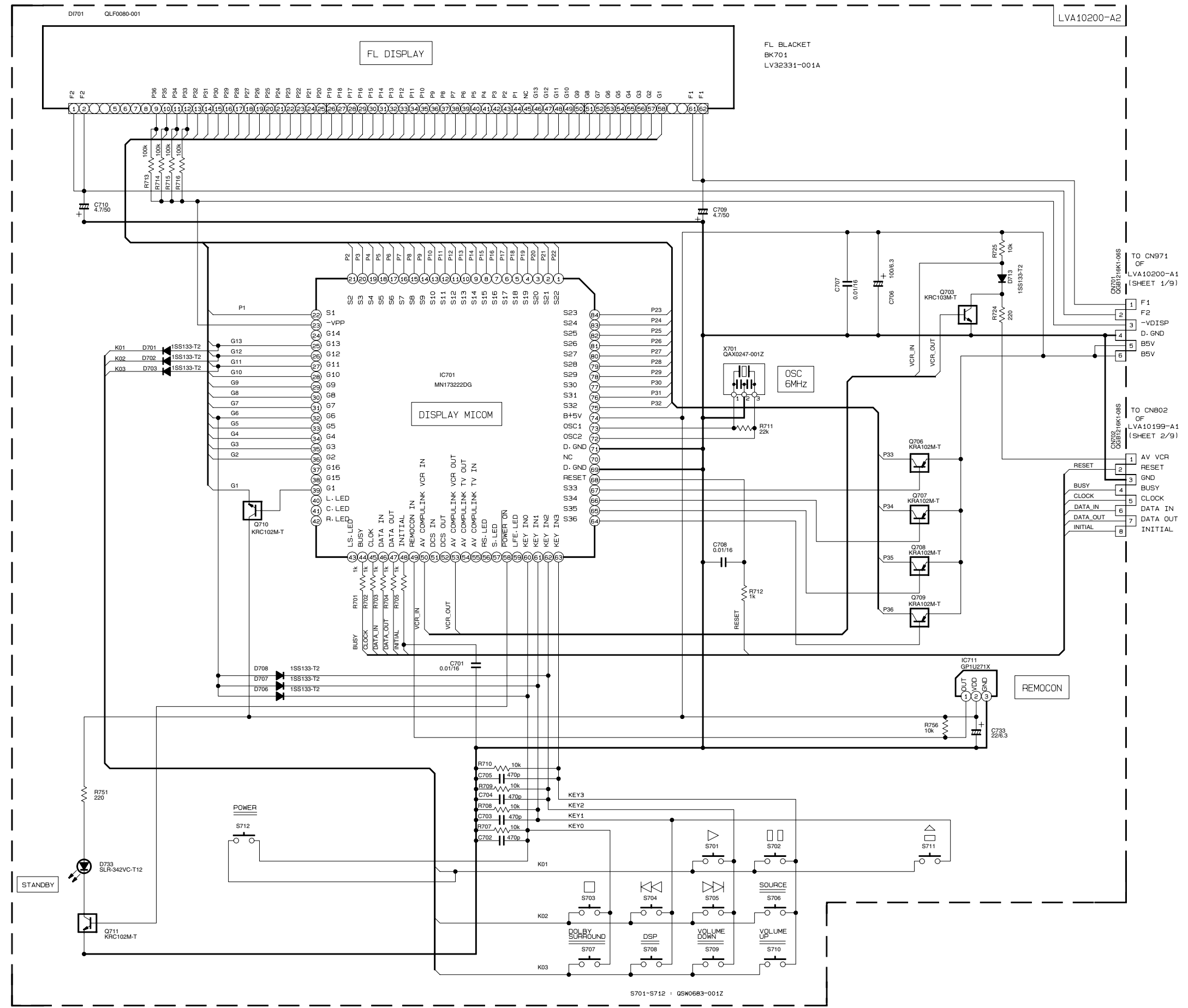

Version	D706	D707	D708
D	NONE	USE	NONE
C/J	NONE	NONE	NONE
B/E/EN/EE	USE	NONE	NONE
UG/UJ/UP/US	NONE	NONE	USE
UM	NONE	USE	USE

DSP circuit

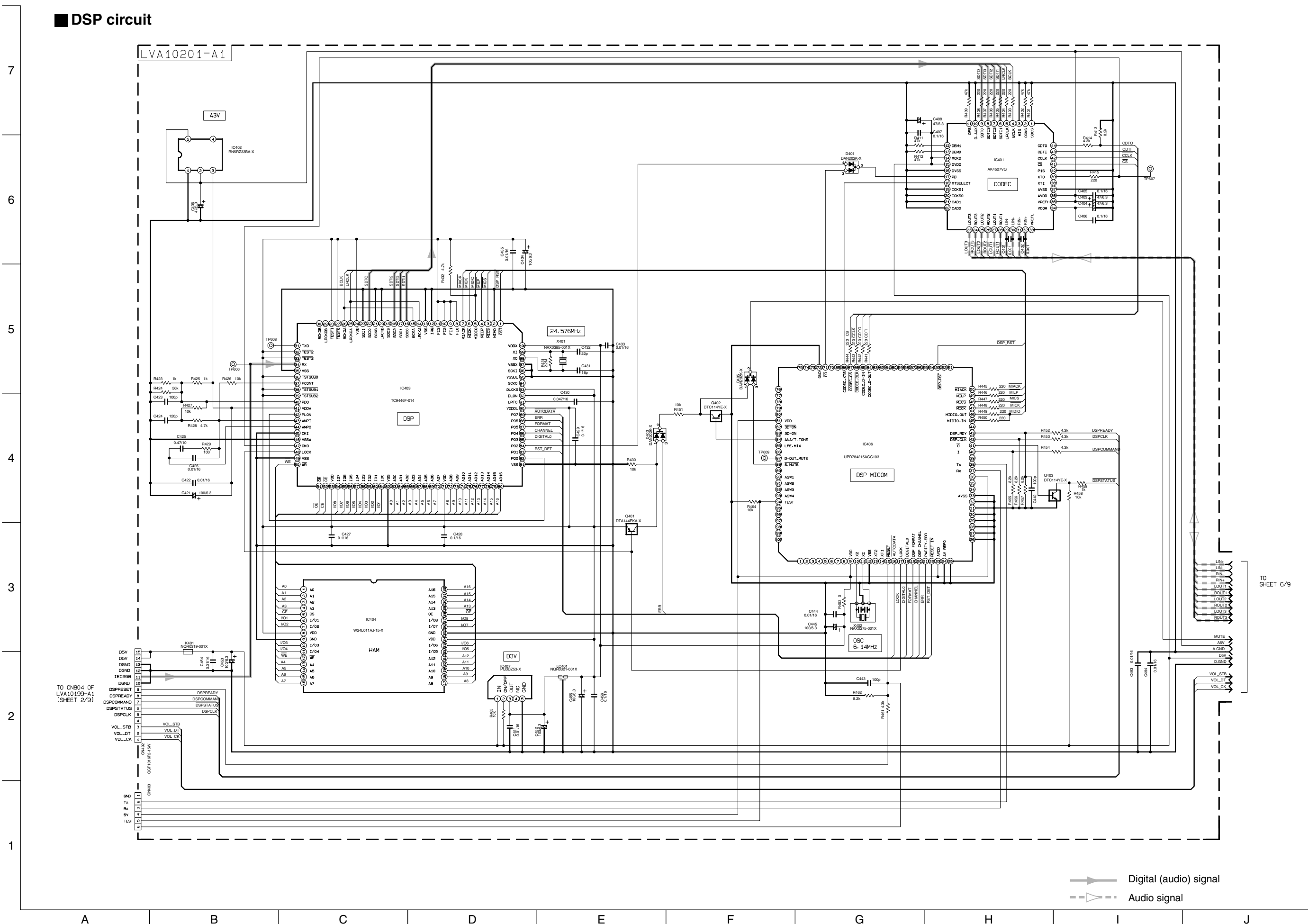

Digital (audio) signal
 Audio signal

TO SHEET 6/9

Power supply circuit

- Ver. J/C
120V 60Hz
- Ver. D
100V 50/60Hz
- Ver. B/E/EN/EE
230V 50Hz
- Ver. UG/US/UW/UJ
110~240V 50/60Hz
- Ver. UP
220V 60Hz
- Ver. UF
220V 50Hz

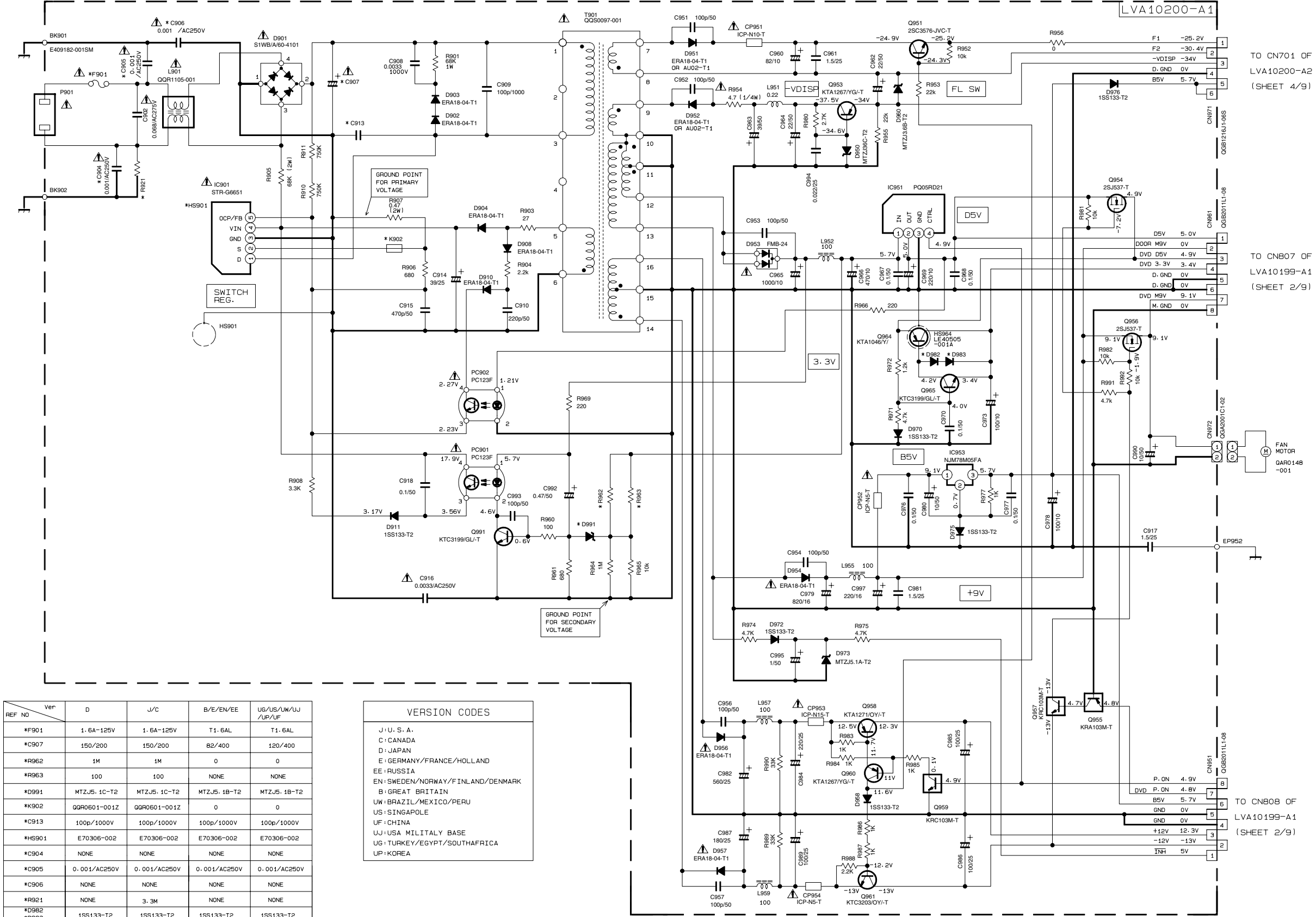

REF NO	Ver	D	J/C	B/E/EN/EE	UG/US/UW/UJ /UP/UF
*F901		1.6A-125V	1.6A-125V	T1.6AL	T1.6AL
*C907		150/200	150/200	B2/400	120/400
*R962		1M	1M	0	0
*R963		100	100	NONE	NONE
*D991		MTZJ5.1C-T2	MTZJ5.1C-T2	MTZJ5.1B-T2	MTZJ5.1B-T2
*K902		QDR0501-001Z	QDR0501-001Z	0	0
*C913		100p/1000V	100p/1000V	100p/1000V	100p/1000V
*HS901		E70306-002	E70306-002	E70306-002	E70306-002
*C904		NONE	NONE	NONE	NONE
*C905		0.001/AC250V	0.001/AC250V	0.001/AC250V	0.001/AC250V
*C906		NONE	NONE	NONE	NONE
*R921		NONE	3.3M	NONE	NONE
*D982		1SS133-T2	1SS133-T2	1SS133-T2	1SS133-T2
*D983		1SS133-T2	1SS133-T2	1SS133-T2	1SS133-T2
P901		QNC0006-001	QNC0046-001	QNC0006-001	QNC0006-001

VERSION CODES

- J : U. S. A.
- C : CANADA
- D : JAPAN
- E : GERMANY/FRANCE/HOLLAND
- EE : RUSSIA
- EN : SWEDEN/NORWAY/FINLAND/DENMARK
- B : GREAT BRITAIN
- UW : BRAZIL/MEXICO/PERU
- US : SINGAPOLE
- UF : CHINA
- UJ : USA MILITARY BASE
- UG : TURKEY/EGYPT/SOUTHAFRICA
- UP : KOREA

TO CN701 OF
LVA10200-A2
(SHEET 4/9)

TO CN807 OF
LVA10199-A1
(SHEET 2/9)

TO CN808 OF
LVA10199-A1
(SHEET 2/9)

Voltage value table

IC102

NO	DC(V)
1	0V
2	5.0V
3	0V
4	4.3V
5	0V

IC101

NO	DC(V)	NO	DC(V)	NO	DC(V)	NO	DC(V)
1	0V	17	1.7V	33	0V	49	2.2V
2	4.2V	18	1.7V	34	1.3V	50	2.2V
3	0V	19	1.7V	35	2.4V	51	2.2V
4	4.3V	20	1.7V	36	3.3V	52	2.2V
5	1.7V	21	1.7V	37	1.9V	53	2.2V
6	1.7V	22	1.7V	38	2.4V	54	2.2V
7	1.7V	23	0V	39	0V	55	4.8V
8	4.1V	24	1.7V	40	0V	56	2.2V
9	3.3V	25	3.3V	41	1.7V	57	2.2V
10	0V	26	0V	42	1.5V	58	2.2V
11	4.9V	27	2.1V	43	1.6V	59	2.2V
12	4.9V	28	4.8V	44	1.1V	60	2.2V
13	4.9V	29	4.8V	45	2.5V	61	0V
14	4.9V	30	2.1V	46	2.1V	62	2.2V
15	1.2V	31	2.1V	47	2.1V	63	2.2V
16	1.7V	32	2.0V	48	2.1V	64	1.6V

IC311

NO	DC(V)
1	5.0V
2	4.6V
3	0V
4	4.7V
5	5.0V

IC312

NO	DC(V)
1	5.0V
2	4.7V
3	0V
4	5.0V
5	5.0V

IC321

NO	DC(V)
1	5.0V
2	5.0V
3	5.0V
4	0V
5	0V
6	0V
7	5.0V
8	5.0V

IC322

NO	DC(V)
1	5.0V
2	5.0V
3	0V
4	0V
5	0V
6	5.0V
7	0V
8	5.0V
9	0V
10	0V
11	0V
12	5.0V
13	5.0V
14	5.0V

IC201

NO	DC(V)	NO	DC(V)	NO	DC(V)	NO	DC(V)
1	1.7V	26	2.1V	76	1.7V	51	1.7V
2	1.7V	27	3.2V	77	1.1V	52	1.7V
3	1.7V	28	1.7V	78	1.1V	53	3.2V
4	3.2V	29	0V	79	1.1V	54	0V
5	1.7V	30	0V	80	1.1V	55	0V
6	1.7V	31	1.7V	81	0V	56	0V
7	0V	32	0V	82	3.3V	57	0V
8	1.6V	33	1.7V	83	3.3V	58	2.6V
9	1.6V	34	1.7V	84	4.8V	59	0V
10	1.5V	35	0.1V	85	4.9V	60	0V
11	1.5V	36	1.6V	86	4.9V	61	0V
12	1.7V	37	1.7V	87	3.3V	62	0V
13	1.5V	38	3.2V	88	4.9V	63	0V
14	3.2V	39	1.6V	89	4.9V	64	0V
15	1.7V	40	1.6V	90	0.5V	65	0V
16	2.7V	41	0V	91	1.7V	66	0V
17	0.2V	42	1.7V	92	2.5V	67	3.3V
18	2.2V	43	1.7V	93	3.3V	68	1.7V
19	1.5V	44	1.7V	94	0.7V	69	3.3V
20	0V	45	0V	95	0V	70	2.5V
21	1.6V	46	3.3V	96	2.6V	71	0V
22	1.6V	47	0V	97	1.8V	72	0V
23	1.5V	48	1.7V	98	1.6V	73	0V
24	1.7V	49	0V	99	1.6V	74	0V
25	1.5V	50	0.3V	100	1.7V	75	3.3V

IC202

NO	DC(V)
1	0V
2	3.3V
3	4.9V
4	0V
5	0V
6	4.9V
7	0V
8	4.9V

IC301

NO	DC(V)	NO	DC(V)	NO	DC(V)	NO	DC(V)
1	3.3V	37	0V	73	0.8V	109	2.5V
2	3.3V	38	0.3V	74	0.8V	110	0V
3	3.3V	39	0V	75	1.7V	111	1.7V
4	3.3V	40	4.1V	76	3.3V	112	1.1V
5	0V	41	4.3V	77	0V	113	1.1V
6	3.3V	42	4.2V	78	3.3V	114	1.1V
7	3.3V	43	1.6V	79	0V	115	1.1V
8	0V	44	2.6V	80	3.3V	116	3.3V
9	3.3V	45	3.3V	81	0V	117	3.3V
10	3.6V	46	3.6V	82	0V	118	3.3V
11	3.3V	47	3.7V	83	0V	119	0V
12	3.3V	48	3.8V	84	0V	120	0V
13	3.3V	49	3.7V	85	4.8V	121	0V
14	3.3V	50	3.8V	86	2.6V	122	0V
15	3.3V	51	1.0V	87	1.7V	123	0V
16	3.3V	52	1.0V	88	0V	124	3.3V
17	3.3V	53	3.6V	89	0V	125	2.6V
18	0V	54	3.8V	90	0V	126	1.3V
19	0V	55	1.0V	91	0V	127	0V
20	3.3V	56	0V	92	3.3V	128	1.4V
21	3.3V	57	0.7V	93	0V	129	1.1V
22	4.5V	58	4.9V	94	3.3V	130	3.3V
23	4.5V	59	4.9V	95	0V	131	1.6V
24	0V	60	4.4V	96	3.3V	132	3.3V
25	0.1V	61	3.3V	97	0V	133	0V
26	4.9V	62	1.2V	98	0V	134	0V
27	4.9V	63	2.4V	99	0V	135	3.3V
28	1.4V	64	0V	100	1.6V	136	1.3V
29	0V	65	0V	101	1.6V	137	0V
30	3.3V	66	2.6V	102	3.3V	138	3.3V
31	0V	67	0V	103	0V	139	1.3V
32	3.3V	68	1.0V	104	3.3V	140	1.0V
33	0V	69	2.1V	105	3.3V	141	1.1V
34	0V	70	1.0V	106	3.3V	142	0V
35	0V	71	0V	107	0V	143	3.3V
36	2.6V	72	2.3V	108	0V	144	3.3V

IC401

NO	DC(V)	NO	DC(V)	NO	DC(V)	NO	DC(V)
1	5.0V	26	2.7V	51	0.6V	76	5.0V
2	5.0V	27	1.8V	52	5.0V	77	5.0V
3	5.0V	28	2.1V	53	5.0V	78	3.1V
4	5.0V	29	1.7V	54	5.0V	79	0V
5	0V	30	3.5V	55	5.0V	80	5.0V
6	5.0V	31	3.5V	56	5.0V	81	5.0V
7	5.0V	32	2.1V	57	0V	82	4.9V
8	4.4V	33	2V	58	0V	83	5.0V
9	5.0V	34	5.0V	59	5.0V	84	5.0V
10	0V	35	2.6V	60	0V	85	0V
11	4.9V	36	4.3V	61	0V	86	0V
12	5.0V	37	4V	62	0V	87	0V
13	0V	38	0V	63	0V	88	5.0V
14	0V	39	5V	64	0V	89	5.0V
15	2.1V	40	0V	65	0V	90	5.0V
16	1.9V	41	0V	66	5.0V	91	5.0V
17	5.0V	42	0V	67	4.8V	92	0V
18	2.3V	43	0V	68	3.8V	93	1.1V
19	0V	44	0V	69	4.8V	94	1.5V
20	0V	45	0V	70	5.0V	95	0V
21	5.0V	46	0V	71	0V	96	0V
22	5.0V	47	0V	72	5.0V	97	2.3V
23	2.4V	48	5V	73	5.0V	98	2.3V
24	2.4V	49	0V	74	5.0V	99	2.3V
25	5.0V	50	5.0V	75	5.0V	100	2.4V

IC403

NO	DC(V)
1	4.9V
2	5.0V
3	0V
4	0V
5	0V
6	1.0V
7	0V
8	0V

IC402

NO	DC(V)	NO	DC(V)
1	4.9V	23	5V
2	0V	24	2.3V
3	0V	25	0V
4	3.5V	26	2.3V
5	1.7V	27	0V
6	2.1V	28	2.3V
7	1.8V	29	0V
8	2.7V	30	2.4V
9	1.9V	31	0V
10	2.1V	32	0V
11	0V	33	0V
12	4.6V	34	0V
13	0V	35	5V
14	4.2V	36	0V
15	1.1V	37	4V
16	0V	38	4.3V
17	1.5V	39	2.6V
18	0V	40	2V
19	0V	41	2.1V
20	0V	42	3.5V
21	0V	43	0V
22	0V	44	0V

VOLTAGES ON SHEET 7/9

IC502

NO	DC(V)
1	3.1V
2	0V
3	1.6V
4	3.2V

IC501

NO	DC(V)	NO	DC(V)	NO	DC(V)	NO	DC(V)
1	3.1V	53	0.7V	105	0V	157	0.9V
2	1.7V	54	0.7V	106	0V	158	0.9V
3	0.7V	55	3.1V	107	3.1V	159	0V
4	2.0V	56	0.6V	108	0V	160	3.1V
5	3.1V	57	0V	109	0V	161	0V
6	1.6V	58	0.6V	110	0V	162	0V
7	0V	59	0.5V	111	0V	163	0V
8	0V	60	0.5V	112	0V	164	0V
9	2.4V	61	3.1V	113	3.1V	165	0V
10	2.9V	62	0.6V	114	0V	166	0V
11	2.6V	63	0V	115	0V	167	0V
12	2.5V	64	0.6V	116	0V	168	2.5V
13	5.0V	65	2.5V	117	2.5V	169	0.9V
14	0V	66	0.7V	118	0V	170	0V
15	5.0V	67	0V	119	0V	171	0V
16	3.1V	68	0.7V	120	0V	172	1.6V
17	3.1V	69	3.1V	121	0V	173	1.6V
18	3.1V	70	0.6V	122	0V	174	3.1V
19	0V	71	0V	123	3.1V	175	3.1V
20	3.1V	72	0.7V	124	0V	176	3.1V
21	3.1V	73	0.7V	125	0V	177	1.6V
22	3.1V	74	0.6V	126	0V	178	3.1V
23	3.1V	75	3.1V	127	0V	179	0V
24	3.1V	76	0.7V	128	0.8V	180	5.0V
25	3.1V	77	0V	129	3.1V	181	3.1V
26	3.1V	78	0.8V	130	3.1V	182	5.0V
27	3.1V	79	3.2V	131	3.1V	183	0V
28	3.1V	8					

Powered subwoofer circuit (SP-PWA9)

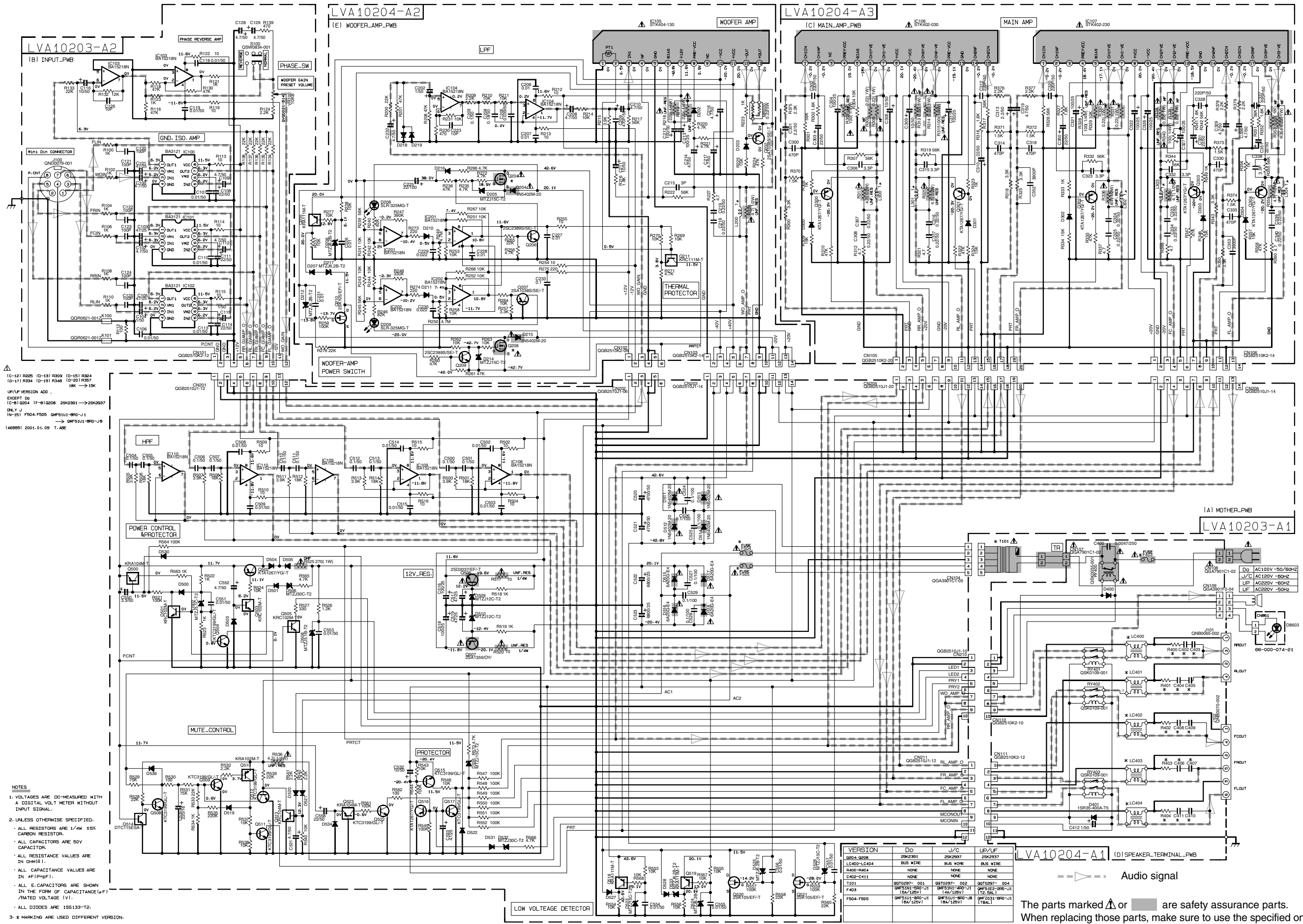

(C-12) R205 (D-13) R309 (D-15) R304
 (D-17) R334 (D-19) R348 (D-20) R357
 10K → 10K
 U/F VERSION ADD .
 EXCEPT DO (C-8) Q208 29K291 → 29K337
 DLY J (N-15) F504-F505 981511-000-11
 → 981511-000-11
 (A6885) 2001-01-09 T.ABC

NOTES
 1. VOLTAGES ARE DC-MEASURED WITH A DIGITAL VOLT METER WITHOUT INPUT SIGNAL.
 2. UNLESS OTHERWISE SPECIFIED, ALL RESISTORS ARE 1/4W 5% CARBON RESISTOR.
 3. ALL CAPACITORS ARE 50V CAPACITOR.
 4. ALL RESISTANCE VALUES ARE IN OHM(Ω).
 5. ALL CAPACITANCE VALUES ARE IN #F(P=PF).
 6. ALL E-CAPACITORS ARE SHOWN IN THE FORM OF CAPACITANCE(LF) / RATED VOLTAGE (V).
 7. ALL DIODES ARE 1SS133-T2.
 8. * MARKING ARE USED DIFFERENT VERSION.

---▶--- Audio signal
 The parts marked or are safety assurance parts. When replacing those parts, make sure to use the specified one.

PARTS LIST

[TH-A9]

* All printed circuit boards and its assemblies are not available as service parts.

Area suffix	
J	U.S.A.
C	Canada

- Contents -

Exploded view of general assembly and parts list	3- 3
DVD mechanism assembly and parts list	3- 5
Exploded view of general assembly and parts list (SP-THA9)	3- 7
Electrical parts list	3- 9
Packing materials and accessories parts list	3-28

< MEMO >

Exploded view of general assembly and parts list

Block No. M 1 M M

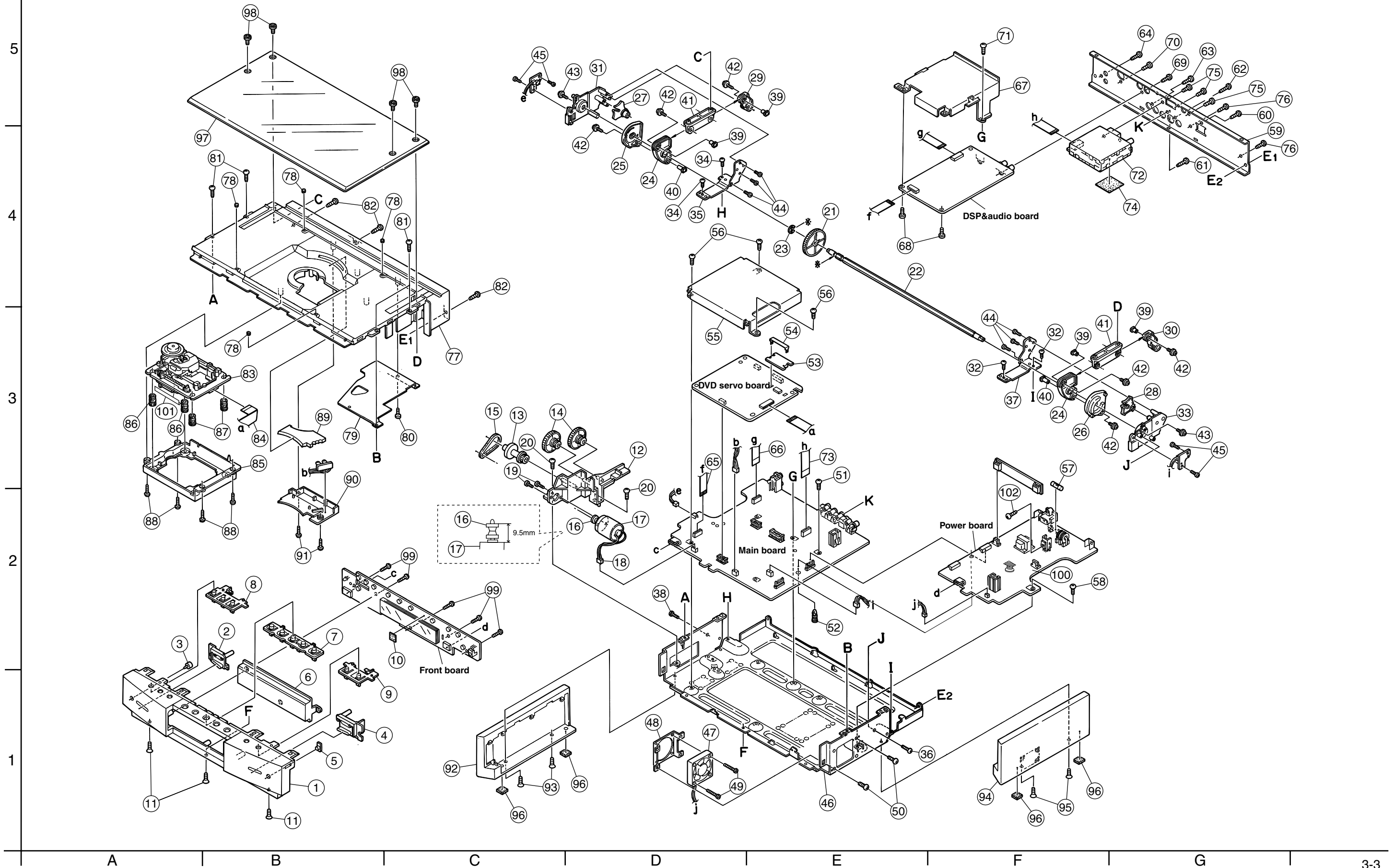

■ Parts list (General assembly)

Block No. M1MM

△	Item	Parts number	Parts name	Q'ty	Description	Area
	1	LV10441-002A	FRONT PANEL	1		
	2	LV32329-001A	PUSH BUTTON	1	POWER	
	3	VJK4493-001SC	LENS(STANDBY)	1	STANDBY LED	
	4	LV32330-001A	PUSH BUTTON	1	OPEN	
	5	E408131-001	REMOTE LENS	1	REMOTE	
	6	LV20891-001A	LENS	1	AS	
	7	LV20890-001A	PUSH BUTTON	1	PS/PLAY	
	8	LV32332-001A	PUSH BUTTON	1	PS/LEFT	
	9	LV32333-001A	PUSH BUTTON	1	PS/RIGHT	
	10	LE30001-011A	SPACER	1		
	11	QYSSST3006Z	SCREW	3	F.P+B.CHASSIS	
	12	LV20892-001A	MOTOR BASE	1	ABS	
	13	LV42027-001A	GEAR 1	1		
	14	LV42028-001A	GEAR 2	2		
	15	LV41598-001A	BELT	1		
	16	LV41536-001A	PULLEY	1		
	17	QAR0100-001	DC MOTOR	1		
	18	WJM0133-002A	E-SI C WIRE	1		
	19	QYSPSP3004Z	SCREW	2	DC MOTOR+M.BASE	
	20	QYSBST3008Z	T.SCREW	2	MOTER.B+BOTTOM.	
	21	LV42029-001A	MAIN GEAR	1		
	22	LV32341-001A	SHAFT 1	1		
	23	QYREE6000X	E RING	1	MAIN GEAR	
	24	LV31690-001A	ARM	2	ABS	
	25	LV31691-001A	G.WHEEL(L)	1		
	26	LV31692-001A	G.WHEEL(R)	1		
	27	LV31693-001A	G.GEAR(L)	1	PBT	
	28	LV31694-001A	G.GEAR(R)	1	PBT	
	29	LV31695-001A	ARM GEAR(L)	1	PBT	
	30	LV31696-001A	ARM GEAR(R)	1	PBT	
	31	LV31697-002A	GEAR BASE(L)	1	PBT	
	32	QYSBST3006Z	T.SCREW	2	GEAR.B+BOTTOM	
	33	LV31698-002A	GEAR BASE(R)	1	PBT	
	34	QYSBST3006Z	T.SCREW	2	GEAR.B+BOTTOM	
	35	LV32127-001A	GEAR BKT(L)	1	EGC T1	
	36	QYSBSF2606Z	SCREW	1		
	37	LV32128-001A	GEAR BKT(R)	1	EGC T1	
	38	QYSBSF2606Z	SCREW	1		
	39	LV41929-001A	SHAFT 4	4	PBT	
	40	LV41930-001A	SHAFT 5	2	PBT	
	41	LV32334-001A	DOOR BASE	2		
	42	QYSPSFG2605N	SCREW	6	DOOR BASE+ARM	
	43	QYSPSPG3006Z	SCREW	2	SAFT 1+G.BASE	
	44	QYSDSF2606Z	SCREW	6	G.BKT+G.BASE	
	45	QYSDSF2606Z	SCREW	4	SW.PWB+G.BASE	
	46	LV10443-001A	BOTTOM CHASSIS	1	EGC T1.0	
	47	QAR0148-001	FAN MOTOR	1		
	48	LV41799-001A	FAN BRACKET	1		
	49	QYSPST3012Z	T.SCREW	2	FAN + FAN BKT	
	50	QYSBST3006Z	T.SCREW	2	FAN BKT + B CHA	
	51	QYSBST3006Z	T.SCREW	1	BOTTOM+MAIN PWB	

■ Parts list (General assembly)

Block No. M1MM

△	Item	Parts number	Parts name	Q'ty	Description	Area
	52	LV42282-001A	FASTENER	1	MAIN + POWER	
	53	LV41362-201A	HEAT SINK	1	FOR DVD DRIVER	
	54	LV41363-202A	HOLDER	1	FOR HEAT SINK	
	55	LV32335-001A	SHIELD CASE	1	DVD PWB	
	56	QYSBST3006Z	T.SCREW	3	DVD SHIELD	
△	57	QMF51U1-1R6-J8	FUSE	1		
	58	QYSBST3006Z	T.SCREW	1	SUPPLY PWB	
	59	LV20928-002A	REAR PANEL	1	SECC T0.8	
	60	QYSBSGY3008M	SPECIAL SCREW	1	AC IN	
	61	QYSBSGY3008M	SPECIAL SCREW	1	COMPOSITE	
	62	QYSBSGY3008M	SPECIAL SCREW	1	S VIDEO	
	63	QYSBSGY3008M	SPECIAL SCREW	1	COMPONENT	
	64	QYSBSGY3008M	SPECIAL SCREW	1	AV COMPULINK	
	65	QUQ810-1509AJ	FFC WIRE	1	FROM CN402 TO C	
	66	QUQ810-1710AJ	FFC WIRE	1	FROM CN401 TO C	
	67	LV32336-001A	SHIELD CASE	1	EGC T0.8 DTS	
	68	QYSDSG3006N	T.SCREW	2	DTS+SHIELD	
	69	QYSBSGY3008M	SPECIAL SCREW	1	AUX IN	
	70	QYSDST3006M	SCREW	1	SYSTEM	
	71	QYSBST3006Z	T.SCREW	1	DTS+CHASSIS	
	72	QAU0233-001	TUNER	1	FM/AM TUNER PAC	
	73	QUQB12-1510AJ	FFC WIRE	1	FROM TUNER TO C	
	74	LV30225-081A	SPACER	1		
	75	QYSDST3006M	SCREW	3	TUNER	
	76	QYSBSGY3008M	SPECIAL SCREW	2	EARTH PLATE	
	77	LV10442-004A	TOP PANEL	1	PS/PAINT	
	78	LV41821-001A	FELT	4	TOP(CD DOOR)	
	79	LV32538-001A	SHIELD CASE	1		
	80	QYSDSF2606Z	SCREW	1	TOP + SHIELD CA	
	81	QYSBST3006Z	T.SCREW	4	BOTTOM.C+TOP	
	82	QYSBSGY3008M	SPECIAL SCREW	3	TOP+REAR	
	83	-----	DVD TRAVERSE ME	1	CD MECHA	
	84	QUQ605-4020AJ	FFC WIRE	1	DVD MECHA TO DVD CB	
	85	LV20927-001A	MECHA HOLDER	1	PS	
	86	LV41120-003A	INSULATOR	2	HARD(T.TABLE)	
	87	LV41120-004A	INSULATOR	2	SOFT	
	88	QYSBSF2608Z	T.SCREW	4	M.HOLDER+TOP	
	89	LV32340-001A	INDICATOR	1	AS	
	90	LV32338-001A	LED COVER	1	AS	
	91	QYSBSF2608Z	T.SCREW	2	AS	
	92	LV10445-002A	SIDE PANEL(L)	1	PS/PAINT	
	93	QYSSST3006Z	SCREW	2	S.PANEL+BOTTOM	
	94	LV10446-002A	SIDE PANEL(R)	1	PS/PAINT	
	95	QYSSST3006Z	SCREW	2	S.PANEL+BOTTOM	
	96	E75896-002	FELT SPACER	4	FOOT	
	97	LV10444-001A	DOOR	1	PMMA	
	98	LV41587-001A	SPECIAL SCREW	4	DOOR+D.BASE	
	99	QYSDSF2608Z	SCREW	5	FRONT C.B	
	100	LV30225-0B3A	SPACER	1		
	101	VYSA1R4-050	SPACER	1	L952	
	102	QYSBSE3008Z	SCREW	1	FOR IC901+HS901	

DVD mechanism assembly and parts list

Block No. M 2 M M

FXL-V6T-2C

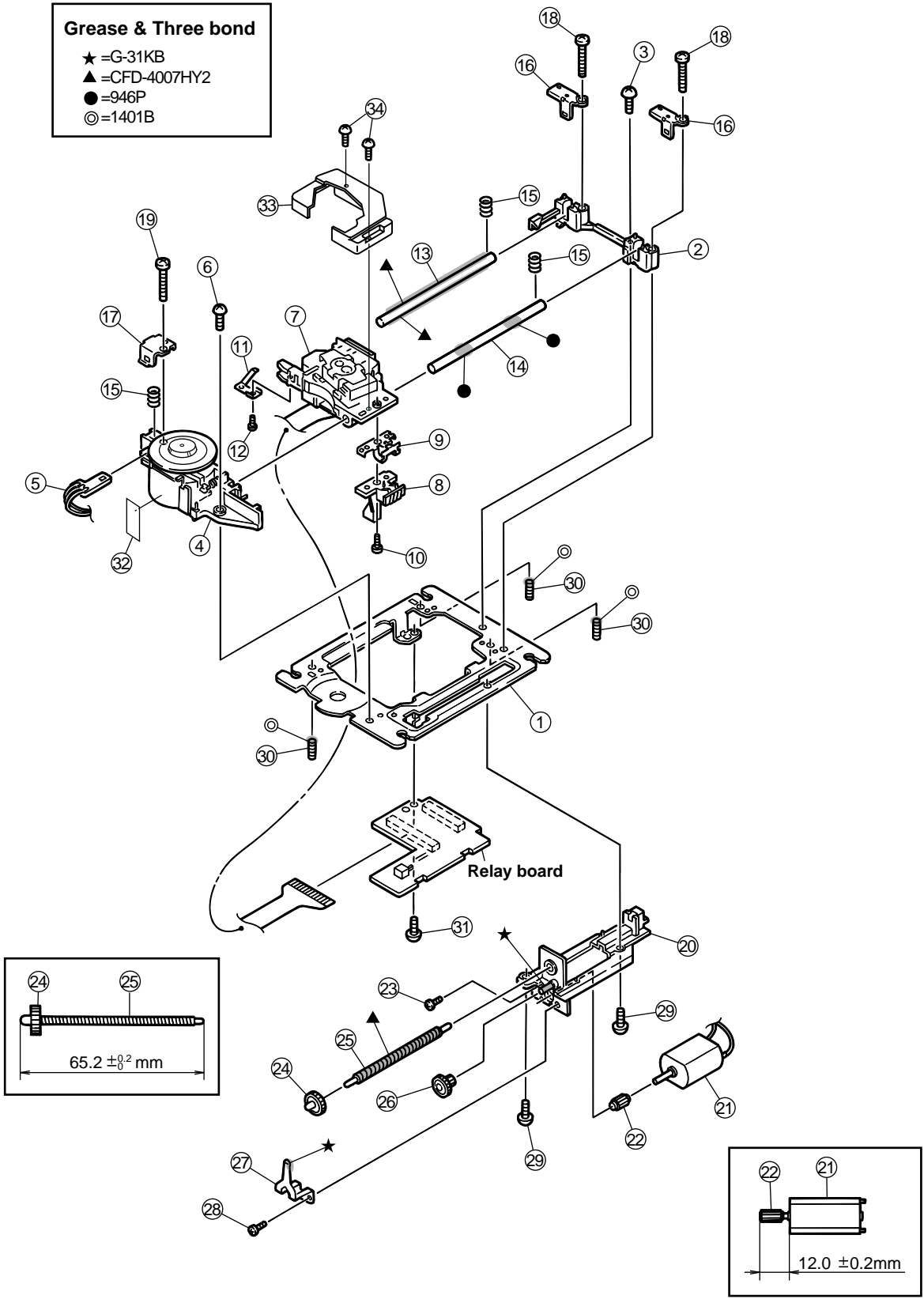

■ Parts list (DVD mechanism)

Block No. M2MM

△	Item	Parts number	Parts name	Q'ty	Description	Area
	1	LV20638-001A	MECHA BASE	1		
	2	LV20635-001A	SHAFT HOLDER	1		
	3	QYSBST2606M	T.SCREW	1		
	4	FXL-V6TSPSV-1C	SP.MOTOR ASSY	1		
	5	QUM193-08B2B2	PARA RIBON WIRE	1		
	6	QYSBST2606M	T.SCREW	1	FOR S.BASE&M.BASE	
	7	OPTIMA-2010A3	DVD PICK UP	1		
	8	LV31670-001A	SWITCH ACTUATOR	1		
	9	LV31666-002A	LEAD SPRING	1		
	10	QYSPSGT2040M	SCREW	1		
	11	LV31743-002A	P.U. SPRING	1		
	12	QYSPSGT1416M	MINI SCREW	1	FOR PU.SPRING	
	13	LV41121-002A	SHAFT	1	MAIN SHAFT	
	14	LV41121-002A	SHAFT	1	SUB SHAFT	
	15	LV41732-001A	SKEW SPRING	3		
	16	LV31669-001A	SHAFT STOPPER R	2		
	17	LV31668-001A	SHAFT STOPPER F	1		
	18	QYSPST2614M	SCREW	2	FOR SSTOPER R	
	19	QYSPST2614M	SCREW	1	FOR SSTOPER F	
	20	LV31746-003A	FEED HOLDER ASY	1		
	21	QAR0127-001	FEED MOTOR	1		
	22	LV41510-001A	FEED GEAR T	1		
	23	QYSPSPU2040M	SCREW	1		
	24	LV41512-001A	FEED GEAR E	1		
	25	LV41517-001A	LEAD SCREW	1		
	26	LV41511-002A	FEED GEAR M	1		
	27	LV31667-001A	THRUST SPRING	1		
	28	QYSPSPU2040M	SCREW	1		
	29	QYSBST2606M	T.SCREW	2	FOR F.HOLDER	
	30	QYYASPF2608N	HEX SCREW	3	FOR TILT ADJUST	
	31	QYSBST2606M	T.SCREW	1	FOR PW BOARD	
	32	LV30225-0A4A	SPACER	1		
	33	LV32320-003A	PICK COVER	1		
	34	QYSPSGT1740M	TAP SCREW	2	FOR P.U. COVER	

■ Parts list (SP-THA9 General assembly)

Block No. M3MM

△	Item	Parts number	Parts name	Q'ty	Description	Area
	1	LV10447-001A	MOLD BASE	1		
	2	LV31723-001A	TRANS BRACKET	1		
	3	QYSBSF4008Z	SCREW	6	FOR TRANS BKT	
△	4	QQT0297-002	P.TRANS	1		
	5	E406309-002	SPACER	4		
	6	QYSDSTL4010E	SPECIAL SCREW	4		
	7	LV30225-078A	SPACER	1		
△	8	QMF51N1-4R0-J1	FUSE	1		
	9	LV42032-001A	AC BRACKET	1		
△	10	QMF51U1-8R0-J8	FUSE	2		
	11	QYSBSF3008Z	SCREW	2		
△	12	QHS3771-108	CORD STOPPER	1		
△	13	QMPD280-200-JC	POWER CORD	1	MOTHER TO H.BKT	
	14	QYSBSF3008Z	SCREW	7		
	15	LV31756-001A	VOLUME BRACKET	1		
	16	QYSBSF3008Z	SCREW	2	FOR BOLUME BKT	
	17	QYSBST3006Z	T.SCREW	2	FOR PUSH SW	
	18	E407321-002SM	PUSH BUTTON	1		
	19	QYSBSG3016Z	T.SCREW	8	FOR TRTO H/S	
	20	QYSBSG3008E	T.SCREW	4	MOTHER TO H/SBK	
△	21	LV20656-002A	HEAT SINK	1		
	22	LV20895-002A	REAR PANEL	1		
	23	QYSDSF3008M	SCREW	10	TO MOLD BASE	
	24	QYSBSGY3008E	SPECIAL SCREW	6	FOR H/S	
	25	E73562-003	SPECIAL SCREW	1	DIN.REAR	
	26	QYSBSGY3008E	SPECIAL SCREW	4	FOR SPK	
	27	LV20655-001A	H.S.COVER	1		
	28	QYSBSG3008M	T.SCREW	4		
	29	LV30734-002A	KNOB	1		
	30	QYSDSA4025M	T.SCREW	8		
	31	AA000020-02	CABI/SPK ASSY	1	JVC BRAND	
	32	CR200002-01	CONE SPEAKER	1		
	33	6100058411	CONN.WIRE ASSY	1		
	34	7005942502	SCREW	8		
	35	9925001311	SARAN BOARD	1	JVC MARK	
	36	5300014001	BAFFLE BOARD	1		
	37	6600007421	L.E.D.INDICATOR	1		
	38	7004690801	TAPPING SCREW	2		
	39	7005942502	SCREW	9		
	40	6000167301	CAUTION LABEL	1		
	41	LV31722-003A	P.TR HOLDER	1		
	42	LV31722-002A	P.TR HOLDER	1		

■ Electrical parts list (Main board)

Block No. 01

△	Item	Parts number	Parts name	Remarks	Area	△	Item	Parts number	Parts name	Remarks	Area
	C 601	QCBB1HK-181Y	C CAPACITOR	180PF 10% 50V			C1187	QETN1AM-107Z	E CAPACITOR	100MF 20% 10V	
	C 603	QCSB1HJ-680Y	C CAPACITOR	68PF 5% 50V			C1351	QETN1AM-107Z	E CAPACITOR	100MF 20% 10V	
	C 604	QCSB1HJ-150Y	C CAPACITOR	15PF 5% 50V			C1352	QETN1HM-106Z	E CAPACITOR	10MF 20% 50V	
	C 609	QETN0JM-477Z	E CAPACITOR	470MF 20% 6.3V			C1353	QETN1CM-107Z	E CAPACITOR	100MF 20% 16V	
	C 611	QCBB1HK-181Y	C CAPACITOR	180PF 10% 50V			C1801	QEKC1CM-106Z	E CAPACITOR	10MF 20% 16V	
	C 613	QCSB1HJ-680Y	C CAPACITOR	68PF 5% 50V			C1802	QEKC1CM-107Z	E.CAPACITOR	100MF 20% 16V	
	C 614	QCSB1HJ-150Y	C CAPACITOR	15PF 5% 50V			C1803	QCZ0205-155Z	ML C CAPACITOR	1.5MF	
	C 619	QETN0JM-477Z	E CAPACITOR	470MF 20% 6.3V			C1805	QCZ0205-155Z	ML C CAPACITOR	1.5MF	
	C 621	QCBB1HK-121Y	C CAPACITOR	120PF 10% 50V			D 609	1SS133-T2	SI DIODE		
	C 623	QCSB1HJ-470Y	C CAPACITOR	47PF 5% 50V			D 619	1SS133-T2	SI DIODE		
	C 624	QCSB1HJ-100Y	C CAPACITOR	10PF 5% 50V			D 629	1SS133-T2	SI DIODE		
	C 629	QETN0JM-477Z	E CAPACITOR	470MF 20% 6.3V			D 639	1SS133-T2	SI DIODE		
	C 631	QCBB1HK-121Y	C CAPACITOR	120PF 10% 50V			D 649	1SS133-T2	SI DIODE		
	C 633	QCSB1HJ-470Y	C CAPACITOR	47PF 5% 50V			D 659	1SS133-T2	SI DIODE		
	C 634	QCSB1HJ-100Y	C CAPACITOR	10PF 5% 50V			D 721	SELU1E56BM	LED	DISC LIGHT	
	C 639	QCFB1HZ-104Y	C CAPACITOR	.10MF +80:-20%			D 722	SELU1E56BM	LED	DISC LIGHT	
	C 641	QCBB1HK-121Y	C CAPACITOR	120PF 10% 50V			D 803	MTZJ6.2C-T2	Z DIODE I/M		
	C 643	QCSB1HJ-470Y	C CAPACITOR	47PF 5% 50V			D 807	1SS133-T2	SI DIODE		
	C 644	QCSB1HJ-100Y	C CAPACITOR	10PF 5% 50V			D 808	1SS133-T2	SI DIODE		
	C 649	QETN0JM-477Z	E CAPACITOR	470MF 20% 6.3V			D 809	1SS133-T2	SI DIODE		
	C 659	QETN0JM-477Z	E CAPACITOR	470MF 20% 6.3V			D 811	1SS133-T2	SI DIODE		
	C 661	QDGB1HK-102Y	C CAPACITOR				D 812	MTZJ4.7B-T2	Z DIODE I M		
	C 662	QCBB1HK-103Y	C CAPACITOR	.010MF 10% 50V			D 820	1SS133-T2	SI DIODE		
	C 721	QCBB1HK-103Y	C CAPACITOR	.010MF 10% 50V			D 871	1SS133-T2	SI DIODE		
	C 722	QCBB1HK-103Y	C CAPACITOR	.010MF 10% 50V			D1184	MTZJ7.5C-T2	ZENER DIODE		
	C 801	QCF31HZ-103Z	C CAPACITOR	.010MF +80:-20%			D1185	MTZJ7.5C-T2	ZENER DIODE		
	C 802	QCF31HZ-103Z	C CAPACITOR	.010MF +80:-20%			D1351	1SS133-T2	SI DIODE		
	C 804	QCBB1HK-221Y	C CAPACITOR	220PF 10% 50V			D1352	MTZJ6.8A-T2	ZENER DIODE		
	C 806	QEZ0229-479Z	EDL.CAPACITOR	47000MF			D1353	1SS133-T2	SI DIODE		
	C 807	QEKC0JM-227Z	E CAPACITOR	220MF 20% 6.3V			EP803	QNZ0136-001Z	EARTH PLATE		
	C 811	QCF31HZ-103Z	C CAPACITOR	.010MF +80:-20%			EP805	QNZ0136-001Z	EARTH PLATE		
	C 812	QCBB1HK-473Y	C CAPACITOR	.047MF 10% 50V			EP806	QNZ0136-001Z	EARTH PLATE		
	C 813	QEKC1AM-107Z	E.CAPACITOR	100MF 20% 10V			HS805	LE40505-001A	HEAT SINK	FOR IC805	
	C 814	QEKC1AM-107Z	E.CAPACITOR	100MF 20% 10V			IC108	TA8409S	IC	MOTOR DRIVER	
	C 815	QETN1CM-107Z	E CAPACITOR	100MF 20% 16V			IC801	MN101C49GHT1	IC	SYSTEM MICOM	
	C 816	QETN1AM-107Z	E CAPACITOR	100MF 20% 10V			IC803	IC-PST9140-T	IC	RESET	
	C 821	QDYB1CM-103Y	C.CAPACITOR				IC804	BR93LC46-W	IC	EEPROM	
	C 822	QETN1HM-225Z	E CAPACITOR	2.2MF 20% 50V			IC805	NJM78M05FA	IC	ASV	
	C 823	QDGB1HK-102Y	C CAPACITOR				J 601	QNN0017-002	PIN JACK	COMPOSITE	
	C 824	QDVB1EZ-223Y	C CAPACITOR				J 602	QND0019-001	S-CONNECTOR		
	C 826	QEKC1HM-224Z	E CAPACITOR	.22MF 20% 50V			J 603	QNN0386-001	PIN JACK	COMPONENT	
	C 828	QETN1AM-107Z	E CAPACITOR	100MF 20% 10V			J 802	QNS0083-001	3.5 JACK	AV COMPULINK 2	
	C 829	QETN1CM-107Z	E CAPACITOR	100MF 20% 16V			K 603	QQR0601-001Z	FERRITE BEADS		
	C 833	QDGB1HK-102Y	C CAPACITOR				K 605	QQR0601-001Z	FERRITE BEADS		
	C 835	QCBB1HK-101Y	C CAPACITOR	100PF 10% 50V			L 601	QQL071J-120Y	INDUCTOR		
	C 836	QCBB1HK-101Y	C CAPACITOR	100PF 10% 50V			L 602	QQL071J-5R6Y	INDUCTOR		
	C 837	QCF31HZ-103Z	C CAPACITOR	.010MF +80:-20%			L 611	QQL071J-120Y	INDUCTOR		
	CN106	QGA2501C1-02	2P CONNECTOR				L 612	QQL071J-5R6Y	INDUCTOR		
	CN601	QGB2027M3-10S	CONNECTOR	TO DVD MODULE			L 621	QQL071J-120Y	INDUCTOR		
	CN801	QGB2027M4-22S	CONNECTOR	TO DVD MODULE			L 622	QQL071J-5R6Y	INDUCTOR		
	CN802	QGB1216J1-08S	CONNECTOR	TO FRONT			L 631	QQL071J-120Y	INDUCTOR		
	CN803	QGB2027M3-10S	CONNECTOR	TO DVD MODULE			L 632	QQL071J-5R6Y	INDUCTOR		
	CN804	QGF1016C1-15	FFC CONNECTOR	TO AUDIO			L 641	QQL071J-120Y	INDUCTOR		
	CN805	QGF1205C1-15	CONNECTOR	TO TUNER			L 642	QQL071J-5R6Y	INDUCTOR		
	CN806	QGF1016C1-17	CONNECTOR	TO AUDIO			Q 601	KTA1267/YG/-T	TRANSISTOR		
	CN807	QGB2011MP-08	B TO B CONNE	TO POWER			Q 611	KTA1267/YG/-T	TRANSISTOR		
	CN808	QGB2011MP-08	B TO B CONNE	TO POWER			Q 621	KTA1267/YG/-T	TRANSISTOR		
	CN810	QGA2001C1-03	3P PLUG ASSY				Q 631	KTA1267/YG/-T	TRANSISTOR		
	CN811	QGA2001F1-02	2P CONNECTOR				Q 641	KTA1267/YG/-T	TRANSISTOR		
	CN812	QGA2001C1-03	3P PLUG ASSY				Q 712	KRC102M-T	D.TRANSISTOR		
	C1184	QETN1EM-476Z	E CAPACITOR	47MF 20% 25V			Q 801	KRC107M-T	D.TR.I.M		
	C1185	QETN1EM-476Z	E CAPACITOR	47MF 20% 25V			Q 802	KRC102M-T	D.TRANSISTOR		
	C1186	QETN1AM-107Z	E CAPACITOR	100MF 20% 10V			Q 804	KRC102M-T	D.TRANSISTOR		

■ Electrical parts list (Main board)

Block No. 01

△	Item	Parts number	Parts name	Remarks	Area
	Q 805	KTA1267/YG/-T	TRANSISTOR		
	Q 807	KRA102M-T	D.TRANSISTOR		
	Q 811	KRC102M-T	D.TRANSISTOR		
	Q 812	KTA1271/OY/-T	TRANSISTOR		
	Q 813	KRC104M-T	D.TR.I.M		
	Q 814	KTA1271/OY/-T	TRANSISTOR		
	Q 815	KRC102M-T	D.TRANSISTOR		
	Q 817	KTA1271/OY/-T	TRANSISTOR		
	Q 818	KRC111M-T	TR I/M		
	Q1181	KTC3203/OY/-T	TRANSISTOR	E.VOL +7V	
	Q1182	KTA1271/OY/-T	TRANSISTOR	E.VOL -7V	
	Q1351	KTC3203/OY/-T	TRANSISTOR	TUNER 5V	
	Q1801	KRC103M-T	TR I/M		
	R 601	QRE141J-0R0Y	C RESISTOR	5% 1/4W	
	R 602	QRE141J-391Y	C RESISTOR	390 5% 1/4W	
	R 603	QRE141J-0R0Y	C RESISTOR	5% 1/4W	
	R 604	QRE141J-391Y	C RESISTOR	390 5% 1/4W	
	R 605	QRE141J-221Y	C RESISTOR	220 5% 1/4W	
	R 606	QRE141J-102Y	C RESISTOR	1.0K 5% 1/4W	
	R 609	QRE141J-680Y	C RESISTOR	68 5% 1/4W	
	R 611	QRE141J-0R0Y	C RESISTOR	5% 1/4W	
	R 612	QRE141J-391Y	C RESISTOR	390 5% 1/4W	
	R 613	QRE141J-0R0Y	C RESISTOR	5% 1/4W	
	R 614	QRE141J-391Y	C RESISTOR	390 5% 1/4W	
	R 615	QRE141J-221Y	C RESISTOR	220 5% 1/4W	
	R 616	QRE141J-102Y	C RESISTOR	1.0K 5% 1/4W	
	R 619	QRE141J-680Y	C RESISTOR	68 5% 1/4W	
	R 621	QRE141J-751Y	C RESISTOR	750 5% 1/4W	
	R 622	QRE141J-751Y	C RESISTOR	750 5% 1/4W	
	R 623	QRE141J-751Y	C RESISTOR	750 5% 1/4W	
	R 624	QRE141J-751Y	C RESISTOR	750 5% 1/4W	
	R 625	QRE141J-221Y	C RESISTOR	220 5% 1/4W	
	R 626	QRE141J-561Y	C RESISTOR	560 5% 1/4W	
	R 629	QRE141J-680Y	C RESISTOR	68 5% 1/4W	
	R 631	QRE141J-0R0Y	C RESISTOR	5% 1/4W	
	R 632	QRE141J-361Y	C RESISTOR	360 5% 1/4W	
	R 633	QRE141J-0R0Y	C RESISTOR	5% 1/4W	
	R 634	QRE141J-361Y	C RESISTOR	360 5% 1/4W	
	R 635	QRE141J-221Y	C RESISTOR	220 5% 1/4W	
	R 636	QRE141J-102Y	C RESISTOR	1.0K 5% 1/4W	
	R 639	QRE141J-680Y	C RESISTOR	68 5% 1/4W	
	R 641	QRE141J-751Y	C RESISTOR	750 5% 1/4W	
	R 642	QRE141J-751Y	C RESISTOR	750 5% 1/4W	
	R 643	QRE141J-751Y	C RESISTOR	750 5% 1/4W	
	R 644	QRE141J-751Y	C RESISTOR	750 5% 1/4W	
	R 645	QRE141J-221Y	C RESISTOR	220 5% 1/4W	
	R 646	QRE141J-561Y	C RESISTOR	560 5% 1/4W	
	R 649	QRE141J-680Y	C RESISTOR	68 5% 1/4W	
	R 659	QRE141J-680Y	C RESISTOR	68 5% 1/4W	
	R 741	QRE141J-331Y	C RESISTOR	330 5% 1/4W	
	R 742	QRE141J-331Y	C RESISTOR	330 5% 1/4W	
	R 803	QRE141J-101Y	C RESISTOR	100 5% 1/4W	
	R 805	QRE141J-101Y	C RESISTOR	100 5% 1/4W	
	R 806	QRE141J-103Y	C RESISTOR	10K 5% 1/4W	
	R 811	QRE141J-101Y	C RESISTOR	100 5% 1/4W	
	R 813	QRE141J-331Y	C RESISTOR	330 5% 1/4W	
	R 816	QRE141J-104Y	C RESISTOR	100K 5% 1/4W	
	R 817	QRE141J-223Y	C RESISTOR	22K 5% 1/4W	
	R 818	QRE141J-472Y	C RESISTOR	4.7K 5% 1/4W	
	R 819	QRE141J-474Y	C RESISTOR	470K 5% 1/4W	
	R 821	QRZ9006-4R7X	F RESISTOR	4.7 1/0W	
	R 822	QRE141J-223Y	C RESISTOR	22K 5% 1/4W	
	R 823	QRE141J-223Y	C RESISTOR	22K 5% 1/4W	

△	Item	Parts number	Parts name	Remarks	Area
	R 831	QRE141J-103Y	C RESISTOR	10K 5% 1/4W	
	R 832	QRE141J-103Y	C RESISTOR	10K 5% 1/4W	
	R 833	QRE141J-103Y	C RESISTOR	10K 5% 1/4W	
	R 834	QRE141J-104Y	C RESISTOR	100K 5% 1/4W	
	R 835	QRE141J-104Y	C RESISTOR	100K 5% 1/4W	
	R 847	QRE141J-102Y	C RESISTOR	1.0K 5% 1/4W	
	R 848	QRE141J-102Y	C RESISTOR	1.0K 5% 1/4W	
	R 849	QRE141J-102Y	C RESISTOR	1.0K 5% 1/4W	
	R 850	QRE141J-221Y	C RESISTOR	220 5% 1/4W	
	R 851	QRE141J-221Y	C RESISTOR	220 5% 1/4W	
	R 861	QRE141J-102Y	C RESISTOR	1.0K 5% 1/4W	
	R 862	QRE141J-102Y	C RESISTOR	1.0K 5% 1/4W	
	R 863	QRE141J-102Y	C RESISTOR	1.0K 5% 1/4W	
	R 864	QRE141J-102Y	C RESISTOR	1.0K 5% 1/4W	
	R 865	QRE141J-102Y	C RESISTOR	1.0K 5% 1/4W	
	R 866	QRE141J-102Y	C RESISTOR	1.0K 5% 1/4W	
	R 871	QRE141J-332Y	C RESISTOR	3.3K 5% 1/4W	
	R 872	QRE141J-332Y	C RESISTOR	3.3K 5% 1/4W	
	R 873	QRE141J-332Y	C RESISTOR	3.3K 5% 1/4W	
	R 874	QRE141J-332Y	C RESISTOR	3.3K 5% 1/4W	
	R 875	QRE141J-332Y	C RESISTOR	3.3K 5% 1/4W	
	R 876	QRE141J-332Y	C RESISTOR	3.3K 5% 1/4W	
	R 891	QRE141J-181Y	C RESISTOR	180 5% 1/4W	
	R 892	QRE141J-151Y	C RESISTOR	150 5% 1/4W	
	R 895	QRE141J-102Y	C RESISTOR	1.0K 5% 1/4W	
	R 896	QRE141J-103Y	C RESISTOR	10K 5% 1/4W	
	R1181	QRZ9005-100X	F.RES I/M	10 1/0W	
	R1182	QRE141J-222Y	C RESISTOR	2.2K 5% 1/4W	
	R1183	QRE141J-222Y	C RESISTOR	2.2K 5% 1/4W	
	R1184	QRZ9005-100X	F.RES I/M	10 1/0W	
	R1301	QRE141J-682Y	C RESISTOR	6.8K 5% 1/4W	
	R1302	QRE141J-682Y	C RESISTOR	6.8K 5% 1/4W	
	R1303	QRE141J-102Y	C RESISTOR	1.0K 5% 1/4W	
	R1304	QRE141J-102Y	C RESISTOR	1.0K 5% 1/4W	
	R1305	QRE141J-103Y	C RESISTOR	10K 5% 1/4W	
	R1306	QRE141J-103Y	C RESISTOR	10K 5% 1/4W	
	R1351	QRZ9006-4R7X	F RESISTOR	4.7 1/0W	
	R1352	QRE141J-102Y	C RESISTOR	1.0K 5% 1/4W	
	R1802	QRE141J-153Y	C RESISTOR	15K 5% 1/4W	
	R1803	QRE141J-473Y	C RESISTOR	47K 5% 1/4W	
	R1804	QRE141J-6R2Y	C RESISTOR	6.2 5% 1/4W	
	R1806	QRE141J-183Y	C RESISTOR	18K 5% 1/4W	
	R1807	QRE141J-151Y	C RESISTOR	150 5% 1/4W	
	SP801	VYH7237-002SC	IC HOLDER	FOR IC801	
	S8021	QSW0851-001	DETECT SWITCH	DOOR SW(DOOR1/2)	
	S8022	QSW0851-001	DETECT SWITCH	DOOR SW(DOOR3)	
	W 810	QJK018-032102	SIN CR C-B WIRE	TO CN810	
	W 811	QJK018-020602	SIN CR C-B WIRE	TO CN811	
	W 812	QJK018-032602	SIN CR C-B WIRE	TO CN812	
	X 801	QAX0246-001Z	RESONATOR I.M	8MHZ	

■ Electrical parts list (Front&sply board) Block No. 02

△	Item	Parts number	Parts name	Remarks	Area
	BK701	LV32331-001A	FL HOLDER		
	BK901	E409182-001SM	GRAND TERMINAL		
	BK902	E409182-001SM	GRAND TERMINAL		
	C 701	QDYB1CM-103Y	C.CAPACITOR		
	C 702	QCBB1HK-471Y	C CAPACITOR	470PF 10% 50V	
	C 703	QCBB1HK-471Y	C CAPACITOR	470PF 10% 50V	
	C 704	QCBB1HK-471Y	C CAPACITOR	470PF 10% 50V	
	C 705	QCBB1HK-471Y	C CAPACITOR	470PF 10% 50V	
	C 706	QERF0JM-107Z	E CAPACITOR	100MF 20% 6.3V	
	C 707	QDYB1CM-103Y	C.CAPACITOR		
	C 708	QDYB1CM-103Y	C.CAPACITOR		
	C 709	QERF1HM-475Z	E CAPACITOR	4.7MF 20% 50V	
	C 710	QERF1HM-475Z	E CAPACITOR	4.7MF 20% 50V	
	C 733	QERF0JM-226Z	E CAPACITOR	22MF 20% 6.3V	
△	C 902	QFZ9075-683	M CAPACITOR	.068MF	
	C 904	QCZ9079-102	C CAPACITOR	1000PF	
	C 905	QCZ9079-102	C CAPACITOR	1000PF	
△	C 907	QETM2DM-157	E CAPACITOR	150MF 20%	
	C 908	QCZ0136-332Z	C CAPACITOR	3300PF	
	C 909	QCZ0136-101Z	C CAPACITOR	100PF	
	C 910	QCBB1HK-221Y	C CAPACITOR	220PF 10% 50V	
	C 913	QCZ0136-101Z	C CAPACITOR	100PF	
	C 914	QEMX1EM-396Z	E CAPACITOR	39MF 20% 25V	
	C 915	QCBB1HK-471Y	C CAPACITOR	470PF 10% 50V	
△	C 916	QCZ9079-332	C CAPACITOR	3300PF	
	C 918	QCFB1HZ-104Y	C CAPACITOR	.10MF +80:-20%	
	C 951	QCBB1HK-101Y	C CAPACITOR	100PF 10% 50V	
	C 952	QCZ0136-101Z	C CAPACITOR	100PF	
	C 953	QCBB1HK-101Y	C CAPACITOR	100PF 10% 50V	
	C 954	QCBB1HK-101Y	C CAPACITOR	100PF 10% 50V	
	C 956	QCBB1HK-101Y	C CAPACITOR	100PF 10% 50V	
	C 957	QCBB1HK-101Y	C CAPACITOR	100PF 10% 50V	
	C 960	QEMX1AM-826Z	E CAPACITOR	82MF 20% 10V	
	C 961	QCZ0205-155Z	ML C CAPACITOR	1.5MF	
	C 962	QETN1HM-226Z	E CAPACITOR	22MF 20% 50V	
	C 963	QEMX1HM-396Z	E CAPACITOR	39MF 20% 50V	
	C 964	QETN1HM-226Z	E CAPACITOR	22MF 20% 50V	
	C 965	QEMV1AM-108	E CAPACITOR	1000MF 20% 10V	
	C 966	QETN1AM-477Z	E CAPACITOR	470MF 20% 10V	
	C 967	QFVC1HJ-104Z	M.M.CAPACITOR	.10MF 5% 50V	
	C 968	QFVC1HJ-104Z	M.M.CAPACITOR	.10MF 5% 50V	
	C 969	QETN1AM-227Z	E CAPACITOR	220MF 20% 10V	
	C 970	QFVC1HJ-104Z	M.M.CAPACITOR	.10MF 5% 50V	
	C 973	QETN1AM-107Z	E CAPACITOR	100MF 20% 10V	
	C 976	QFVC1HJ-104Z	M.M.CAPACITOR	.10MF 5% 50V	
	C 977	QFVC1HJ-104Z	M.M.CAPACITOR	.10MF 5% 50V	
	C 978	QETN1AM-107Z	E CAPACITOR	100MF 20% 10V	
	C 979	QEMV1CM-827	E CAPACITOR	820MF 20% 16V	
	C 980	QETN1HM-106Z	E CAPACITOR	10MF 20% 50V	
	C 981	QCZ0205-155Z	ML C CAPACITOR	1.5MF	
	C 982	QEMV1EM-567	E CAPACITOR	560MF 20% 25V	
	C 984	QETN1EM-227Z	E CAPACITOR	220MF 20% 25V	
	C 985	QETN1EM-107Z	E CAPACITOR	100MF 20% 25V	
	C 986	QETN1EM-107Z	E CAPACITOR	100MF 20% 25V	
	C 987	QEMX1EM-187Z	E CAPACITOR	180MF 20% 25V	
	C 989	QETN1EM-107Z	E CAPACITOR	100MF 20% 25V	
	C 990	QETN1HM-106Z	E CAPACITOR	10MF 20% 50V	
	C 992	QETN1HM-474Z	E CAPACITOR	.47MF 20% 50V	
	C 993	QCBB1HK-101Y	C CAPACITOR	100PF 10% 50V	
	C 994	QDVB1EZ-223Y	C CAPACITOR		
	C 997	QETN1CM-227Z	E CAPACITOR	220MF 20% 16V	
	CN701	QGB1216K1-06S	CONNECTOR	FRONT TO POWER	
	CN702	QGB1216K1-08S	CONNECTOR	FRONT TO MAIN	

△	Item	Parts number	Parts name	Remarks	Area
	CN951	QGB2011L1-08	B TO B CONNECTO	TO CN705(SYS)	
	CN961	QGB2011L1-08	B TO B CONNECTO	TO CN704(SYS)	
	CN971	QGB1216J1-06S	CONNECTOR	TO CN832(FL)	
	CN972	QGA2001C1-02	2P PLUG ASSY	FOR DC FAN	
	CN981	QGB2510J1-04	CONNECTOR		
	CN982	QGB2510J1-04	CONNECTOR		
	CN983	QGB2510K2-04	CONNECTOR		
	CN984	QGB2510K2-04	CONNECTOR		
△	CP951	ICP-N10-T	ICP		
△	CP952	ICP-N5-T	ICP		
△	CP953	QAD0109-R90Z	POG I.M		
△	CP954	QAD0109-R90Z	POG I.M		
	D 701	1SS133-T2	SI DIODE		
	D 702	1SS133-T2	SI DIODE		
	D 703	1SS133-T2	SI DIODE		
	D 713	1SS133-T2	SI DIODE		
	D 733	SLR-342VC-T12	LED	H=11.9	
△	D 901	S1WB/A/60-4101	BRIDGE DIODE		
	D 902	ERA18-04-T1	FR DIODE		
	D 903	ERA18-04-T1	FR DIODE		
	D 904	ERA18-04-T1	FR DIODE		
	D 908	ERA18-04-T1	FR DIODE		
	D 910	ERA18-04-T1	FR DIODE		
	D 911	ERA18-04-T1	FR DIODE		
	D 950	MTZJ36C-T2	Z.DIODE I.M		
	D 951	ERA18-04-T1	FR DIODE		
	D 952	ERA18-04-T1	FR DIODE		
△	D 953	FMB-24	FUSEIODE		
△	D 954	ERA18-04-T1	FR DIODE		
△	D 956	ERA18-04-T1	FR DIODE		
△	D 957	ERA18-04-T1	FR DIODE		
	D 958	1SS133-T2	SI DIODE		
	D 960	MTZJ3.6B-T2	S.B.DIODE		
	D 970	1SS133-T2	SI DIODE		
	D 975	1SS133-T2	SI DIODE		
	D 976	1SS133-T2	SI DIODE		
	D 982	1SS133-T2	SI DIODE		
	D 983	1SS133-T2	SI DIODE		
	D 991	MTZJ5.1C-T2	ZENER DIODE		
	DI701	QLF0080-001	FL TUBE		
	FC901	QNG0003-001Z	FUSE CLIP		
	FC902	QNG0003-001Z	FUSE CLIP		
	HS901	E70306-002	HEAT SINK	FOR IC901	
	HS964	LE40505-001A	HEAT SINK		
	IC701	MN173222DG	IC	DISPLAY MICOM	
	IC711	GP1U271X	RM RECIVER	REMOCON	
	IC901	STR-G6651	IC		
	IC951	PQ05RD21	IC		
	IC953	NJM78M05FA	IC		
	K 902	QQR0779-001Z	INDUCTOR		
△	L 901	QQR1105-001	LINE FILTER		
	L 951	QQL01BK-R22Z	I0COIL		
	L 952	QQR1098-001	INDUCTOR		
	L 955	QQR1098-001	INDUCTOR		
	L 957	QQR1098-001	INDUCTOR		
	L 959	QQR1098-001	INDUCTOR		
△	P 901	QNC0046-001	AC INLET		
△	PC901	PC123Y02	IC(PHOTO COUPLE		
△	PC902	PC123Y02	IC(PHOTO COUPLE		
	PP903	QZW0038-001	WIRE CLAMP		
	PP904	QZW0038-001	WIRE CLAMP		
	Q 703	KRC103M-T	TR I/M		
	Q 706	KRA102M-T	D.TRANSISTOR		

■ Electrical parts list (Front&sply board)

Block No. 02

△	Item	Parts number	Parts name	Remarks	Area
	Q 707	KRA102M-T	D.TRANSISTOR		
	Q 708	KRA102M-T	D.TRANSISTOR		
	Q 709	KRA102M-T	D.TRANSISTOR		
	Q 710	KRC102M-T	D.TRANSISTOR		
	Q 711	KRC102M-T	D.TRANSISTOR		
	Q 951	2SC3576-JVC-T	TRANSISTOR I/M		
	Q 953	KTA1267/YG/-T	TRANSISTOR		
	Q 954	2SJ537-T	MOS FET I/M		
	Q 955	KRA103M-T	TRANSISTOR *		
	Q 956	2SJ537-T	MOS FET I/M		
	Q 957	KRC103M-T	TR I/M		
	Q 958	KTA1271/OY/-T	TRANSISTOR		
	Q 959	KRC103M-T	TR I/M		
	Q 960	KTA1267/YG/-T	TRANSISTOR		
	Q 961	KTC3203/OY/-T	TRANSISTOR		
	Q 964	KTA1046/Y/	TRANSISTOR		
	Q 965	KTC3199/GL/-T	TRANSISTOR		
	Q 991	KTC3199/GL/-T	TRANSISTOR		
	R 701	QRE141J-102Y	C RESISTOR	1.0K 5% 1/4W	
	R 702	QRE141J-102Y	C RESISTOR	1.0K 5% 1/4W	
	R 703	QRE141J-102Y	C RESISTOR	1.0K 5% 1/4W	
	R 704	QRE141J-102Y	C RESISTOR	1.0K 5% 1/4W	
	R 705	QRE141J-102Y	C RESISTOR	1.0K 5% 1/4W	
	R 707	QRE141J-103Y	C RESISTOR	10K 5% 1/4W	
	R 708	QRE141J-103Y	C RESISTOR	10K 5% 1/4W	
	R 709	QRE141J-103Y	C RESISTOR	10K 5% 1/4W	
	R 710	QRE141J-103Y	C RESISTOR	10K 5% 1/4W	
	R 711	QRE141J-223Y	C RESISTOR	22K 5% 1/4W	
	R 712	QRE141J-102Y	C RESISTOR	1.0K 5% 1/4W	
	R 713	QRE141J-104Y	C RESISTOR	100K 5% 1/4W	
	R 714	QRE141J-104Y	C RESISTOR	100K 5% 1/4W	
	R 715	QRE141J-104Y	C RESISTOR	100K 5% 1/4W	
	R 716	QRE141J-104Y	C RESISTOR	100K 5% 1/4W	
	R 724	QRE141J-221Y	C RESISTOR	220 5% 1/4W	
	R 725	QRE141J-103Y	C RESISTOR	10K 5% 1/4W	
	R 751	QRE141J-221Y	C RESISTOR	220 5% 1/4W	
	R 756	QRE141J-103Y	C RESISTOR	10K 5% 1/4W	
	R 901	QRL01DJ-683X	OMF RESISTOR	68K 5% 1/1W	
	R 903	QRE141J-270Y	C RESISTOR	27 5% 1/4W	
	R 904	QRE141J-222Y	C RESISTOR	2.2K 5% 1/4W	
	R 905	QRL027J-683	OMF RESISTOR	68K 5% 1/2W	
	R 906	QRJ146J-681X	UNF C.RES I/M	680 5% 1/4W	
	R 907	QRT022J-R47	OMF RESISTOR	5% 1/2W	
	R 908	QRE141J-332Y	C RESISTOR	3.3K 5% 1/4W	
	R 910	QRE141J-754Y	C RESISTOR	750K 5% 1/4W	
	R 911	QRE141J-754Y	C RESISTOR	750K 5% 1/4W	
	R 921	QRZ9044-335	COMP.RESISTOR	FOR C/J ONLY	
	R 952	QRE141J-103Y	C RESISTOR	10K 5% 1/4W	
	R 953	QRE141J-223Y	C RESISTOR	22K 5% 1/4W	
△	R 954	QRZ9005-100X	F.RES I/M	10 1/0W	
	R 955	QRE141J-223Y	C RESISTOR	22K 5% 1/4W	
	R 960	QRE141J-101Y	C RESISTOR	100 5% 1/4W	
	R 961	QRE141J-681Y	C RESISTOR	680 5% 1/4W	
	R 962	QRE141J-105Y	C RESISTOR	1.0M 5% 1/4W	
	R 963	QRE141J-101Y	C RESISTOR	100 5% 1/4W	
	R 964	QRE141J-105Y	C RESISTOR	1.0M 5% 1/4W	
	R 965	QRE141J-103Y	C RESISTOR	10K 5% 1/4W	
	R 966	QRE141J-221Y	C RESISTOR	220 5% 1/4W	
	R 969	QRE141J-221Y	C RESISTOR	220 5% 1/4W	
	R 971	QRE141J-472Y	C RESISTOR	4.7K 5% 1/4W	
	R 972	QRE141J-122Y	C RESISTOR	1.2K 5% 1/4W	
	R 977	QRE141J-102Y	C RESISTOR	1.0K 5% 1/4W	
	R 980	QRE141J-272Y	C RESISTOR	2.7K 5% 1/4W	

△	Item	Parts number	Parts name	Remarks	Area
	R 981	QRE141J-223Y	C RESISTOR	22K 5% 1/4W	
	R 982	QRE141J-332Y	C RESISTOR	3.3K 5% 1/4W	
	R 983	QRE141J-102Y	C RESISTOR	1.0K 5% 1/4W	
	R 984	QRE141J-102Y	C RESISTOR	1.0K 5% 1/4W	
	R 985	QRE141J-102Y	C RESISTOR	1.0K 5% 1/4W	
	R 986	QRE141J-102Y	C RESISTOR	1.0K 5% 1/4W	
	R 987	QRE141J-102Y	C RESISTOR	1.0K 5% 1/4W	
	R 988	QRE141J-222Y	C RESISTOR	2.2K 5% 1/4W	
	R 989	QRE141J-333Y	C RESISTOR	33K 5% 1/4W	
	R 990	QRE141J-333Y	C RESISTOR	33K 5% 1/4W	
	R 991	QRE141J-103Y	C RESISTOR	10K 5% 1/4W	
	R 992	QRE141J-332Y	C RESISTOR	3.3K 5% 1/4W	
	S 701	QSW0683-001Z	PUSH SWITCH	PLAY	
	S 702	QSW0683-001Z	PUSH SWITCH	PAUSE	
	S 703	QSW0683-001Z	PUSH SWITCH	STOP	
	S 704	QSW0683-001Z	PUSH SWITCH	B.SKIP	
	S 705	QSW0683-001Z	PUSH SWITCH	F.SKIP	
	S 706	QSW0683-001Z	PUSH SWITCH	SOURCE	
	S 707	QSW0683-001Z	PUSH SWITCH	DOLBY	
	S 708	QSW0683-001Z	PUSH SWITCH	DSP	
	S 709	QSW0683-001Z	PUSH SWITCH	VOL.DOWN	
	S 710	QSW0683-001Z	PUSH SWITCH	VOL.UP	
	S 711	QSW0683-001Z	PUSH SWITCH	EJECT	
	S 712	QSW0683-001Z	PUSH SWITCH	POWER	
	SP701	VYH7237-005	IC HOLDER	FOR IC701	
△	T 901	QQS0097-001	SW TRANSF	DELTA ELECTRONI	
	X 701	QAX0247-001Z	RESONATOR I.M	6MHZ	

■ Electrical parts list (DSP&audio board)

Block No. 03

△	Item	Parts number	Parts name	Remarks	Area
	C 401	NCB31HK-102X	C CAPACITOR		
	C 402	NCB31HK-102X	C CAPACITOR		
	C 403	NEA70JM-476X	E.CAPACITOR		
	C 404	NEA70JM-476X	E.CAPACITOR		
	C 405	NCB31CK-104X	C CAPACITOR		
	C 406	NCB31CK-104X	C CAPACITOR		
	C 407	NCB31CK-104X	C CAPACITOR		
	C 408	NEA70JM-476X	E.CAPACITOR		
	C 421	NEA70JM-107X	E.CAPACITOR		
	C 422	NCB31CK-103X	C CAPACITOR		
	C 423	NCS31HJ-101X	C.CAPACITOR		
	C 424	NCS31HJ-121X	C CAPACITOR		
	C 425	NCB31AK-474X	C CAPACITOR		
	C 426	NCB31CK-103X	C CAPACITOR		
	C 427	NCB31CK-104X	C CAPACITOR		
	C 428	NCB31CK-104X	C CAPACITOR		
	C 429	NCB31CK-104X	C CAPACITOR		
	C 430	NCB31CK-473X	C CAPACITOR		
	C 431	NCS31HJ-180X	C CAPACITOR		
	C 432	NCS31HJ-220X	C CAPACITOR		
	C 433	NCB31CK-103X	C CAPACITOR		
	C 434	NEA70JM-107X	E.CAPACITOR		
	C 435	NCB31CK-103X	C CAPACITOR		
	C 436	NEA70JM-476X	E.CAPACITOR		
	C 442	NCB31HK-101X	C CAPACITOR		
	C 443	NCB31HK-101X	C CAPACITOR		
	C 444	NCB31CK-103X	C CAPACITOR		
	C 445	NEA70JM-107X	E.CAPACITOR		
	C 451	NCB31CK-103X	C CAPACITOR		
	C 452	NEA70JM-107X	E.CAPACITOR		
	C 453	NEA70JM-107X	E.CAPACITOR		
	C 454	NCB31CK-103X	C CAPACITOR		
	C 455	NEA70JM-107X	E.CAPACITOR		
	C 456	NCB31CK-104X	C CAPACITOR		
	C 458	NCB31CK-103X	C CAPACITOR		
	C 459	NCB31CK-103X	C CAPACITOR		
	C 460	NEA71CM-476X	E CAPACITOR		
	C 461	NEA71CM-476X	E CAPACITOR		
	C 462	NCB31CK-103X	C CAPACITOR		
	C 463	NEA70JM-107X	E.CAPACITOR		
	C 466	NEA71CM-476X	E CAPACITOR		
	C 467	NCF31CZ-104X	C CAPACITOR		
	C 493	NCB30JK-105X	C CAPACITOR		
	C 494	NCB31CK-103X	C CAPACITOR		
	C 495	NCB31CK-103X	C CAPACITOR		
	CN401	QGF1016F2-17W	CONNECTOR		
	CN402	QGF1016F2-15W	CONNECTOR C.M		
	C1101	NCB31HK-331X	C CAPACITOR		
	C1102	NCB31HK-331X	C CAPACITOR		
	C1103	NEA71EM-475X	E.CAPACITOR.		
	C1104	NEA71EM-475X	E.CAPACITOR.		
	C1121	NCB31CK-223X	C CAPACITOR		
	C1122	NCB31HK-822X	C CAPACITOR		
	C1123	NCB31HK-153X	C CAPACITOR		
	C1124	NCB21CK-334X	C CAPACITOR		
	C1125	NCB31CK-223X	C CAPACITOR		
	C1126	NCB31CK-223X	C CAPACITOR		
	C1127	NEA71EM-475X	E.CAPACITOR.		
	C1128	NEA71EM-475X	E.CAPACITOR.		
	C1129	NCB31HK-822X	C CAPACITOR		
	C1130	NCB31HK-153X	C CAPACITOR		
	C1131	NCB21CK-334X	C CAPACITOR		
	C1141	NEA71CM-476X	E CAPACITOR		

△	Item	Parts number	Parts name	Remarks	Area
	C1142	NEA71CM-476X	E CAPACITOR		
	C1176	NCB31CK-103X	C CAPACITOR		
	C1177	NCB31CK-103X	C CAPACITOR		
	C1178	NCB31CK-103X	C CAPACITOR		
	C1179	NCB31CK-103X	C CAPACITOR		
	C1180	NCB31CK-103X	C CAPACITOR		
	C1181	NCB31CK-103X	C CAPACITOR		
	C1183	NEA71EM-475X	E.CAPACITOR.		
	C1201	NEA71EM-475X	E.CAPACITOR.		
	C1202	NEA71EM-475X	E.CAPACITOR.		
	C1203	NEA71EM-475X	E.CAPACITOR.		
	C1204	NEA71EM-475X	E.CAPACITOR.		
	C1205	NEA71EM-475X	E.CAPACITOR.		
	C1206	NEA71EM-475X	E.CAPACITOR.		
	C1207	NEA71EM-475X	E.CAPACITOR.		
	C1208	NEA71EM-475X	E.CAPACITOR.		
	C1209	NEA71EM-475X	E.CAPACITOR.		
	C1210	NEA71EM-475X	E.CAPACITOR.		
	C1211	NEA71EM-475X	E.CAPACITOR.		
	C1212	NEA71EM-475X	E.CAPACITOR.		
	C1213	NEA71EM-475X	E.CAPACITOR.		
	C1214	NEA71EM-475X	E.CAPACITOR.		
	C1215	NEA71EM-475X	E.CAPACITOR.		
	C1216	NEA71EM-475X	E.CAPACITOR.		
	C1217	NEA71EM-475X	E.CAPACITOR.		
	C1218	NEA71EM-475X	E.CAPACITOR.		
	C1221	NCS31HJ-470X	C CAPACITOR		
	C1222	NCS31HJ-470X	C CAPACITOR		
	C1223	NCS31HJ-470X	C CAPACITOR		
	C1224	NCS31HJ-470X	C CAPACITOR		
	C1225	NCS31HJ-471X	C CAPACITOR		
	C1226	NCS31HJ-470X	C CAPACITOR		
	C1251	NCB31CK-103X	C CAPACITOR		
	C1252	NCB31CK-103X	C CAPACITOR		
	C2501	NCB31AK-474X	C CAPACITOR		
	C2503	NEA71EM-475X	E.CAPACITOR.		
	C2504	NEA71EM-475X	E.CAPACITOR.		
	C2505	NCS31HJ-560X	C CAPACITOR		
	C2506	NCS31HJ-560X	C CAPACITOR		
	C2507	NCS31HJ-560X	C CAPACITOR		
	C2508	NCS31HJ-560X	C CAPACITOR		
	C2509	NCF31CZ-104X	C CAPACITOR		
	C2510	NCF31CZ-104X	C CAPACITOR		
	C2511	NCB31AK-474X	C CAPACITOR		
	C2512	NCB31AK-474X	C CAPACITOR		
	C2513	NCB31CK-183X	C CAPACITOR		
	C2514	NCB31CK-183X	C CAPACITOR		
	C2515	NCB31HK-182X	C CAPACITOR		
	C2516	NCB31HK-182X	C CAPACITOR		
	C2517	NCB31HK-562X	C CAPACITOR		
	C2518	NCB31HK-562X	C CAPACITOR		
	C2519	NCF31CZ-104X	C CAPACITOR		
	C2520	NCF31CZ-104X	C CAPACITOR		
	C2521	NFV41CJ-103X	M CAPACITOR		
	C2522	NFV41CJ-103X	M CAPACITOR		
	C2523	NFV41HJ-272X	M CAPA C.M		
	C2524	NFV41HJ-272X	M CAPA C.M		
	C2525	NFV41CJ-392X	M CAPA C.M		
	C2526	NFV41CJ-392X	M CAPA C.M		
	C2527	NEA71EM-475X	E.CAPACITOR.		
	C2528	NEA71EM-475X	E.CAPACITOR.		
	C2529	NCF31CZ-104X	C CAPACITOR		
	C2530	NCF31CZ-104X	C CAPACITOR		

■ Electrical parts list (DSP&audio board)

Block No. 03

△	Item	Parts number	Parts name	Remarks	Area	△	Item	Parts number	Parts name	Remarks	Area
	C2531	NCS31HJ-560X	C CAPACITOR				IC511	BA15218F-XE	IC	AUX IN	
	C2532	NCS31HJ-560X	C CAPACITOR				IC521	BA15218F-XE	IC	L/R OUT	
	C2533	NEA71HM-105X	E.CAPA. C.M.				IC531	BA15218F-XE	IC	L/R OUT	
	C2534	NEA71HM-105X	E.CAPA. C.M.				IC561	BA15218F-XE	IC	SL/SR OUT	
	C2539	NCF31CZ-104X	C CAPACITOR				IC571	BA15218F-XE	IC	SL/SR OUT	
	C2540	NCF31CZ-104X	C CAPACITOR				IC581	BA15218F-XE	IC	C/LFE OUT	
	C2541	NEA71EM-475X	E.CAPACITOR.				IC591	BA15218F-XE	IC	C/LFE OUT	
	C2542	NEA71EM-475X	E.CAPACITOR.				J1101	QNN0385-001	PIN JACK ASSY	AUX IN	
	C2553	NCB31HK-562X	C CAPACITOR				J1103	QND0079-001	DIN CONNECTOR	SYSTEM CONECT	
	C2554	NCB31HK-562X	C CAPACITOR				K 401	NQR0319-001X	F.BEADS C.M		
	C2555	NCF31CZ-104X	C CAPACITOR				LC401	NQR0321-001X	EMI FILTER C.M		
	C2556	NCF31CZ-104X	C CAPACITOR				Q 401	DTA144EKA-X	TRANSISTOR		
	C2561	NEA71HM-105X	E.CAPA. C.M.				Q 402	DTC114YE-X	TRANSISTOR		
	C2562	NEA71HM-105X	E.CAPA. C.M.				Q 403	DTC114YE-X	TRANSISTOR		
	C2563	NCS31HJ-220X	C CAPACITOR				Q1131	IMX9-W	TRANSISTOR		
	C2564	NCS31HJ-220X	C CAPACITOR				Q1133	IMX9-W	TRANSISTOR		
	C2569	NCF31CZ-104X	C CAPACITOR				Q1135	IMX9-W	TRANSISTOR		
	C2570	NCF31CZ-104X	C CAPACITOR				Q1137	2SD2114K/VW-X	CHIP TRANSISTOR		
	C2571	NCB31CK-103X	C CAPACITOR				Q1251	DTA144EKA-X	TRANSISTOR		
	C2572	NCB31CK-103X	C CAPACITOR				Q1252	DTA144EKA-X	TRANSISTOR		
	C2573	NCB31HK-272X	C CAPACITOR				Q2501	DTA144EKA-X	TRANSISTOR		
	C2574	NCB31HK-272X	C CAPACITOR				Q2502	DTC144EKA-X	TRANSISTOR		
	C2575	NCB31HK-392X	C CAPACITOR				Q2521	IMX9-W	TRANSISTOR		
	C2576	NCB31HK-392X	C CAPACITOR				Q2561	IMX9-W	TRANSISTOR		
	C2577	NEA71EM-475X	E.CAPACITOR.				Q2581	IMX9-W	TRANSISTOR		
	C2578	NEA71EM-475X	E.CAPACITOR.				R 401	NRSA63J-473X	MG RESISTOR		
	C2579	NCF31CZ-104X	C CAPACITOR				R 402	NRSA63J-473X	MG RESISTOR		
	C2580	NCF31CZ-104X	C CAPACITOR				R 403	NRSA63J-221X	MG RESISTOR		
	C2581	NEA71HM-105X	E.CAPA. C.M.				R 404	NRSA63J-221X	MG RESISTOR		
	C2582	NEA71CM-106X	E.CAPACITOR				R 405	NRSA63J-221X	MG RESISTOR		
	C2583	NCS31HJ-220X	C CAPACITOR				R 406	NRSA63J-221X	MG RESISTOR		
	C2584	NCS31HJ-560X	C CAPACITOR				R 407	NRSA63J-221X	MG RESISTOR		
	C2589	NCF31CZ-104X	C CAPACITOR				R 408	NRSA63J-221X	MG RESISTOR		
	C2590	NCF31CZ-104X	C CAPACITOR				R 409	NRSA63J-473X	MG RESISTOR		
	C2591	NCB31CK-103X	C CAPACITOR				R 411	NRSA63J-473X	MG RESISTOR		
	C2592	NCB31HK-223X	C CAPACITOR				R 412	NRSA63J-473X	MG RESISTOR		
	C2593	NCB31HK-272X	C CAPACITOR				R 413	NRSA63J-822X	MG RESISTOR		
	C2594	NCB31CK-104X	C CAPACITOR				R 414	NRSA63J-432X	MG RESISTOR		
	C2595	NCB31HK-392X	C CAPACITOR				R 415	NRSA63J-221X	MG RESISTOR		
	C2597	NEA71EM-475X	E.CAPACITOR.				R 423	NRSA63J-102X	MG RESISTOR		
	C2598	NEA71EM-475X	E.CAPACITOR.				R 424	NRSA63J-563X	MG RESISTOR		
	C2599	NCF31CZ-104X	C CAPACITOR				R 425	NRSA63J-102X	MG RESISTOR		
	C2600	NCF31CZ-104X	C CAPACITOR				R 426	NRSA63J-103X	MG RESISTOR		
	C2601	NEA71EM-475X	E.CAPACITOR.				R 427	NRSA63J-103X	MG RESISTOR		
	C2602	NEA71EM-475X	E.CAPACITOR.				R 428	NRSA63J-472X	MG RESISTOR		
	C2603	NEA71EM-475X	E.CAPACITOR.				R 429	NRSA63J-101X	MG RESISTOR		
	C2604	NEA71EM-475X	E.CAPACITOR.				R 430	NRSA63J-103X	MG RESISTOR		
	D 401	DAN202K-X	D.TRANSISTOR				R 431	NRSA63J-225X	MG RESISTOR		
	D 403	DAN202K-X	D.TRANSISTOR				R 432	NRSA63J-472X	MG RESISTOR		
	D 405	DAN202K-X	D.TRANSISTOR				R 441	NRSA63J-221X	MG RESISTOR		
	IC151	BU4066BCF-X	IC	INPUT SELECT			R 442	NRSA63J-221X	MG RESISTOR		
	IC153	M62446FP-X	IC	E.VOLUME			R 443	NRSA63J-221X	MG RESISTOR		
	IC158	NJM4580M-X	IC	L/R OUT			R 444	NRSA63J-221X	MG RESISTOR		
	IC159	NJM4580M-X	IC	SL/SR OUT			R 445	NRSA63J-221X	MG RESISTOR		
	IC160	NJM4580M-X	IC	C/LFE OUT			R 446	NRSA63J-221X	MG RESISTOR		
	IC401	AK4527VQ	IC	CODEC			R 447	NRSA63J-221X	MG RESISTOR		
	IC402	RN5R233BA-X	IC				R 448	NRSA63J-221X	MG RESISTOR		
	IC403	TC9446F-014	IC	DSP			R 449	NRSA63J-221X	MG RESISTOR		
	IC404	AS7C31025-15TJX	IC	SRAM			R 450	NRSA63J-221X	MG RESISTOR		
	IC406	UPD784215AGC103	IC	DSP MICOM			R 451	NRSA63J-103X	MG RESISTOR		
	IC407	PQ3D253-X	IC	D3.3V REG			R 452	NRSA63J-432X	MG RESISTOR		
	IC501	BA15218F-XE	IC	AUX IN			R 453	NRSA63J-432X	MG RESISTOR		
	IC510	BA15218F-XE	IC	AUX IN			R 454	NRSA63J-432X	MG RESISTOR		

■ Electrical parts list (DSP&audio board)

Block No. 03

△	Item	Parts number	Parts name	Remarks	Area	△	Item	Parts number	Parts name	Remarks	Area
	R 455	NRSA63J-822X	MG RESISTOR				R1168	NRSA63J-332X	MG RESISTOR		
	R 456	NRSA63J-822X	MG RESISTOR				R1169	NRSA63J-393X	MG RESISTOR		
	R 457	NRSA63J-822X	MG RESISTOR				R1170	NRSA63J-393X	MG RESISTOR		
	R 458	NRSA63J-103X	MG RESISTOR				R1171	NRSA63J-332X	MG RESISTOR		
	R 459	NRSA63J-102X	MG RESISTOR				R1172	NRSA63J-332X	MG RESISTOR		
	R 461	NRSA63J-432X	MG RESISTOR				R1173	NRSA63J-393X	MG RESISTOR		
	R 462	NRSA63J-822X	MG RESISTOR				R1174	NRSA63J-393X	MG RESISTOR		
	R 463	NRSA63J-0R0X	MG RESISTOR				R1175	NRSA63J-332X	MG RESISTOR		
	R 464	NRSA63J-103X	MG RESISTOR				R1176	NRSA63J-393X	MG RESISTOR		
	R 465	NRSA63J-103X	MG RESISTOR				R1181	NRSA63J-124X	MG RESISTOR		
	R 467	NRSA63J-103X	MG RESISTOR				R1182	NRSA63J-124X	MG RESISTOR		
	R 468	NRSA63J-103X	MG RESISTOR				R1197	NRSA63J-474X	MG RESISTOR		
	R 471	NRSA63J-102X	MG RESISTOR				R1251	NRSA63J-223X	MG RESISTOR		
	R 472	NRSA63J-102X	MG RESISTOR				R1252	NRSA63J-223X	MG RESISTOR		
	R 473	NRSA63J-102X	MG RESISTOR				R2501	NRSA63J-104X	MG RESISTOR		
	R 474	NRSA63J-102X	MG RESISTOR				R2502	NRSA63J-104X	MG RESISTOR		
	R 475	NRSA63J-102X	MG RESISTOR				R2503	NRSA63J-563X	MG RESISTOR		
	R 476	NRSA63J-102X	MG RESISTOR				R2504	NRSA63J-563X	MG RESISTOR		
	R 481	NRSA63J-222X	MG RESISTOR				R2505	NRSA63J-113X	MG RESISTOR		
	R 482	NRSA63J-103X	MG RESISTOR				R2506	NRSA63J-113X	MG RESISTOR		
	R 483	NRSA63J-105X	MG RESISTOR				R2507	NRSA63J-103X	MG RESISTOR		
	R1101	NRSA63J-471X	MG RESISTOR				R2508	NRSA63J-103X	MG RESISTOR		
	R1102	NRSA63J-471X	MG RESISTOR				R2509	NRSA63J-103X	MG RESISTOR		
	R1103	NRSA63J-104X	MG RESISTOR				R2510	NRSA63J-103X	MG RESISTOR		
	R1104	NRSA63J-104X	MG RESISTOR				R2511	NRSA63J-102X	MG RESISTOR		
	R1121	NRSA63J-103X	MG RESISTOR				R2512	NRSA63J-102X	MG RESISTOR		
	R1122	NRSA63J-103X	MG RESISTOR				R2513	NRSA63J-102X	MG RESISTOR		
	R1123	NRSA63J-103X	MG RESISTOR				R2514	NRSA63J-102X	MG RESISTOR		
	R1131	NRSA63J-104X	MG RESISTOR				R2515	NRSA63J-102X	MG RESISTOR		
	R1132	NRSA63J-104X	MG RESISTOR				R2516	NRSA63J-102X	MG RESISTOR		
	R1133	NRSA63J-102X	MG RESISTOR				R2517	NRSA63J-102X	MG RESISTOR		
	R1134	NRSA63J-102X	MG RESISTOR				R2518	NRSA63J-102X	MG RESISTOR		
	R1135	NRSA63J-332X	MG RESISTOR				R2519	NRSA63J-102X	MG RESISTOR		
	R1136	NRSA63J-332X	MG RESISTOR				R2520	NRSA63J-102X	MG RESISTOR		
	R1137	NRSA63J-104X	MG RESISTOR				R2521	NRSA63J-102X	MG RESISTOR		
	R1138	NRSA63J-104X	MG RESISTOR				R2522	NRSA63J-102X	MG RESISTOR		
	R1139	NRSA63J-104X	MG RESISTOR				R2523	NRSA63J-102X	MG RESISTOR		
	R1140	NRSA63J-104X	MG RESISTOR				R2524	NRSA63J-102X	MG RESISTOR		
	R1141	NRSA63J-102X	MG RESISTOR				R2525	NRSA63J-102X	MG RESISTOR		
	R1142	NRSA63J-102X	MG RESISTOR				R2526	NRSA63J-102X	MG RESISTOR		
	R1143	NRSA63J-332X	MG RESISTOR				R2527	NRSA63J-104X	MG RESISTOR		
	R1144	NRSA63J-332X	MG RESISTOR				R2528	NRSA63J-104X	MG RESISTOR		
	R1145	NRSA63J-104X	MG RESISTOR				R2529	NRSA63J-103X	MG RESISTOR		
	R1146	NRSA63J-104X	MG RESISTOR				R2530	NRSA63J-103X	MG RESISTOR		
	R1147	NRSA63J-104X	MG RESISTOR				R2531	NRSA63J-104X	MG RESISTOR		
	R1148	NRSA63J-104X	MG RESISTOR				R2532	NRSA63J-104X	MG RESISTOR		
	R1149	NRSA63J-471X	MG RESISTOR				R2533	NRSA63J-223X	MG RESISTOR		
	R1150	NRSA63J-102X	MG RESISTOR				R2534	NRSA63J-223X	MG RESISTOR		
	R1151	NRSA63J-472X	MG RESISTOR				R2535	NRSA63J-563X	MG RESISTOR		
	R1152	NRSA63J-332X	MG RESISTOR				R2536	NRSA63J-563X	MG RESISTOR		
	R1153	NRSA63J-471X	MG RESISTOR				R2537	NRSA63J-104X	MG RESISTOR		
	R1154	NRSA63J-472X	MG RESISTOR				R2538	NRSA63J-104X	MG RESISTOR		
	R1155	NRSA63J-104X	MG RESISTOR				R2561	NRSA63J-104X	MG RESISTOR		
	R1156	NRSA63J-104X	MG RESISTOR				R2562	NRSA63J-104X	MG RESISTOR		
	R1157	NRSA63J-332X	MG RESISTOR				R2563	NRSA63J-103X	MG RESISTOR		
	R1158	NRSA63J-104X	MG RESISTOR				R2564	NRSA63J-103X	MG RESISTOR		
	R1161	NRSA63J-104X	MG RESISTOR				R2565	NRSA63J-392X	MG RESISTOR		
	R1162	NRSA63J-104X	MG RESISTOR				R2566	NRSA63J-392X	MG RESISTOR		
	R1163	NRSA63J-104X	MG RESISTOR				R2567	NRSA63J-103X	MG RESISTOR		
	R1164	NRSA63J-104X	MG RESISTOR				R2568	NRSA63J-103X	MG RESISTOR		
	R1165	NRSA63J-104X	MG RESISTOR				R2571	NRSA63J-102X	MG RESISTOR		
	R1166	NRSA63J-104X	MG RESISTOR				R2572	NRSA63J-102X	MG RESISTOR		
	R1167	NRSA63J-332X	MG RESISTOR				R2573	NRSA63J-102X	MG RESISTOR		

■ Electrical parts list (DSP&audio board)

Block No. 03

△	Item	Parts number	Parts name	Remarks	Area
	R2574	NRSA63J-102X	MG RESISTOR		
	R2575	NRSA63J-102X	MG RESISTOR		
	R2576	NRSA63J-102X	MG RESISTOR		
	R2577	NRSA63J-104X	MG RESISTOR		
	R2578	NRSA63J-104X	MG RESISTOR		
	R2579	NRSA63J-104X	MG RESISTOR		
	R2580	NRSA63J-104X	MG RESISTOR		
	R2581	NRSA63J-104X	MG RESISTOR		
	R2582	NRSA63J-104X	MG RESISTOR		
	R2583	NRSA63J-103X	MG RESISTOR		
	R2584	NRSA63J-124X	MG RESISTOR		
	R2585	NRSA63J-392X	MG RESISTOR		
	R2586	NRSA63J-123X	MG RESISTOR		
	R2587	NRSA63J-103X	MG RESISTOR		
	R2588	NRSA63J-103X	MG RESISTOR		
	R2590	NRSA63J-333X	MG RESISTOR		
	R2591	NRSA63J-102X	MG RESISTOR		
	R2592	NRSA63J-333X	MG RESISTOR		
	R2593	NRSA63J-102X	MG RESISTOR		
	R2594	NRSA63J-333X	MG RESISTOR		
	R2595	NRSA63J-102X	MG RESISTOR		
	R2596	NRSA63J-102X	MG RESISTOR		
	R2597	NRSA63J-104X	MG RESISTOR		
	R2598	NRSA63J-104X	MG RESISTOR		
	R2599	NRSA63J-104X	MG RESISTOR		
	R2600	NRSA63J-104X	MG RESISTOR		
	X 401	NAX0385-001X	CRYSTAL	22.5792MHZ	
	X 402	NAX0275-001X	1COSCILLATOR	6.14MHZ	

■ Electrical parts list (DVD servo board)

Block No. 04

△	Item	Parts number	Parts name	Remarks	Area	△	Item	Parts number	Parts name	Remarks	Area
	C 1	NCB31CK-104X	C CAPACITOR				C 227	NCB31HK-102X	C CAPACITOR		
	C 2	NEA70JM-226X	E CAPACITOR				C 228	NCB31HK-102X	C CAPACITOR		
	C 3	NEA70JM-226X	E CAPACITOR				C 237	NCB31CK-104X	C CAPACITOR		
	C 4	NCB31CK-104X	C CAPACITOR				C 238	NCB31CK-104X	C CAPACITOR		
	C 5	NEX40JM-156X	E.CAPACITOR				C 239	NCB31CK-183X	C CAPACITOR		
	C 6	NCB31CK-104X	C CAPACITOR				C 240	NCS31HJ-470X	C CAPACITOR		
	C 11	NEA70JM-107X	E.CAPACITOR				C 241	NCB31CK-103X	C CAPACITOR		
	C 12	NCB31CK-104X	C CAPACITOR				C 242	NCB11CK-105X	C CAPACITOR		
	C 15	NCB31CK-104X	C CAPACITOR				C 244	NCB31CK-104X	C CAPACITOR		
	C 16	NBE20JM-106X	TS E CAP SVB20J				C 245	NCB31CK-103X	C CAPACITOR		
	C 17	NCB31CK-104X	C CAPACITOR				C 246	NCB31CK-104X	C CAPACITOR		
	C 101	NCB31HK-561X	C CAPACITOR				C 247	NCB31CK-104X	C CAPACITOR		
	C 102	NCB31CK-104X	C CAPACITOR				C 248	NCB21CK-154X	C.CAPACITOR		
	C 103	NCB31CK-104X	C CAPACITOR				C 249	NCB31CK-104X	C CAPACITOR		
	C 104	NCB31CK-104X	C CAPACITOR				C 250	NCB31CK-104X	C CAPACITOR		
	C 105	NCB31CK-104X	C CAPACITOR				C 251	NCB31CK-104X	C CAPACITOR		
	C 109	NEA70JM-476X	E.CAPACITOR				C 252	NCB31CK-104X	C CAPACITOR		
	C 112	NEA70JM-476X	E.CAPACITOR				C 253	NCB31CK-104X	C CAPACITOR		
	C 118	NCB21CK-154X	C.CAPACITOR				C 254	NEA70GM-336X	E CAPACITOR		
	C 119	NCS31HJ-221X	C CAPACITOR				C 255	NCB31CK-104X	C CAPACITOR		
	C 120	NCS31HJ-820X	C CAPACITOR				C 256	NEA70GM-107X	E CAPACITOR		
	C 121	NCS31HJ-220X	C CAPACITOR				C 257	NCB11CK-105X	C CAPACITOR		
	C 122	NCB31HK-271X	C CAPACITOR				C 258	NEA70GM-107X	E CAPACITOR		
	C 123	NCB31CK-104X	C CAPACITOR				C 259	NCB11CK-105X	C CAPACITOR		
	C 124	NCB31CK-104X	C CAPACITOR				C 260	NCB31HK-561X	C CAPACITOR		
	C 125	NCB31CK-104X	C CAPACITOR				C 261	NCB31CK-104X	C CAPACITOR		
	C 126	NEX40JM-566X	E CAPACITOR				C 262	NCB31CK-104X	C CAPACITOR		
	C 127	NCB31HK-102X	C CAPACITOR				C 263	NCB31CK-104X	C CAPACITOR		
	C 128	NCB31CK-104X	C CAPACITOR				C 264	NCB21CK-474X	C CAPACITOR		
	C 130	NCB31CK-104X	C CAPACITOR				C 271	NCB31EK-332X	C CAPACITOR		
	C 131	NCS31HJ-120X	C CAPACITOR				C 272	NCB31HK-331X	C CAPACITOR		
	C 132	NCB31CK-104X	C CAPACITOR				C 276	NCB31CK-104X	C CAPACITOR		
	C 133	NCB31HK-561X	C CAPACITOR				C 277	NCB31CK-104X	C CAPACITOR		
	C 134	NCB31HK-561X	C CAPACITOR				C 278	NCB31HK-102X	C CAPACITOR		
	C 135	NCB31CK-273X	C CAPACITOR				C 279	NCB31HK-272X	C CAPACITOR		
	C 136	NCB31CK-473X	C CAPACITOR				C 281	NCB31CK-103X	C CAPACITOR		
	C 138	NCB31CK-104X	C CAPACITOR				C 283	NCB31CK-223X	C CAPACITOR		
	C 139	NCB31CK-104X	C CAPACITOR				C 284	NCB31CK-473X	C CAPACITOR		
	C 140	NEA70JM-226X	E CAPACITOR				C 288	NCB31CK-223X	C CAPACITOR		
	C 141	NCB31CK-104X	C CAPACITOR				C 289	NCB31CK-104X	C CAPACITOR		
	C 143	NCB31CK-104X	C CAPACITOR				C 291	NCB31CK-104X	C CAPACITOR		
	C 144	NCB31CK-104X	C CAPACITOR				C 292	NEA70JM-226X	E CAPACITOR		
	C 145	NCB31CK-103X	C CAPACITOR				C 293	NEA71CM-226X	E.CAPAP. C.M		
	C 151	NEX40JM-156X	E.CAPACITOR				C 301	NCB31CK-104X	C CAPACITOR		
	C 152	NEX40JM-156X	E.CAPACITOR				C 302	NCB31CK-104X	C CAPACITOR		
	C 153	NCB31CK-104X	C CAPACITOR				C 303	NCB31CK-104X	C CAPACITOR		
	C 159	NCB31CK-104X	C CAPACITOR				C 304	NCB31CK-104X	C CAPACITOR		
	C 160	NCB31CK-104X	C CAPACITOR				C 305	NCB31CK-104X	C CAPACITOR		
	C 161	NEA70GM-336X	E CAPACITOR				C 306	NCB31CK-104X	C CAPACITOR		
	C 199	NCB31CK-103X	C CAPACITOR				C 307	NCB31CK-104X	C CAPACITOR		
	C 202	NCB31HK-561X	C CAPACITOR				C 309	NCB31CK-104X	C CAPACITOR		
	C 203	NCB31HK-561X	C CAPACITOR				C 310	NCB31CK-104X	C CAPACITOR		
	C 204	NCB31HK-331X	C CAPACITOR				C 311	NCB31CK-104X	C CAPACITOR		
	C 205	NCS31HJ-121X	C CAPACITOR				C 312	NCS31HJ-180X	C CAPACITOR		
	C 206	NCS31HJ-271X	C CAPACITOR				C 313	NCS31HJ-180X	C CAPACITOR		
	C 207	NCB31HK-471X	C CAPACITOR				C 314	NCB31CK-104X	C CAPACITOR		
	C 208	NCB31CK-104X	C CAPACITOR				C 315	NCB31CK-104X	C CAPACITOR		
	C 209	NCB31HK-102X	C CAPACITOR				C 316	NEA70GM-107X	E CAPACITOR		
	C 210	NCB31HK-102X	C CAPACITOR				C 317	NCB11CK-105X	C CAPACITOR		
	C 222	NCB31HK-562X	C CAPACITOR				C 318	NCB31CK-104X	C CAPACITOR		
	C 223	NCB31HK-102X	C CAPACITOR				C 319	NCB31CK-104X	C CAPACITOR		
	C 224	NCB31CK-104X	C CAPACITOR				C 320	NCB31CK-104X	C CAPACITOR		
	C 225	NBE91CM-105X	E CAPACITOR				C 321	NCB31CK-104X	C CAPACITOR		

■ Electrical parts list (DVD&servo board)

Block No. 04

△	Item	Parts number	Parts name	Remarks	Area	△	Item	Parts number	Parts name	Remarks	Area
	C 324	NCB31CK-104X	C CAPACITOR				C 557	NCB31CK-104X	C CAPACITOR		
	C 326	NCB31CK-104X	C CAPACITOR				C 561	NCB31CK-104X	C CAPACITOR		
	C 327	NEA70JM-107X	E CAPACITOR				C 562	NEA70JM-226X	E CAPACITOR		
	C 341	NCB31CK-104X	C CAPACITOR				C 563	NCB31CK-104X	C CAPACITOR		
	C 342	NCB31CK-104X	C CAPACITOR				C 564	NCB31CK-104X	C CAPACITOR		
	C 343	NCB31CK-104X	C CAPACITOR				C 565	NCB31CK-104X	C CAPACITOR		
	C 344	NCB31CK-104X	C CAPACITOR				C 566	NCB31CK-104X	C CAPACITOR		
	C 345	NEA70JM-107X	E.CAPACITOR				C 567	NEA70JM-226X	E CAPACITOR		
	C 346	NCB11CK-105X	C CAPACITOR				C 568	NCB31CK-104X	C CAPACITOR		
	C 401	NCB31CK-104X	C CAPACITOR				C 569	NEA70JM-226X	E CAPACITOR		
	C 402	NCB31CK-104X	C CAPACITOR				C 570	NCB31CK-104X	C CAPACITOR		
	C 405	NCB31CK-104X	C CAPACITOR				C 579	NCB31CK-103X	C CAPACITOR		
	C 406	NCB31CK-104X	C CAPACITOR				CN101	QGF0501F3-40X	FFC/FPC CONNE	PU	
	C 407	NCB31CK-104X	C CAPACITOR				CN501	QGB2027L1-10X	W TO B CONNE	POWER	
	C 408	NEA70JM-226X	E CAPACITOR				CN502	QGB2027L1-22X	CONNECTOR	SYSTEM	
	C 409	NCB31CK-104X	C CAPACITOR				CN503	QGB2027L1-10X	W TO B CONNE	VIDEO	
	C 410	NCB31CK-103X	C CAPACITOR				D 199	MA3051/M/-X	ZENER DIODE		
	C 411	NCB31CK-104X	C CAPACITOR				D 501	1SR154-400-X	DIODE		
	C 412	NCB31CK-104X	C CAPACITOR				D 551	1SS355-X	DIODE		
	C 501	NCB31CK-104X	C CAPACITOR				D 552	1SS355-X	DIODE		
	C 502	NCB31CK-104X	C CAPACITOR				IC 1	RN5RZ33BA-X	IC		
	C 503	NCB31CK-104X	C CAPACITOR				IC101	AN8702FH	IC		
	C 504	NCB31CK-104X	C CAPACITOR				IC102	RN5RZ33BA-X	IC		
	C 505	NCB31CK-104X	C CAPACITOR				IC201	MN67706ZY	IC		
	C 506	NCB31CK-104X	C CAPACITOR				IC202	TC7WT125FU-X	IC(DIGITAL)		
	C 507	NCB31CK-104X	C CAPACITOR				IC271	M56788FP-W	IC		
	C 508	NCB31CK-104X	C CAPACITOR				IC301	MN103S13BDA	IC		
	C 509	NCB31CK-104X	C CAPACITOR				IC311	TC7SH08FU-X	IC		
	C 510	NCB31CK-104X	C CAPACITOR				IC312	TC7SH32FU-X	IC		
	C 511	NCB31CK-104X	C CAPACITOR				IC321	TC7WH74FU-X	IC		
	C 512	NCB31CK-104X	C CAPACITOR				IC322	TC74VHC00FT-X	IC		
	C 513	NCB31CK-104X	C CAPACITOR				IC401	MN102L25GHW1	IC		
	C 514	NCB31CK-104X	C CAPACITOR				IC402	K3N5C1000D-J007	IC C.M		
	C 515	NCB31CK-104X	C CAPACITOR				IC403	AK93C65AF-X	IC		
	C 516	NCB31CK-104X	C CAPACITOR				IC501	ZIVA3-PE0	IC		
	C 517	NCB31CK-104X	C CAPACITOR				IC502	NAX0393-001X	CXO C.M	27MHZ	
	C 518	NCB31CK-104X	C CAPACITOR				IC503	TC74VHC00FT-X	IC		
	C 519	NCB31CK-104X	C CAPACITOR				IC504	W981616AH-7	IC		
	C 520	NCB31CK-104X	C CAPACITOR				IC505	W981616AH-7	IC		
	C 521	NCB31CK-104X	C CAPACITOR				IC554	MC44724AVFU	IC		
	C 522	NCB31CK-104X	C CAPACITOR				K 102	NQR0007-002X	FERRITE BEADS		
	C 523	NCB31CK-104X	C CAPACITOR				K 103	NQR0007-002X	FERRITE BEADS		
	C 524	NCB31CK-104X	C CAPACITOR				K 201	NQR0007-002X	FERRITE BEADS		
	C 525	NCB31CK-104X	C CAPACITOR				K 202	NQR0007-002X	FERRITE BEADS		
	C 526	NCB31CK-104X	C CAPACITOR				K 203	NQR0007-002X	FERRITE BEADS		
	C 527	NCB31CK-104X	C CAPACITOR				K 301	NQR0007-002X	FERRITE BEADS		
	C 528	NCB31CK-104X	C CAPACITOR				K 302	NQR0007-002X	FERRITE BEADS		
	C 529	NCB31CK-104X	C CAPACITOR				K 303	NQR0007-002X	FERRITE BEADS		
	C 530	NEA70JM-107X	E.CAPACITOR				K 401	NQR0007-002X	FERRITE BEADS		
	C 531	NCB31CK-104X	C CAPACITOR				K 402	NQR0007-002X	FERRITE BEADS		
	C 532	NCB31CK-104X	C CAPACITOR				K 501	NQR0007-002X	FERRITE BEADS		
	C 533	NCB31CK-104X	C CAPACITOR				K 502	NQR0007-002X	FERRITE BEADS		
	C 534	NEA70JM-107X	E.CAPACITOR				K 503	NQR0007-002X	FERRITE BEADS		
	C 535	NCB31CK-104X	C CAPACITOR				K 504	NQR0201-001X	FERRITE BEADS		
	C 536	NCB31CK-103X	C CAPACITOR				K 505	NQR0269-001X	FERRITE BEADS		
	C 537	NEA70JM-226X	E CAPACITOR				K 506	NQR0007-002X	FERRITE BEADS		
	C 538	NCB31CK-104X	C CAPACITOR				K 507	NQR0007-002X	FERRITE BEADS		
	C 539	NCB31CK-104X	C CAPACITOR				K 550	NQR0007-002X	FERRITE BEADS		
	C 540	NEA70JM-226X	E CAPACITOR				K 551	NQR0007-002X	FERRITE BEADS		
	C 541	NCB31CK-104X	C CAPACITOR				K 553	NQR0007-002X	FERRITE BEADS		
	C 542	NEA70JM-226X	E CAPACITOR				K 554	NQR0007-002X	FERRITE BEADS		
	C 543	NCB31CK-104X	C CAPACITOR				K 555	NQR0007-002X	FERRITE BEADS		
	C 556	NEA70JM-107X	E.CAPACITOR				K 556	NQR0007-002X	FERRITE BEADS		

■ Electrical parts list (DVD&servo board)

Block No. 04

△	Item	Parts number	Parts name	Remarks	Area
	K 557	NQR0007-002X	FERRITE BEADS		
	K 558	NQR0007-002X	FERRITE BEADS		
	K 561	NQR0007-002X	FERRITE BEADS		
	K 562	NQR0007-002X	FERRITE BEADS		
	K 563	NQR0007-002X	FERRITE BEADS		
	K 564	NQR0007-002X	FERRITE BEADS		
	K 565	NQR0007-002X	FERRITE BEADS		
	K 566	NQR0007-002X	FERRITE BEADS		
	K 567	NQR0007-002X	FERRITE BEADS		
	K 568	NQR0007-002X	FERRITE BEADS		
	K 569	NQR0007-002X	FERRITE BEADS		
	K 570	NQR0007-002X	FERRITE BEADS		
	K 571	NQR0007-002X	FERRITE BEADS		
	K 572	NQR0007-002X	FERRITE BEADS		
	K 574	NQR0007-002X	FERRITE BEADS		
	K 575	NQR0007-002X	FERRITE BEADS		
	K 576	NQR0007-002X	FERRITE BEADS		
	K 577	NQR0007-002X	FERRITE BEADS		
	K 578	NQR0007-002X	FERRITE BEADS		
	K 579	NQR0007-002X	FERRITE BEADS		
	L 1	NQL044K-100X	INDUCTOR		
	Q 1	2SD2150/RS-W	POW TRANSISTOR		
	Q 101	2SB1424/QR/-X	TRANSISTOR		
	Q 102	2SB1424/QR/-X	TRANSISTOR		
	Q 275	DTC144EE-X	TRANSISTOR		
	R 1	NRSA63J-100X	MG RESISTOR		
	R 103	NRS125J-270X	MG RESISTOR		
	R 104	NRS125J-270X	MG RESISTOR		
	R 107	NRSA63J-0R0X	MG RESISTOR		
	R 108	NRSA63J-183X	MG RESISTOR		
	R 109	NRSA63J-0R0X	MG RESISTOR		
	R 110	NRSA63J-273X	MG RESISTOR		
	R 111	NRSA63J-0R0X	MG RESISTOR		
	R 112	NRSA63J-273X	MG RESISTOR		
	R 113	NRSA63J-682X	MG RESISTOR		
	R 114	NRSA63J-102X	MG RESISTOR		
	R 115	NRVA63D-243X	MG RESISTOR		
	R 116	NRSA63J-393X	MG RESISTOR		
	R 117	NRSA63J-123X	MG RESISTOR		
	R 118	NRSA63J-223X	MG RESISTOR		
	R 121	NRSA63J-0R0X	MG RESISTOR		
	R 122	NRSA63J-0R0X	MG RESISTOR		
	R 123	NRSA63J-0R0X	MG RESISTOR		
	R 124	NRSA63J-0R0X	MG RESISTOR		
	R 125	NRSA63J-0R0X	MG RESISTOR		
	R 126	NRSA63J-0R0X	MG RESISTOR		
	R 127	NRSA63J-222X	MG RESISTOR		
	R 128	NRSA63J-105X	MG RESISTOR		
	R 129	NRSA63J-105X	MG RESISTOR		
	R 131	NRSA63J-822X	MG RESISTOR		
	R 132	NRSA63J-103X	MG RESISTOR		
	R 144	NRSA63J-333X	MG RESISTOR		
	R 145	NRSA63J-103X	MG RESISTOR		
	R 152	NRS125J-1R0X	MG RESISTOR		
	R 153	NRS125J-4R7X	MG RESISTOR		
	R 155	NRSA63J-0R0X	MG RESISTOR		
	R 156	NRSA63J-333X	MG RESISTOR		
	R 160	NRSA63J-0R0X	MG RESISTOR		
	R 161	NRSA63J-0R0X	MG RESISTOR		
	R 162	NRSA63J-0R0X	MG RESISTOR		
	R 163	NRSA63J-0R0X	MG RESISTOR		
	R 166	NRSA63J-182X	MG RESISTOR		
	R 202	NRSA63J-473X	MG RESISTOR		

△	Item	Parts number	Parts name	Remarks	Area
	R 203	NRSA63J-473X	MG RESISTOR		
	R 204	NRSA63J-473X	MG RESISTOR		
	R 205	NRSA63J-473X	MG RESISTOR		
	R 208	NRSA63J-473X	MG RESISTOR		
	R 209	NRSA63J-123X	MG RESISTOR		
	R 210	NRSA63J-473X	MG RESISTOR		
	R 211	NRSA63J-273X	MG RESISTOR		
	R 212	NRSA63J-273X	MG RESISTOR		
	R 213	NRSA63J-562X	MG RESISTOR		
	R 214	NRSA63J-123X	MG RESISTOR		
	R 215	NRSA63J-105X	MG RESISTOR		
	R 218	NRSA63J-153X	MG RESISTOR		
	R 219	NRSA63J-473X	MG RESISTOR		
	R 220	NRSA63J-473X	MG RESISTOR		
	R 223	NRSA63J-473X	MG RESISTOR		
	R 224	NRSA63J-0R0X	MG RESISTOR		
	R 225	NRSA63J-682X	MG RESISTOR		
	R 227	NRSA63J-102X	MG RESISTOR		
	R 228	NRSA63J-183X	MG RESISTOR		
	R 229	NRSA63J-273X	MG RESISTOR		
	R 230	NRSA63J-273X	MG RESISTOR		
	R 232	NRSA63J-472X	MG RESISTOR		
	R 233	NRSA63J-472X	MG RESISTOR		
	R 234	NRSA63J-472X	MG RESISTOR		
	R 235	NRSA63J-0R0X	MG RESISTOR		
	R 237	NRSA63J-221X	MG RESISTOR		
	R 238	NRSA63J-221X	MG RESISTOR		
	R 239	NRSA63J-221X	MG RESISTOR		
	R 240	NRSA63J-221X	MG RESISTOR		
	R 241	NRSA63J-221X	MG RESISTOR		
	R 242	NRSA63J-102X	MG RESISTOR		
	R 243	NRSA63J-102X	MG RESISTOR		
	R 244	NRSA63J-102X	MG RESISTOR		
	R 245	NRSA63J-102X	MG RESISTOR		
	R 246	NRSA63J-102X	MG RESISTOR		
	R 248	NRSA63J-473X	MG RESISTOR		
	R 249	NRSA63J-473X	MG RESISTOR		
	R 250	NRSA63J-473X	MG RESISTOR		
	R 253	NRS125J-4R7X	MG RESISTOR		
	R 255	NRSA63J-123X	MG RESISTOR		
	R 256	NRSA63J-0R0X	MG RESISTOR		
	R 257	NRSA63J-0R0X	MG RESISTOR		
	R 271	NRSA63J-563X	MG RESISTOR		
	R 272	NRSA63J-103X	MG RESISTOR		
	R 273	NRS125J-1R0X	MG RESISTOR		
	R 274	NRSA63J-0R0X	MG RESISTOR		
	R 275	NRSA63J-103X	MG RESISTOR		
	R 276	NRSA63J-103X	MG RESISTOR		
	R 277	NRSA63J-103X	MG RESISTOR		
	R 278	NRSA63J-103X	MG RESISTOR		
	R 279	NRSA63J-103X	MG RESISTOR		
	R 280	NRSA63J-103X	MG RESISTOR		
	R 282	NRSA63J-183X	MG RESISTOR		
	R 283	NRSA63J-103X	MG RESISTOR		
	R 284	NRSA63J-472X	MG RESISTOR		
	R 285	NRSA63J-103X	MG RESISTOR		
	R 286	NRSA63J-103X	MG RESISTOR		
	R 287	NRSA63J-103X	MG RESISTOR		
	R 288	NRSA63J-103X	MG RESISTOR		
	R 289	NRSA63J-103X	MG RESISTOR		
	R 290	NRSA63J-103X	MG RESISTOR		
	R 292	NRSA63J-223X	MG RESISTOR		
	R 295	NRSA63J-103X	MG RESISTOR		

■ Electrical parts list (DVD servo board)

Block No. 04

△	Item	Parts number	Parts name	Remarks	Area
	R 296	NRSA63J-103X	MG RESISTOR		
	R 297	NRS125J-1R0X	MG RESISTOR		
	R 301	NRSA63J-473X	MG RESISTOR		
	R 302	NRSA63J-473X	MG RESISTOR		
	R 303	NRSA63J-473X	MG RESISTOR		
	R 304	NRSA63J-473X	MG RESISTOR		
	R 305	NRSA63J-473X	MG RESISTOR		
	R 306	NRSA63J-473X	MG RESISTOR		
	R 307	NRSA63J-473X	MG RESISTOR		
	R 308	NRSA63J-473X	MG RESISTOR		
	R 309	NRSA63J-103X	MG RESISTOR		
	R 310	NRSA63J-102X	MG RESISTOR		
	R 311	NRSA63J-102X	MG RESISTOR		
	R 312	NRSA63J-102X	MG RESISTOR		
	R 316	NRSA63J-105X	MG RESISTOR		
	R 317	NRSA63J-0R0X	MG RESISTOR		
	R 318	NRSA63J-0R0X	MG RESISTOR		
	R 322	NRSA63J-473X	MG RESISTOR		
	R 324	NRSA63J-473X	MG RESISTOR		
	R 328	NRSA63J-473X	MG RESISTOR		
	R 342	NRSA63J-0R0X	MG RESISTOR		
	R 343	NRSA63J-102X	MG RESISTOR		
	R 345	NRSA63J-562X	MG RESISTOR		
	R 346	NRSA63J-472X	MG RESISTOR		
	R 347	NRSA63J-102X	MG RESISTOR		
	R 348	NRSA63J-102X	MG RESISTOR		
	R 349	NRSA63J-102X	MG RESISTOR		
	R 350	NRSA63J-102X	MG RESISTOR		
	R 364	NRSA63J-0R0X	MG RESISTOR		
	R 403	NRSA63J-472X	MG RESISTOR		
	R 405	NRSA63J-472X	MG RESISTOR		
	R 408	NRSA63J-472X	MG RESISTOR		
	R 410	NRSA63J-0R0X	MG RESISTOR		
	R 411	NRSA63J-472X	MG RESISTOR		
	R 412	NRSA63J-103X	MG RESISTOR		
	R 413	NRSA63J-472X	MG RESISTOR		
	R 414	NRSA63J-472X	MG RESISTOR		
	R 415	NRSA63J-472X	MG RESISTOR		
	R 416	NRSA63J-472X	MG RESISTOR		
	R 417	NRSA63J-472X	MG RESISTOR		
	R 418	NRSA63J-472X	MG RESISTOR		
	R 422	NRSA63J-0R0X	MG RESISTOR		
	R 423	NRSA63J-0R0X	MG RESISTOR		
	R 424	NRSA63J-0R0X	MG RESISTOR		
	R 431	NRSA63J-472X	MG RESISTOR		
	R 432	NRSA63J-472X	MG RESISTOR		
	R 501	NRSA63J-102X	MG RESISTOR		
	R 502	NRSA63J-222X	MG RESISTOR		
	R 504	NRSA63J-330X	MG RESISTOR		
	R 505	NRSA63J-330X	MG RESISTOR		
	R 506	NRSA63J-330X	MG RESISTOR		
	R 507	NRSA63J-330X	MG RESISTOR		
	R 508	NRSA63J-330X	MG RESISTOR		
	R 509	NRSA63J-330X	MG RESISTOR		
	R 510	NRSA63J-330X	MG RESISTOR		
	R 511	NRSA63J-330X	MG RESISTOR		
	R 512	NRSA63J-330X	MG RESISTOR		
	R 513	NRSA63J-330X	MG RESISTOR		
	R 514	NRSA63J-330X	MG RESISTOR		
	R 515	NRSA63J-330X	MG RESISTOR		
	R 516	NRSA63J-330X	MG RESISTOR		
	R 517	NRSA63J-330X	MG RESISTOR		
	R 518	NRSA63J-330X	MG RESISTOR		

△	Item	Parts number	Parts name	Remarks	Area
	R 519	NRSA63J-330X	MG RESISTOR		
	R 520	NRSA63J-330X	MG RESISTOR		
	R 521	NRSA63J-330X	MG RESISTOR		
	R 522	NRSA63J-330X	MG RESISTOR		
	R 523	NRSA63J-181X	MG RESISTOR		
	R 524	NRSA63J-181X	MG RESISTOR		
	R 525	NRSA63J-181X	MG RESISTOR		
	R 526	NRSA63J-181X	MG RESISTOR		
	R 527	NRSA63J-181X	MG RESISTOR		
	R 528	NRSA63J-181X	MG RESISTOR		
	R 529	NRSA63J-181X	MG RESISTOR		
	R 530	NRSA63J-181X	MG RESISTOR		
	R 531	NRSA63J-330X	MG RESISTOR		
	R 532	NRSA63J-0R0X	MG RESISTOR		
	R 533	NRSA63J-330X	MG RESISTOR		
	R 534	NRSA63J-330X	MG RESISTOR		
	R 535	NRSA63J-330X	MG RESISTOR		
	R 536	NRSA63J-330X	MG RESISTOR		
	R 537	NRSA63J-330X	MG RESISTOR		
	R 538	NRSA63J-330X	MG RESISTOR		
	R 539	NRSA63J-330X	MG RESISTOR		
	R 540	NRSA63J-330X	MG RESISTOR		
	R 541	NRSA63J-0R0X	MG RESISTOR		
	R 542	NRSA63J-0R0X	MG RESISTOR		
	R 543	NRSA63J-0R0X	MG RESISTOR		
	R 544	NRSA63J-0R0X	MG RESISTOR		
	R 545	NRSA63J-472X	MG RESISTOR		
	R 547	NRSA63J-222X	MG RESISTOR		
	R 548	NRSA63J-332X	MG RESISTOR		
	R 550	NRSA63J-0R0X	MG RESISTOR		
	R 564	NRVA63D-152X	MG RESISTOR		
	R 565	NRVA63D-332X	MF RESISTOR		
	R 571	NRSA63J-100X	MG RESISTOR		
	R 572	NRSA63J-181X	MG RESISTOR		
	R 573	NRSA63J-181X	MG RESISTOR		
	R 574	NRSA63J-181X	MG RESISTOR		
	R 575	NRSA63J-181X	MG RESISTOR		
	R 576	NRSA63J-181X	MG RESISTOR		
	R 577	NRSA63J-181X	MG RESISTOR		
	R 578	NRSA63J-181X	MG RESISTOR		
	R 579	NRSA63J-181X	MG RESISTOR		
	R 580	NRSA63J-181X	MG RESISTOR		
	R 581	NRSA63J-101X	MG RESISTOR		
	R 582	NRSA63J-181X	MG RESISTOR		
	R 586	NRVA63D-122X	MG RESISTOR		
	R 587	NRVA63D-122X	MG RESISTOR		
	R 588	NRVA63D-102X	CMF RESISTOR		
	R 589	NRVA63D-102X	CMF RESISTOR		
	X 301	NAX0375-001X	CRYSTAL	16.9344MHZ	
	X 401	NAX0331-001X	C RESONATOR		

■ Electrical parts list (Connection board)

Block No. 05

△	Item	Parts number	Parts name	Remarks	Area
	C 13	NCS31HJ-101X	C.CAPACITOR		
	CN 10	QGF0501F4-40X	FFC/FPC CONNE	FOR MAIN	
	CN 12	QGF1012F1-30X	FPC CONNE	FOR P.U	
	IC 1	GP2S60B-X	IC(PHOTO COUPLE		
	K 10	NQR0265-003X	FERRITE BEADS		
	K 11	NQR0265-003X	FERRITE BEADS		
	K 12	NQR0265-003X	FERRITE BEADS		
	K 13	NQR0265-003X	FERRITE BEADS		
	K 14	NQR0265-003X	FERRITE BEADS		
	K 15	NQR0265-003X	FERRITE BEADS		
	K 16	NQR0265-003X	FERRITE BEADS		
	K 17	NQR0265-003X	FERRITE BEADS		
	K 18	NQR0265-003X	FERRITE BEADS		
	R 10	NRSA63J-391X	MG RESISTOR		
	R 11	NRSA63J-910X	MG RESISTOR		
	R 12	NRSA63J-911X	MG RESISTOR		
	S 10	QSW0620-001	DETECT SWITCH	REST SW	
	S 11	NSW0127-001X	SLIDE SWITCH	SHORT SW	

■ Electrical parts list (SP-THA9 Main board) Block No. 06

△	Item	Parts number	Parts name	Remarks	Area	△	Item	Parts number	Parts name	Remarks	Area
	C 100	QTE1H06-475Z	E CAPACITOR				C 551	QFN31HJ-103Z	M CAPACITOR	.010MF 5% 50V	
	C 101	QETN1EM-476Z	E CAPACITOR	47MF 20% 25V			C 552	QETN1HM-475Z	E CAPACITOR	4.7MF 20% 50V	
	C 102	QTE1H06-475Z	E CAPACITOR				C 553	QFN31HJ-103Z	M CAPACITOR	.010MF 5% 50V	
	C 103	QETN1EM-476Z	E CAPACITOR	47MF 20% 25V			C 554	QFN31HJ-103Z	M CAPACITOR	.010MF 5% 50V	
	C 104	QETN1HM-105Z	E CAPACITOR	1.0MF 20% 50V			C 555	QFN31HJ-103Z	M CAPACITOR	.010MF 5% 50V	
	C 105	QETN1EM-476Z	E CAPACITOR	47MF 20% 25V			C 556	QFN31HJ-103Z	M CAPACITOR	.010MF 5% 50V	
	C 106	QFN31HJ-103Z	M CAPACITOR	.010MF 5% 50V			C 557	QFN31HJ-103Z	M CAPACITOR	.010MF 5% 50V	
	C 107	QFN31HJ-103Z	M CAPACITOR	.010MF 5% 50V			C 558	QETN1HM-226Z	E CAPACITOR	22MF 20% 50V	
	C 108	QETN1HM-226Z	E CAPACITOR	22MF 20% 50V			CN101	QGB2510K2-12	CONNECTOR		
	C 109	QTE1H06-475Z	E CAPACITOR				CN104	QGA3901C1-05	5P CONNECTOR		
	C 110	QFN31HJ-103Z	M CAPACITOR	.010MF 5% 50V			CN201	QGB2510J1-12	CONNECTOR		
	C 111	QETN1HM-226Z	E CAPACITOR	22MF 20% 50V			CN202	QGB2510J1-06	CONNECTOR		
	C 112	QTE1H06-475Z	E CAPACITOR				CN203	QGB2510J1-14	CONNECTOR		
	C 113	QFN31HJ-103Z	M CAPACITOR	.010MF 5% 50V			CN205	QGB2510J1-20	CONNECTOR		
	C 114	QETN1HM-226Z	E CAPACITOR	22MF 20% 50V			CN206	QGB2510J1-14	CONNECTOR		
	C 115	QETN1HM-105Z	E CAPACITOR	1.0MF 20% 50V			CN210	QGB2510J1-10	CONNECTOR		
	C 116	QETN1HM-106Z	E CAPACITOR	10MF 20% 50V			CN211	QGB2510J1-12	CONNECTOR		
	C 118	QFN31HJ-103Z	M CAPACITOR	.010MF 5% 50V			D 500	1SS133-T2	SI DIODE		
	C 119	QFN31HJ-103Z	M CAPACITOR	.010MF 5% 50V			D 501	1SS133-T2	SI DIODE		
	C 120	QCB1HK-101Y	C CAPACITOR	100PF 10% 50V			D 502	MTZJ5.1C-T2	ZENER DIODE		
	C 121	QCB1HK-101Y	C CAPACITOR	100PF 10% 50V			D 503	1SS133-T2	SI DIODE		
	C 122	QCB1HK-101Y	C CAPACITOR	100PF 10% 50V			D 504	1SS133-T2	SI DIODE		
	C 123	QCB1HK-101Y	C CAPACITOR	100PF 10% 50V			D 505	1SS133-T2	SI DIODE		
	C 124	QCB1HK-101Y	C CAPACITOR	100PF 10% 50V			D 506	MTZJ30C-T2	ZENER DIODE		
	C 125	QCB1HK-101Y	C CAPACITOR	100PF 10% 50V			D 508	MTZJ5.1B-T2	ZENER DIODE		
	C 126	QCSB1HJ-100Y	C CAPACITOR	10PF 5% 50V			D 509	MTZJ12C-T2	ZENER DIODE		
	C 128	QETN1HM-475Z	E CAPACITOR	4.7MF 20% 50V			D 510	MTZJ12C-T2	ZENER DIODE		
	C 129	QETN1HM-475Z	E CAPACITOR	4.7MF 20% 50V		△	D 511	1N5402M-20	DIODE		
	C 500	QFVF1HJ-104Z	MF CAPACITOR	.10MF 5% 50V		△	D 512	1N5402M-20	DIODE		
	C 501	QFVF1HJ-104Z	MF CAPACITOR	.10MF 5% 50V		△	D 513	1N5402M-20	DIODE		
	C 502	QFN31HJ-103Z	M CAPACITOR	.010MF 5% 50V		△	D 514	1N5402M-20	DIODE		
	C 503	QFN31HJ-103Z	M CAPACITOR	.010MF 5% 50V		△	D 515	6A20G-E4	DIODE		
	C 504	QFVF1HJ-104Z	MF CAPACITOR	.10MF 5% 50V		△	D 516	6A20G-E4	DIODE		
	C 505	QFVF1HJ-104Z	MF CAPACITOR	.10MF 5% 50V		△	D 517	6A20G-E4	DIODE		
	C 506	QFVF1HJ-104Z	MF CAPACITOR	.10MF 5% 50V		△	D 518	6A20G-E4	DIODE		
	C 507	QFVF1HJ-104Z	MF CAPACITOR	.10MF 5% 50V			D 519	1SS133-T2	SI DIODE		
	C 508	QFN31HJ-103Z	M CAPACITOR	.010MF 5% 50V			D 520	1SS133-T2	SI DIODE		
	C 509	QFN31HJ-103Z	M CAPACITOR	.010MF 5% 50V			D 521	1SS133-T2	SI DIODE		
	C 510	QFVF1HJ-104Z	MF CAPACITOR	.10MF 5% 50V			D 522	1SS133-T2	SI DIODE		
	C 511	QFVF1HJ-104Z	MF CAPACITOR	.10MF 5% 50V			D 523	MTZJ15C-T2	Z DIODE		
	C 512	QFVF1HJ-104Z	MF CAPACITOR	.10MF 5% 50V			D 524	MTZJ6.2B-T2	ZENER DIODE		
	C 513	QFVF1HJ-104Z	MF CAPACITOR	.10MF 5% 50V			D 525	MTZJ6.2B-T2	ZENER DIODE		
	C 514	QFN31HJ-103Z	M CAPACITOR	.010MF 5% 50V			D 526	MTZJ15C-T2	Z DIODE		
	C 515	QFN31HJ-103Z	M CAPACITOR	.010MF 5% 50V			D 527	1SS133-T2	SI DIODE		
	C 516	QETN1EM-107Z	E CAPACITOR	100MF 20% 25V			D 528	1SS133-T2	SI DIODE		
	C 517	QETN1EM-476Z	E CAPACITOR	47MF 20% 25V			D 530	1SS133-T2	SI DIODE		
	C 518	QETN1EM-107Z	E CAPACITOR	100MF 20% 25V			D 531	1SS133-T2	SI DIODE		
	C 519	QETN1EM-476Z	E CAPACITOR	47MF 20% 25V			D 532	MTZJ30C-T2	ZENER DIODE		
	C 520	QEZ2023-478	E CAPACITER	4700MF			D 533	MTZJ6.2B-T2	ZENER DIODE		
	C 521	QEZ2023-478	E CAPACITER	4700MF			D 534	1SS133-T2	SI DIODE		
	C 522	QETM1EM-688	E CAPACITOR	6800MF 20% 25V			D 535	MTZJ15C-T2	Z DIODE		
	C 523	QETM1EM-688	E CAPACITOR	6800MF 20% 25V			D 536	1SS133-T2	SI DIODE		
	C 524	QFLC2AJ-104Z	M CAPACITOR	.10MF 5% 100V			IC100	BA3121	IC		
	C 525	QFLC2AJ-104Z	M CAPACITOR	.10MF 5% 100V			IC101	BA3121	IC		
	C 526	QFLC2AJ-104Z	M CAPACITOR	.10MF 5% 100V			IC102	BA3121	IC		
	C 527	QFLC2AJ-104Z	M CAPACITOR	.10MF 5% 100V			IC103	BA15218N	IC		
	C 528	QFLC2AJ-104Z	M CAPACITOR	.10MF 5% 100V			IC108	BA15218N	IC		
	C 529	QFLC2AJ-104Z	M CAPACITOR	.10MF 5% 100V			IC109	BA15218N	IC		
	C 530	QETN1CM-227Z	E CAPACITOR	220MF 20% 16V			IC110	BA15218N	IC		
	C 531	QETN1HM-475Z	E CAPACITOR	4.7MF 20% 50V			J 100	QND0079-001	DIN CONNECTOR		
	C 532	QETN1HM-106Z	E CAPACITOR	10MF 20% 50V			K 100	QQR0621-001Z	FERRITE BEADS		
	C 533	QETN1EM-476Z	E CAPACITOR	47MF 20% 25V			K 101	QQR0621-001Z	FERRITE BEADS		
	C 550	QETN1HM-335Z	E CAPACITOR	3.3MF 20% 50V			Q 500	KRA104M-T	D.TR.I.M		

■ Electrical parts list (SP-THA9 Main board) Block No. 06

△	Item	Parts number	Parts name	Remarks	Area
	Q 501	KRC102M-T	D.TRANSISTOR		
	Q 502	KTA1267/YG/-T	TRANSISTOR		
	Q 503	KRC102M-T	D.TRANSISTOR		
	Q 504	KTC3199/GL/-T	TRANSISTOR		
	Q 505	KRC102M-T	D.TRANSISTOR		
△	Q 506	2SD2037/EF/-T	TRANSISTOR		
△	Q 507	2SA1359/OY/	TRANSISTOR		
	Q 508	KTC3199/GL/-T	TRANSISTOR		
	Q 509	KTC3199/GL/-T	TRANSISTOR		
	Q 510	KRA102M-T	D.TRANSISTOR		
	Q 511	KTC3199/GL/-T	TRANSISTOR		
	Q 512	KTC3199/GL/-T	TRANSISTOR		
	Q 513	KRC104M-T	D.TR.I.M		
	Q 514	DTC115ESA-T	D.TR.I.M		
	Q 515	KTC3199/GL/-T	TRANSISTOR		
	Q 516	KTA1267/YG/-T	TRANSISTOR		
	Q 517	KTC3199/GL/-T	TRANSISTOR		
	Q 518	KRA111M-T	D.TR.I.M		
	Q 519	KRA111M-T	D.TR.I.M		
	Q 520	2SK105/EF/-T	TRANSISTOR(FET)		
	Q 521	2SK105/EF/-T	TRANSISTOR(FET)		
	Q 522	KTC3199/GL/-T	TRANSISTOR		
	Q 523	KRA104M-T	D.TR.I.M		
	R 100	QRE141J-102Y	C RESISTOR	1.0K 5% 1/4W	
	R 102	QRE141J-102Y	C RESISTOR	1.0K 5% 1/4W	
	R 104	QRE141J-102Y	C RESISTOR	1.0K 5% 1/4W	
	R 106	QRE141J-102Y	C RESISTOR	1.0K 5% 1/4W	
	R 108	QRE141J-102Y	C RESISTOR	1.0K 5% 1/4W	
	R 110	QRE141J-102Y	C RESISTOR	1.0K 5% 1/4W	
	R 112	QRE141J-101Y	C RESISTOR	100 5% 1/4W	
	R 113	QRE141J-100Y	C RESISTOR	10 5% 1/4W	
	R 114	QRE141J-100Y	C RESISTOR	10 5% 1/4W	
	R 115	QRE141J-100Y	C RESISTOR	10 5% 1/4W	
	R 116	QRE141J-473Y	C RESISTOR	47K 5% 1/4W	
	R 118	QRE141J-473Y	C RESISTOR	47K 5% 1/4W	
	R 119	QRE141J-100Y	C RESISTOR	10 5% 1/4W	
	R 121	QRE141J-102Y	C RESISTOR	1.0K 5% 1/4W	
	R 122	QRE141J-100Y	C RESISTOR	10 5% 1/4W	
	R 123	QRE141J-102Y	C RESISTOR	1.0K 5% 1/4W	
	R 124	QRE141J-222Y	C RESISTOR	2.2K 5% 1/4W	
	R 130	QRE141J-473Y	C RESISTOR	47K 5% 1/4W	
	R 132	QRE141J-123Y	C RESISTOR	12K 5% 1/4W	
	R 133	QRE141J-223Y	C RESISTOR	22K 5% 1/4W	
	R 134	QRE141J-223Y	C RESISTOR	22K 5% 1/4W	
	R 135	QRE141J-223Y	C RESISTOR	22K 5% 1/4W	
	R 136	QRE141J-223Y	C RESISTOR	22K 5% 1/4W	
	R 137	QRE141J-223Y	C RESISTOR	22K 5% 1/4W	
	R 138	QRE141J-223Y	C RESISTOR	22K 5% 1/4W	
	R 139	QRE141J-471Y	C RESISTOR	470 5% 1/4W	
	R 500	QRE141J-392Y	C RESISTOR	3.9K 5% 1/4W	
	R 501	QRE141J-183Y	C RESISTOR	18K 5% 1/4W	
	R 502	QRE141J-100Y	C RESISTOR	10 5% 1/4W	
	R 504	QRE141J-100Y	C RESISTOR	10 5% 1/4W	
	R 505	QRE141J-392Y	C RESISTOR	3.9K 5% 1/4W	
	R 506	QRE141J-183Y	C RESISTOR	18K 5% 1/4W	
	R 507	QRE141J-392Y	C RESISTOR	3.9K 5% 1/4W	
	R 508	QRE141J-183Y	C RESISTOR	18K 5% 1/4W	
	R 509	QRE141J-100Y	C RESISTOR	10 5% 1/4W	
	R 510	QRE141J-100Y	C RESISTOR	10 5% 1/4W	
	R 511	QRE141J-392Y	C RESISTOR	3.9K 5% 1/4W	
	R 512	QRE141J-183Y	C RESISTOR	18K 5% 1/4W	
	R 513	QRE141J-392Y	C RESISTOR	3.9K 5% 1/4W	
	R 514	QRE141J-183Y	C RESISTOR	18K 5% 1/4W	

△	Item	Parts number	Parts name	Remarks	Area
	R 515	QRE141J-100Y	C RESISTOR	10 5% 1/4W	
	R 516	QRE141J-100Y	C RESISTOR	10 5% 1/4W	
△	R 517	QRZ9005-100X	F.RES I/M	10 1/0W	
	R 518	QRE141J-102Y	C RESISTOR	1.0K 5% 1/4W	
	R 519	QRE141J-102Y	C RESISTOR	1.0K 5% 1/4W	
△	R 520	QRZ9005-100X	F.RES I/M	10 1/0W	
	R 521	QRE141J-104Y	C RESISTOR	100K 5% 1/4W	
	R 522	QRE141J-102Y	C RESISTOR	1.0K 5% 1/4W	
	R 523	QRE141J-102Y	C RESISTOR	1.0K 5% 1/4W	
	R 524	QRE141J-103Y	C RESISTOR	10K 5% 1/4W	
	R 525	QRL012J-271	UNF OMF.RES	270 5% 1/1W	
	R 526	QRE141J-122Y	C RESISTOR	1.2K 5% 1/4W	
	R 527	QRE141J-331Y	C RESISTOR	330 5% 1/4W	
	R 528	QRE141J-223Y	C RESISTOR	22K 5% 1/4W	
	R 529	QRE141J-753Y	C RESISTOR	75K 5% 1/4W	
	R 530	QRE141J-101Y	C RESISTOR	100 5% 1/4W	
	R 531	QRE141J-753Y	C RESISTOR	75K 5% 1/4W	
	R 532	QRE141J-222Y	C RESISTOR	2.2K 5% 1/4W	
	R 533	QRE141J-223Y	C RESISTOR	22K 5% 1/4W	
	R 534	QRE141J-102Y	C RESISTOR	1.0K 5% 1/4W	
	R 535	QRE141J-224Y	C RESISTOR	220K 5% 1/4W	
△	R 536	QRZ9006-4R7X	F RESISTOR	4.7 1/0W	
	R 537	QRE141J-103Y	C RESISTOR	10K 5% 1/4W	
	R 538	QRE141J-103Y	C RESISTOR	10K 5% 1/4W	
	R 539	QRE141J-223Y	C RESISTOR	22K 5% 1/4W	
	R 540	QRE141J-103Y	C RESISTOR	10K 5% 1/4W	
	R 541	QRE141J-222Y	C RESISTOR	2.2K 5% 1/4W	
	R 542	QRE141J-222Y	C RESISTOR	2.2K 5% 1/4W	
	R 543	QRE141J-103Y	C RESISTOR	10K 5% 1/4W	
	R 544	QRE141J-104Y	C RESISTOR	100K 5% 1/4W	
	R 545	QRE141J-104Y	C RESISTOR	100K 5% 1/4W	
	R 546	QRE141J-103Y	C RESISTOR	10K 5% 1/4W	
	R 547	QRE141J-104Y	C RESISTOR	100K 5% 1/4W	
	R 548	QRE141J-104Y	C RESISTOR	100K 5% 1/4W	
	R 549	QRE141J-104Y	C RESISTOR	100K 5% 1/4W	
	R 550	QRE141J-104Y	C RESISTOR	100K 5% 1/4W	
	R 551	QRE141J-104Y	C RESISTOR	100K 5% 1/4W	
	R 552	QRE141J-104Y	C RESISTOR	100K 5% 1/4W	
	R 553	QRE141J-103Y	C RESISTOR	10K 5% 1/4W	
	R 554	QRE141J-103Y	C RESISTOR	10K 5% 1/4W	
	R 555	QRE141J-103Y	C RESISTOR	10K 5% 1/4W	
	R 556	QRE141J-103Y	C RESISTOR	10K 5% 1/4W	
	R 557	QRE141J-104Y	C RESISTOR	100K 5% 1/4W	
	R 558	QRE141J-223Y	C RESISTOR	22K 5% 1/4W	
	R 559	QRE141J-104Y	C RESISTOR	100K 5% 1/4W	
	R 560	QRE141J-223Y	C RESISTOR	22K 5% 1/4W	
	R 561	QRE141J-104Y	C RESISTOR	100K 5% 1/4W	
	R 562	QRE141J-101Y	C RESISTOR	100 5% 1/4W	
	R 563	QRE141J-102Y	C RESISTOR	1.0K 5% 1/4W	
	R 564	QRE141J-104Y	C RESISTOR	100K 5% 1/4W	
	R 565	QRE141J-472Y	C RESISTOR	4.7K 5% 1/4W	
	R 566	QRE141J-472Y	C RESISTOR	4.7K 5% 1/4W	
	R 567	QRE141J-103Y	C RESISTOR	10K 5% 1/4W	
	R 568	QRE141J-103Y	C RESISTOR	10K 5% 1/4W	
	R 570	QRE141J-472Y	C RESISTOR	4.7K 5% 1/4W	
	S 100	QSW0834-001	PUSH SW		
	VR100	QVQ0021-B14	V.RES		
	Z 500	QNG0020-001Z	FUSE CLIP		
	Z 501	QNG0020-001Z	FUSE CLIP		
	Z 502	QNG0020-001Z	FUSE CLIP		
	Z 503	QNG0020-001Z	FUSE CLIP		

■ Electrical parts list (SP-THA9 Sub board) Block No. 07

△	Item	Parts number	Parts name	Remarks	Area	△	Item	Parts number	Parts name	Remarks	Area
	C 202	QETN1HM-105Z	E CAPACITOR	1.0MF 20% 50V			C 335	QFN31HJ-471Z	M.CAPA. I.M	470PF 5% 50V	
	C 203	QFVF1HJ-104Z	MF CAPACITOR	.10MF 5% 50V			C 336	QTE1H06-475Z	E CAPACITOR		
	C 204	QFVF1HJ-184Z	MF CAPACITOR	.18MF 5% 50V			C 337	QCB1HK-221Y	C CAPACITOR	220PF 10% 50V	
	C 205	QFN31HJ-393Z	M CAPACITOR	.039MF 5% 50V			C 338	QCSB1HK-3R3Y	C CAPACITOR	3.3PF 10% 50V	
	C 206	QFN31HJ-103Z	M CAPACITOR	.010MF 5% 50V			C 339	QFVF1HJ-224Z	MF CAPACITOR	.22MF 5% 50V	
	C 207	QFN31HJ-103Z	M CAPACITOR	.010MF 5% 50V			C 340	QFVF1HJ-224Z	MF CAPACITOR	.22MF 5% 50V	
	C 208	QETN1HM-475Z	E CAPACITOR	4.7MF 20% 50V			C 350	QETN1HM-226Z	E CAPACITOR	22MF 20% 50V	
	C 209	QFN31HJ-471Z	M.CAPA. I.M	470PF 5% 50V			C 351	QETN1HM-226Z	E CAPACITOR	22MF 20% 50V	
	C 210	QTE1H06-475Z	E CAPACITOR				C 352	QFN31HJ-392Z	M.CAPA. I.M	3900PF 5% 50V	
	C 211	QETN1HM-106Z	E CAPACITOR	10MF 20% 50V			C 353	QFN31HJ-392Z	M.CAPA. I.M	3900PF 5% 50V	
	C 212	QETN1HM-107Z	E CAPACITOR	100MF 20% 50V		△	C 400	QCZ9105-472	C.CAPACITOR	4700PF	
	C 213	QETN1EM-107Z	E CAPACITOR	100MF 20% 25V			C 412	QETN1HM-105Z	E CAPACITOR	1.0MF 20% 50V	
	C 214	QETN1HM-476Z	E CAPACITOR	47MF 20% 50V			CN102	QGB2510K2-06	CONNECTOR		
	C 215	QCS31HJ-3R0Z	C CAPACITOR	3.0PF 5% 50V			CN103	QGB2510K2-14	CONNECTOR		
	C 216	QETN1HM-475Z	E CAPACITOR	4.7MF 20% 50V			CN105	QGB2510K2-20	SOCKET		
	C 217	QETN1HM-475Z	E CAPACITOR	4.7MF 20% 50V			CN106	QGB2510K2-14	CONNECTOR		
	C 218	QFVF1HJ-224Z	MF CAPACITOR	.22MF 5% 50V			CN107	QGA7901C1-02	CONNECTOR		
	C 219	QFVF1HJ-224Z	MF CAPACITOR	.22MF 5% 50V			CN108	QGA7901C1-02	CONNECTOR		
	C 223	QCSB1HJ-100Y	C CAPACITOR	10PF 5% 50V			CN109	QGA3901F2-04	CONNECTOR		
	C 225	QETN2AM-226Z	E CAPA I/M	22MF 20% 100V			CN110	QGB2510K2-10	CONNECTOR		
	C 226	QFN31HJ-103Z	M CAPACITOR	.010MF 5% 50V			CN111	QGB2510K2-12	CONNECTOR		
	C 227	QFN31HJ-103Z	M CAPACITOR	.010MF 5% 50V			D 202	1SS133-T2	SI DIODE		
	C 228	QFN31HJ-103Z	M CAPACITOR	.010MF 5% 50V			D 203	1SS133-T2	SI DIODE		
	C 229	QFN31HJ-223Z	M CAPACITOR	.022MF 5% 50V			D 204	1N5402M-20	DIODE		
	C 230	QFN31HJ-223Z	M CAPACITOR	.022MF 5% 50V			D 205	MTZJ15C-T2	Z DIODE		
	C 231	QFN31HJ-103Z	M CAPACITOR	.010MF 5% 50V			D 206	MTZJ6.2B-T2	ZENER DIODE		
	C 232	QETN1HM-475Z	E CAPACITOR	4.7MF 20% 50V			D 207	1SS133-T2	SI DIODE		
	C 233	QFV61HJ-104Z	MF CAPACITOR	.10MF 5% 50V			D 208	SLR-325MG-T	LED I M		
	C 300	QFN31HJ-471Z	M.CAPA. I.M	470PF 5% 50V			D 209	SLR-325MG-T	LED I M		
	C 301	QETN1HM-225Z	E CAPACITOR	2.2MF 20% 50V			D 210	1SS133-T2	SI DIODE		
	C 302	QCB1HK-221Y	C CAPACITOR	220PF 10% 50V			D 211	1SS133-T2	SI DIODE		
	C 303	QETN1HM-226Z	E CAPACITOR	22MF 20% 50V			D 212	MTZJ6.2B-T2	ZENER DIODE		
	C 304	QETN1EM-107Z	E CAPACITOR	100MF 20% 25V			D 214	MTZJ15C-T2	Z DIODE		
	C 305	QETN1HM-106Z	E CAPACITOR	10MF 20% 50V			D 215	1N5402M-20	DIODE		
	C 306	QCSB1HK-3R3Y	C CAPACITOR	3.3PF 10% 50V			D 216	1SS133-T2	SI DIODE		
	C 307	QFVF1HJ-224Z	MF CAPACITOR	.22MF 5% 50V			D 217	MTZJ6.2B-T2	ZENER DIODE		
	C 308	QFVF1HJ-224Z	MF CAPACITOR	.22MF 5% 50V			D 218	1SS133-T2	SI DIODE		
	C 309	QETN1HM-106Z	E CAPACITOR	10MF 20% 50V			D 219	1SS133-T2	SI DIODE		
	C 310	QETN1HM-226Z	E CAPACITOR	22MF 20% 50V			D 300	1SS133-T2	SI DIODE		
	C 311	QETN1EM-107Z	E CAPACITOR	100MF 20% 25V			D 301	1SS133-T2	SI DIODE		
	C 312	QCB1HK-221Y	C CAPACITOR	220PF 10% 50V			D 302	1SS133-T2	SI DIODE		
	C 313	QETN1HM-225Z	E CAPACITOR	2.2MF 20% 50V			D 303	1SS133-T2	SI DIODE		
	C 314	QFN31HJ-471Z	M.CAPA. I.M	470PF 5% 50V			D 304	1SS133-T2	SI DIODE		
	C 315	QCSB1HK-3R3Y	C CAPACITOR	3.3PF 10% 50V			D 400	1SS133-T2	SI DIODE		
	C 316	QFVF1HJ-224Z	MF CAPACITOR	.22MF 5% 50V			D 401	1SR35-400A-T5	DIODE		
	C 317	QFVF1HJ-224Z	MF CAPACITOR	.22MF 5% 50V			IC104	BA15218N	IC		
	C 318	QFN31HJ-471Z	M.CAPA. I.M	470PF 5% 50V		△	IC105	STK404-130	IC		
	C 319	QTE1H06-475Z	E CAPACITOR			△	IC106	STK402-030	IC		
	C 320	QCB1HK-221Y	C CAPACITOR	220PF 10% 50V		△	IC107	STK402-230	IC		
	C 321	QETN1EM-107Z	E CAPACITOR	100MF 20% 25V			IC201	BA15218N	IC		
	C 322	QETN1EM-107Z	E CAPACITOR	100MF 20% 25V			IC202	BA15218N	IC		
	C 323	QCSB1HK-3R3Y	C CAPACITOR	3.3PF 10% 50V			J 101	QNB0065-002	SPK TERMINAL		
	C 324	QFVF1HJ-224Z	MF CAPACITOR	.22MF 5% 50V			J 102	QNB0070-002	SPK TERMINAL		
	C 325	QFVF1HJ-224Z	MF CAPACITOR	.22MF 5% 50V			L 200	QQLZ003-1R0	INDUCTOR		
	C 326	QETN1EM-107Z	E CAPACITOR	100MF 20% 25V			L 300	QQLZ003-1R0	INDUCTOR		
	C 327	QETN1EM-107Z	E CAPACITOR	100MF 20% 25V			L 301	QQLZ003-1R0	INDUCTOR		
	C 328	QCB1HK-221Y	C CAPACITOR	220PF 10% 50V			L 302	QQLZ003-1R0	INDUCTOR		
	C 329	QTE1H06-475Z	E CAPACITOR				L 303	QQLZ003-1R0	INDUCTOR		
	C 330	QFN31HJ-471Z	M.CAPA. I.M	470PF 5% 50V			L 304	QQLZ003-1R0	INDUCTOR		
	C 331	QETN1HM-226Z	E CAPACITOR	22MF 20% 50V			MR200	QRZ0197-R22	EMIT.RESISTOR	1/1W	
	C 332	QCSB1HK-3R3Y	C CAPACITOR	3.3PF 10% 50V			Q 202	2SA1038S/SE-T	TRANSISTOR		
	C 333	QFVF1HJ-224Z	MF CAPACITOR	.22MF 5% 50V			Q 204	2SK2937	FET		
	C 334	QFVF1HJ-224Z	MF CAPACITOR	.22MF 5% 50V			Q 205	KRA111M-T	D.TR.I.M		

■ Electrical parts list (SP-THA9 Sub board) Block No. 07

△	Item	Parts number	Parts name	Remarks	Area	△	Item	Parts number	Parts name	Remarks	Area
	Q 206	2SC2389S/SE/-T	TRANSISTOR				R 263	QRE141J-103Y	C RESISTOR	10K 5% 1/4W	
	Q 207	2SA1038S/SE/-T	TRANSISTOR				R 264	QRE141J-103Y	C RESISTOR	10K 5% 1/4W	
	Q 208	2SK2937	FET				R 265	QRE141J-223Y	C RESISTOR	22K 5% 1/4W	
	Q 209	2SC2389S/SE/-T	TRANSISTOR				R 266	QRE141J-472Y	C RESISTOR	4.7K 5% 1/4W	
	Q 210	2SK105/EF/-T	TRANSISTOR(FET)				R 267	QRE141J-103Y	C RESISTOR	10K 5% 1/4W	
	Q 211	KRC111M-T	TR I/M				R 268	QRE141J-103Y	C RESISTOR	10K 5% 1/4W	
	Q 300	KTA1267/YG/-T	TRANSISTOR				R 269	QRE141J-103Y	C RESISTOR	10K 5% 1/4W	
	Q 301	KTA1267/YG/-T	TRANSISTOR				R 270	QRE141J-103Y	C RESISTOR	10K 5% 1/4W	
	Q 302	KTA1267/YG/-T	TRANSISTOR				R 271	QRE141J-472Y	C RESISTOR	4.7K 5% 1/4W	
	Q 303	KTA1267/YG/-T	TRANSISTOR				R 272	QRE141J-472Y	C RESISTOR	4.7K 5% 1/4W	
	Q 304	KTA1267/YG/-T	TRANSISTOR				R 273	QRE141J-221Y	C RESISTOR	220 5% 1/4W	
	R 200	QRE141J-223Y	C RESISTOR	22K 5% 1/4W			R 274	QRE141J-221Y	C RESISTOR	220 5% 1/4W	
	R 201	QRE141J-473Y	C RESISTOR	47K 5% 1/4W			R 275	QRE141J-221Y	C RESISTOR	220 5% 1/4W	
	R 208	QRE141J-473Y	C RESISTOR	47K 5% 1/4W			R 276	QRE141J-223Y	C RESISTOR	22K 5% 1/4W	
	R 209	QRE141J-222Y	C RESISTOR	2.2K 5% 1/4W			R 277	QRE141J-103Y	C RESISTOR	10K 5% 1/4W	
	R 210	QRE141J-103Y	C RESISTOR	10K 5% 1/4W			R 300	QRE141J-332Y	C RESISTOR	3.3K 5% 1/4W	
	R 211	QRE141J-103Y	C RESISTOR	10K 5% 1/4W			R 301	QRE141J-563Y	C RESISTOR	56K 5% 1/4W	
	R 212	QRE141J-100Y	C RESISTOR	10 5% 1/4W			R 302	QRE141J-182Y	C RESISTOR	1.8K 5% 1/4W	
	R 213	QRE141J-100Y	C RESISTOR	10 5% 1/4W		△	R 303	QRZ9015-101X	F.RES I/M	100 1/0W	
	R 214	QRE141J-103Y	C RESISTOR	10K 5% 1/4W			R 304	QRE141J-103Y	C RESISTOR	10K 5% 1/4W	
	R 215	QRE141J-392Y	C RESISTOR	3.9K 5% 1/4W			R 305	QRT012J-R22	UNF.MF.RES.	5% 1/1W	
	R 216	QRE141J-182Y	C RESISTOR	1.8K 5% 1/4W			R 306	QRT012J-R22	UNF.MF.RES.	5% 1/1W	
	R 217	QRE141J-563Y	C RESISTOR	56K 5% 1/4W			R 307	QRE141J-563Y	C RESISTOR	56K 5% 1/4W	
△	R 218	QRZ9015-221X	F.RES I/M	220 1/0W			R 308	QRE141J-102Y	C RESISTOR	1.0K 5% 1/4W	
△	R 219	QRZ9015-221X	F.RES I/M	220 1/0W			R 309	QRE141J-153Y	C RESISTOR	15K 5% 1/4W	
	R 220	QRE141J-472Y	C RESISTOR	4.7K 5% 1/4W			R 310	QRE141J-473Y	C RESISTOR	47K 5% 1/4W	
	R 221	QRE141J-472Y	C RESISTOR	4.7K 5% 1/4W			R 311	QRK126J-4R7X	C RESISTOR	4.7 5% 1/2W	
	R 222	QRE141J-563Y	C RESISTOR	56K 5% 1/4W			R 312	QRE141J-4R7Y	C RESISTOR	4.7 5% 1/4W	
	R 223	QRE141J-102Y	C RESISTOR	1.0K 5% 1/4W			R 313	QRT012J-R22	UNF.MF.RES.	5% 1/1W	
	R 224	QRE141J-473Y	C RESISTOR	47K 5% 1/4W			R 314	QRT012J-R22	UNF.MF.RES.	5% 1/1W	
	R 225	QRE141J-153Y	C RESISTOR	15K 5% 1/4W		△	R 315	QRZ9015-101X	F.RES I/M	100 1/0W	
	R 226	QRK126J-4R7X	C RESISTOR	4.7 5% 1/2W			R 316	QRE141J-182Y	C RESISTOR	1.8K 5% 1/4W	
	R 227	QRE141J-4R7Y	C RESISTOR	4.7 5% 1/4W			R 317	QRE141J-563Y	C RESISTOR	56K 5% 1/4W	
	R 230	QRE141J-471Y	C RESISTOR	470 5% 1/4W			R 318	QRE141J-332Y	C RESISTOR	3.3K 5% 1/4W	
	R 231	QRE141J-103Y	C RESISTOR	10K 5% 1/4W			R 319	QRE141J-563Y	C RESISTOR	56K 5% 1/4W	
	R 235	QRE141J-472Y	C RESISTOR	4.7K 5% 1/4W			R 320	QRK126J-4R7X	C RESISTOR	4.7 5% 1/2W	
	R 236	QRE141J-473Y	C RESISTOR	47K 5% 1/4W			R 321	QRE141J-4R7Y	C RESISTOR	4.7 5% 1/4W	
	R 237	QRE141J-103Y	C RESISTOR	10K 5% 1/4W			R 322	QRE141J-473Y	C RESISTOR	47K 5% 1/4W	
	R 238	QRE141J-103Y	C RESISTOR	10K 5% 1/4W			R 323	QRE141J-102Y	C RESISTOR	1.0K 5% 1/4W	
	R 239	QRE141J-563Y	C RESISTOR	56K 5% 1/4W			R 324	QRE141J-153Y	C RESISTOR	15K 5% 1/4W	
	R 240	QRE141J-823Y	C RESISTOR	82K 5% 1/4W			R 325	QRE141J-332Y	C RESISTOR	3.3K 5% 1/4W	
	R 241	QRE141J-103Y	C RESISTOR	10K 5% 1/4W			R 326	QRE141J-563Y	C RESISTOR	56K 5% 1/4W	
	R 242	QRE141J-103Y	C RESISTOR	10K 5% 1/4W			R 327	QRE141J-182Y	C RESISTOR	1.8K 5% 1/4W	
	R 243	QRE141J-103Y	C RESISTOR	10K 5% 1/4W		△	R 328	QRZ9015-101X	F.RES I/M	100 1/0W	
	R 244	QRE141J-103Y	C RESISTOR	10K 5% 1/4W			R 329	QRE141J-103Y	C RESISTOR	10K 5% 1/4W	
	R 245	QRE141J-563Y	C RESISTOR	56K 5% 1/4W			R 330	QRT012J-R22	UNF.MF.RES.	5% 1/1W	
	R 246	QRE141J-823Y	C RESISTOR	82K 5% 1/4W			R 331	QRT012J-R22	UNF.MF.RES.	5% 1/1W	
	R 247	QRE141J-394Y	C RESISTOR	390K 5% 1/4W			R 332	QRE141J-563Y	C RESISTOR	56K 5% 1/4W	
	R 248	QRE141J-334Y	C RESISTOR	330K 5% 1/4W			R 333	QRE141J-102Y	C RESISTOR	1.0K 5% 1/4W	
	R 249	QRE141J-475Y	C RESISTOR	4.7M 5% 1/4W			R 334	QRE141J-153Y	C RESISTOR	15K 5% 1/4W	
	R 250	QRE141J-475Y	C RESISTOR	4.7M 5% 1/4W			R 335	QRE141J-473Y	C RESISTOR	47K 5% 1/4W	
	R 251	QRE141J-103Y	C RESISTOR	10K 5% 1/4W			R 336	QRK126J-4R7X	C RESISTOR	4.7 5% 1/2W	
	R 252	QRE141J-103Y	C RESISTOR	10K 5% 1/4W			R 337	QRE141J-4R7Y	C RESISTOR	4.7 5% 1/4W	
	R 253	QRE141J-103Y	C RESISTOR	10K 5% 1/4W			R 338	QRT012J-R22	UNF.MF.RES.	5% 1/1W	
	R 254	QRE141J-100Y	C RESISTOR	10 5% 1/4W			R 339	QRT012J-R22	UNF.MF.RES.	5% 1/1W	
	R 255	QRE141J-100Y	C RESISTOR	10 5% 1/4W		△	R 340	QRZ9015-101X	F.RES I/M	100 1/0W	
	R 256	QRE141J-472Y	C RESISTOR	4.7K 5% 1/4W			R 341	QRE141J-182Y	C RESISTOR	1.8K 5% 1/4W	
	R 257	QRE141J-332Y	C RESISTOR	3.3K 5% 1/4W			R 342	QRE141J-563Y	C RESISTOR	56K 5% 1/4W	
	R 258	QRE141J-103Y	C RESISTOR	10K 5% 1/4W			R 343	QRE141J-332Y	C RESISTOR	3.3K 5% 1/4W	
	R 259	QRE141J-104Y	C RESISTOR	100K 5% 1/4W			R 344	QRE141J-563Y	C RESISTOR	56K 5% 1/4W	
	R 260	QRE141J-473Y	C RESISTOR	47K 5% 1/4W			R 345	QRK126J-4R7X	C RESISTOR	4.7 5% 1/2W	
	R 261	QRE141J-473Y	C RESISTOR	47K 5% 1/4W			R 346	QRE141J-4R7Y	C RESISTOR	4.7 5% 1/4W	
	R 262	QRE141J-103Y	C RESISTOR	10K 5% 1/4W			R 347	QRE141J-473Y	C RESISTOR	47K 5% 1/4W	

■ Electrical parts list (SP-THA9 Sub board) Block No. 07

△	Item	Parts number	Parts name	Remarks	Area
	R 348	QRE141J-153Y	C RESISTOR	15K 5% 1/4W	
	R 349	QRE141J-102Y	C RESISTOR	1.0K 5% 1/4W	
	R 350	QRE141J-332Y	C RESISTOR	3.3K 5% 1/4W	
	R 351	QRE141J-563Y	C RESISTOR	56K 5% 1/4W	
	R 352	QRE141J-182Y	C RESISTOR	1.8K 5% 1/4W	
	R 353	QRT012J-R22	UNF.MF.RES.	5% 1/1W	
	R 354	QRT012J-R22	UNF.MF.RES.	5% 1/1W	
	R 355	QRE141J-563Y	C RESISTOR	56K 5% 1/4W	
	R 356	QRE141J-102Y	C RESISTOR	1.0K 5% 1/4W	
	R 357	QRE141J-153Y	C RESISTOR	15K 5% 1/4W	
	R 358	QRE141J-473Y	C RESISTOR	47K 5% 1/4W	
	R 359	QRK126J-4R7X	C RESISTOR	4.7 5% 1/2W	
	R 360	QRE141J-4R7Y	C RESISTOR	4.7 5% 1/4W	
	R 370	QRE141J-152Y	C RESISTOR	1.5K 5% 1/4W	
	R 371	QRE141J-152Y	C RESISTOR	1.5K 5% 1/4W	
	R 372	QRE141J-152Y	C RESISTOR	1.5K 5% 1/4W	
	R 373	QRE141J-152Y	C RESISTOR	1.5K 5% 1/4W	
	R 374	QRE141J-152Y	C RESISTOR	1.5K 5% 1/4W	
	R 375	QRE141J-222Y	C RESISTOR	2.2K 5% 1/4W	
	R 376	QRE141J-222Y	C RESISTOR	2.2K 5% 1/4W	
	R 377	QRE141J-222Y	C RESISTOR	2.2K 5% 1/4W	
	R 378	QRE141J-222Y	C RESISTOR	2.2K 5% 1/4W	
	R 379	QRE141J-222Y	C RESISTOR	2.2K 5% 1/4W	
△	RY400	QSK0055-001	RELAY		
	RY401	QSK0109-001	RELAY		
	RY402	QSK0109-001	RELAY		
	RY403	QSK0109-001	RELAY		
△	Z 400	QNG0020-001Z	FUSE CLIP		
△	Z 401	QNG0020-001Z	FUSE CLIP		

< MEMO >

Packing materials and accessories parts list

Block No.

M	4	M	M
---	---	---	---

Block No.

M	5	M	M
---	---	---	---

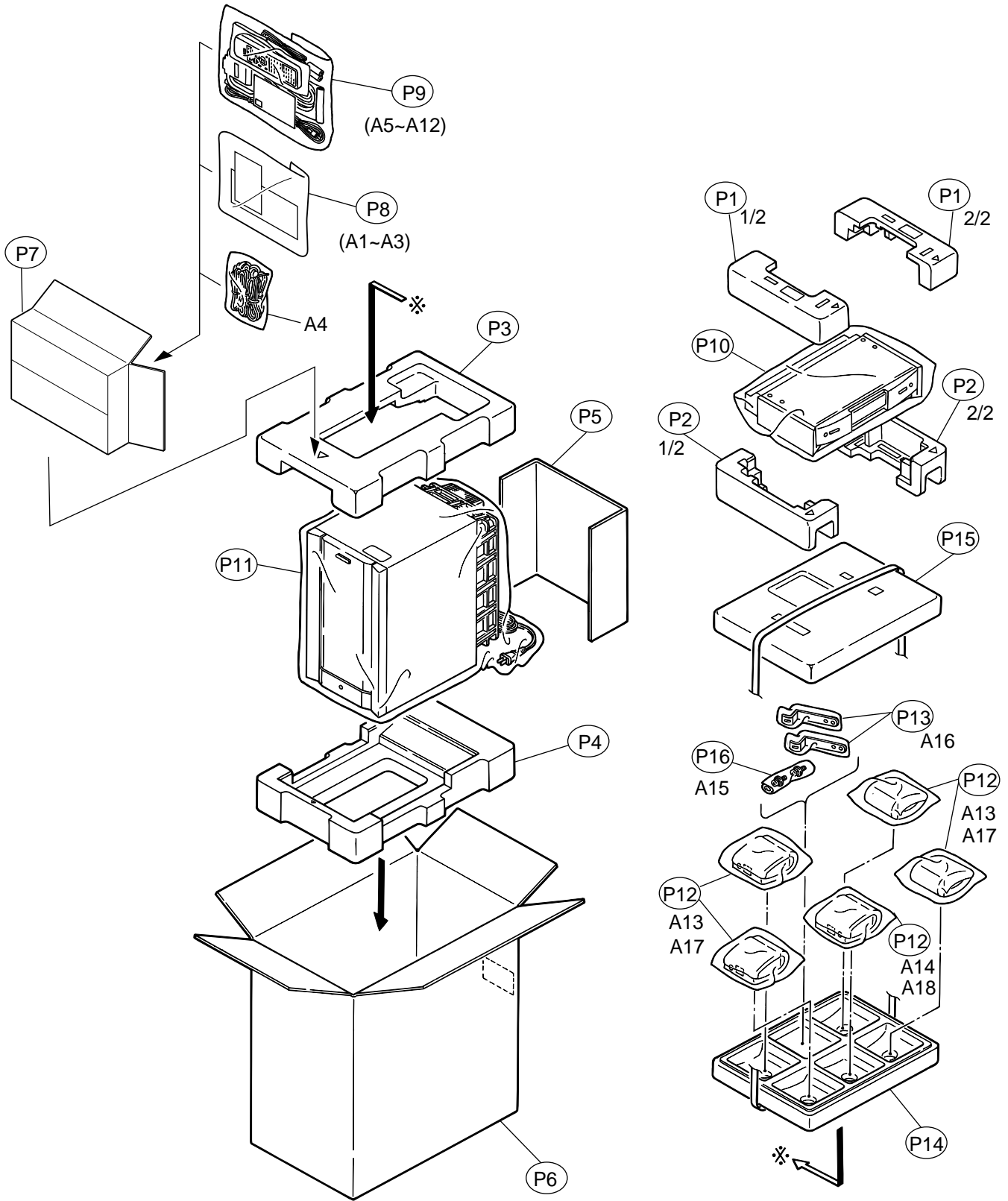

■ Parts list (Packing)

Block No. M4MM

△	Item	Parts number	Parts name	Q'ty	Description	Area
	P 1	LV20893-001A	CUSHION(TOP)	1		
	P 2	LV20894-001A	CUSHION(BOTTOM)	1		
	P 3	LV20900-001A	PACKING PAD	1		
	P 4	LV20900-002A	PACKING PAD	1		
	P 5	LV42058-001A	CARTON SHEET	1		
	P 6	LV30580-030A	PACKING CASE	1		
	P 7	LV32624-001A	ACCESSORY BOX	1		
	P 8	QPA02503505P	POLY BAG	1		
	P 9	QPA02503505P	POLY BAG	1		
	P 10	QPC05005015P	POLY BAG	1		
	P 11	QPA08009005P	POLY BAG	1		
	P 12	8500032771	PLY BAG	5	CENTER1,SATELLITE4	
	P 13	8500035701	POLY BAG	2		
	P 14	8000044311	PACKING CUSHION	1	BOTTOM	
	P 15	8000044301	PACKING CUSHION	1	TOP	
	P 16	8500035721	POLY BAG	1		

■ Parts list (Accessories)

Block No. M5MM

△	Item	Parts number	Parts name	Q'ty	Description	Area
	A 1	LVT0562-002A	INST BOOK	1	ENG	
	A 2	BT-51020-2	J=REGIST CARD	1		
	A 3	YU20333	SAFETY INST.	1		
	A 4	LV42296-002A	SPK CORD ASSY	1		
	A 5	EWP805-001W	REMOTE WIRE	1		
△	A 6	QMPE090-183-JD	POWER CORD	1		
	A 7	QAM0239-003	MINI DIN CABLE	1		
	A 8	QAM0236-001	VIDEO CABLE	1		
	A 9	EWP503-001C	ANT.WIRE	1		
	A 10	QAL0014-001	AM LOOP ANT	1		
	A 11	RM-STHA9J	REMOCON UNIT	1		
	A 12	-----	BATTERY	2		
	A 13	SP-XSA9E	SPEAKER BOX	4	SATELLITE	
	A 14	SP-XCA9E	SPEAKER BOX	1	CENTER	
	A 15	7200035911	BOLT	2		
	A 16	6400020001	BRACKET	2		
	A 17	6000181201	RATING LABEL	4		
	A 18	6000181301	RATING LABEL	1		